



# INSTALLATION INSTRUCTIONS HIGH OUTPUT 2 SPEED RAD FAN PART # 18212, 18214, 18217

Please read these instructions completely before beginning installation

## KIT CONTENTS

QTY.	DESCRIPTION	QTY.	DESCRIPTION
1	High Output RAD Fan	4	Mounting Rods
4	Rubber Isolators	4	Mounting Clips
4	Foam Pads		

## IMPORTANT

This fan assembly is designed for both PULLER and PUSHER APPLICATIONS. Note Airflow direction indicated on product label on the fan housing. (See Diagram #1)

## ELECTRIC FAN MOUNTING

This Electric Fan was designed with a unique symmetrical design, therefore when switching from a Puller to a Pusher application there is no flipping blades or reversing wires as on other reversible models. Simply mount the fan either in front or back of the radiator making sure the airflow direction arrow on the fan shroud label is pointed towards the engine.

1. Take the four supplied Rubber Isolators and install them into the four mounting hole locations on the electric fan on the radiator side. (See Diagram #2)
2. Position the Fan Assembly against the radiator or air conditioning condenser in the desired location.
3. Take the four Mounting Rods and carefully install them through the electric fan mounting holes and then through EITHER the radiator core or air conditioning condenser. (See Diagram #2)

**Caution:** Do not use excessive force when installing Mounting Rods; damage to the radiator or condenser tubes could occur. Mounting Rods should not be installed through BOTH the radiator and air conditioning condenser.

4. Take the four 1 x 1 Foam Pads & remove the paper backing. Now install them (sticky side toward the core) onto the Mounting Rods now protruding through the radiator or air conditioning condenser.
5. Take the four Mounting Clips supplied and install them onto the Mounting Rods. The Mounting Clips can only be used one time, so make sure the Fan Assembly is in the correct location.
6. Secure Mounting Clips until 1 x 1 Foam Pads are slightly compressed.
7. Cut off any excess Mounting Rod.

## Diagram #1

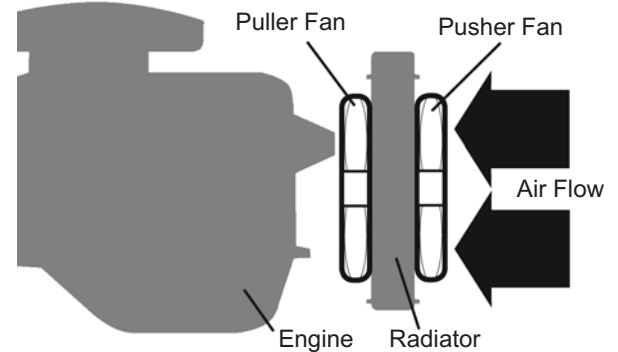

## Diagram #2

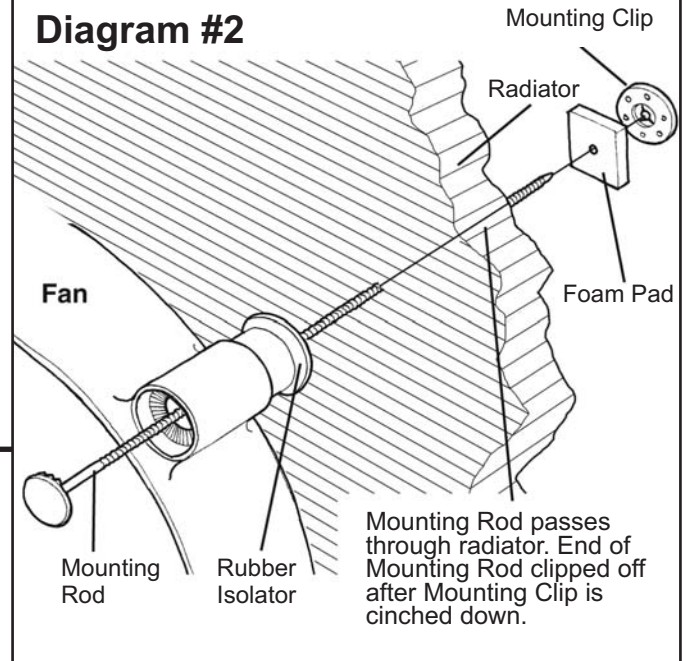

## WIRING

**Important:** The Electric Fan Assembly is built using a High Output two speed motor. If you choose to operate the fan using both speeds, two switching devices or a Dera Dual Fan Controller Part # 16788 or 16789 is recommended.

Reference Diagrams #7 & 8 on page 2

## WIRE COLOR DESIGNATIONS

**Black Wire** - Ground (-)

**Grey Wire** - Low Speed 12V positive (+)

**Brown Wire** - High Speed 12V positive (+)

## STANDARD WIRING

**Using High Speed Only** - Connect both Grey and Brown wires together to the same 12V positive (+) source

**Using Both Low and High Speeds** - Connect Grey wire to Switch #1, 12V positive (+) source.

- Connect Brown wire to Switch #2, 12V positive (+) source.

**Important:** Low speed must be activated prior to high speed activation

(Continues on Page 2)

## WIRING OPTIONS

There are a few options on how to activate (turn on) your new Electric Fan Assembly.

1. Manual Switch with Relay - Install a switch in the passenger compartment and turn on Electric Fan as desired.
2. Electric Fan Thermostat Switch
  - A. Adjustable Thermostat - Allows an adjustment range for you to determine optimal turn on temperature.
  - B. Pre Determined Temperature - Thermostat has a pre determined temp. from the factory that determines turn on temp.

We recommend activating the low speed at an earlier temperature then the high speed.  
Please visit [www.derales.com](http://www.derales.com) for available thermostat options or visit your local retailer.

**Note:** When purchasing a thermostat always consider the maximum amp draw. Some thermostats are not designed to properly handle higher amperage fans. When installing the Electric Fan with a Thermostat always follow manufacturer's instructions for specific details.

## WIRING DIAGRAM WITH RELAY (RELAY NOT SUPPLIED)

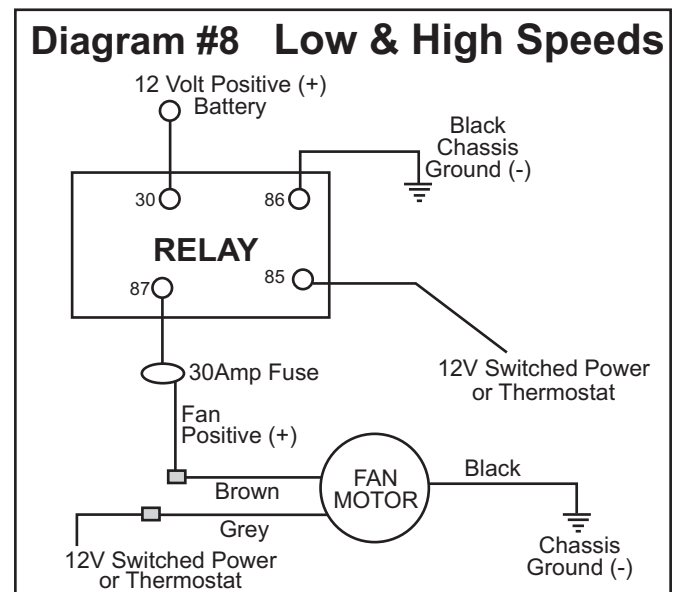
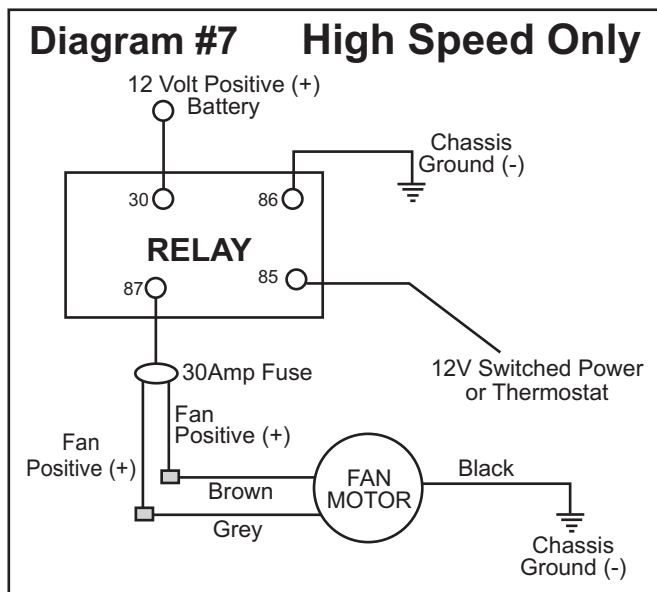

(Page 2)

**Warning:** Installation of accessories should only be undertaken by those with mechanical knowledge and are familiar with working on vehicles. Always use eye protection (goggles, safety glasses or shield). Park the vehicle in a well lit area, on level ground and apply the parking brake. Only work on a cold vehicle that has been sitting overnight, failure to do so will result in severe burns and injury. Before starting the vehicle, make sure no tools or any other items are left under hood that could interfere with or be drawn into moving parts of the engine. Failure to follow instructions can lead to severe damage and personal injury.