

- Hall Effect Technology
- Long life - extremely robust
- Aluminium or Plastic housing
- IP67 protection
- Redundant output
- Short lead times
- Form U or spring coupling drive shaft
- Programmable angles from 30° up to 360°

The new 28 mm diameter Euro-XP angle sensor is specifically aimed at arduous high-duty cycle position feedback applications in all areas of motorsports such as sequential gearbox, throttle and suspension measurement. With programmable angle selection, and a choice of U-type or spring coupling drive shafts, this compact and contactless Hall Effect sensor features IP67 sealing.



Specifications

Mechanical	
Typical Life Cycle	>50 million movements (restriction by mechanics)
Torque	< 0.8 Ncm (two O-rings)
Measuring range	360° redundant, signal 1 cw, signal 2 ccw
Max. operating speed	120 U/min
Housing	High grade temperature resistant plastic or anodised aluminium
Bearing	Bronze sleeve
Shaft	Stainless Steel - Form U or spring coupling
Environmental	
Operating temperature	-40°C to +125°C (Short term 150°C)
Vibration	5...2000 Hz; Amax = 0.75 mm; amax = 20g to IEC 60068-2-6
IP rating	IP67 (DIN EN 60529)
Electrical	
Supply Voltage	5V +/- 0.5V
Output signal	Ratiometric 5%...95% of supply (+/-25mv of specified electrical output range for both start & end voltage)
Independent linearity	+/- 0.5% of each signal range
Isolation resistance	10 MΩ (500 VDC, 1 bar, 2s)
Repeatability	<= 0.2% (dependent on mounting tolerances)
Electrical connection	See ordering code/wiring diagram

Ordering information

(Please use the characters in the chart below to construct your product code)

Sample Code: **Euro-XP - 28xx - 8xx - 214 - 911**

Series	Mechanical version	Electrical Angle	Power supply voltage Output signal Output characteristics	Electrical Connection Cable Length
Euro-XP	71 = Plastic Housing - Spring coupling 81 = Plastic Housing - U-type shaft 91 = Aluminium Housing - Spring coupling 92 = Aluminium Housing - U-type shaft	36 = Standard electrical angle 360° xx = Optional angle - from 30° to 360° in 10° steps (eg. 08 = 80°)	214 = Supply 5VDC; Ratiometric output, 5% to 95% of supply V * * +/-25mv of specified electrical output range for both start & end voltage	911 = Raychem Spec 55; XLETFE: Ø = 0.94 mm; 0.24 mm ² ; L = 500 mm

Standard options:

Euro-XP - 2871 - 836 - 214 - 911
Euro-XP - 2881 - 836 - 214 - 911
Euro-XP - 2891 - 836 - 214 - 911
Euro-XP - 2892 - 836 - 214 - 911

Custom options available on request

Dimensions in mm - Euro XP

Aluminium housing (anodised)

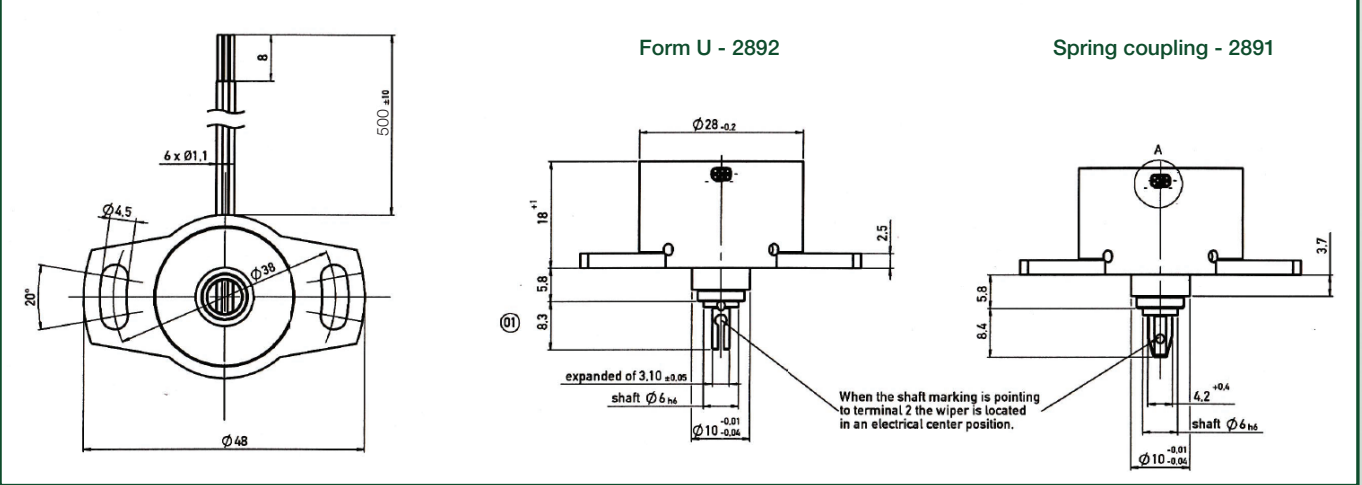

High grade plastic housing

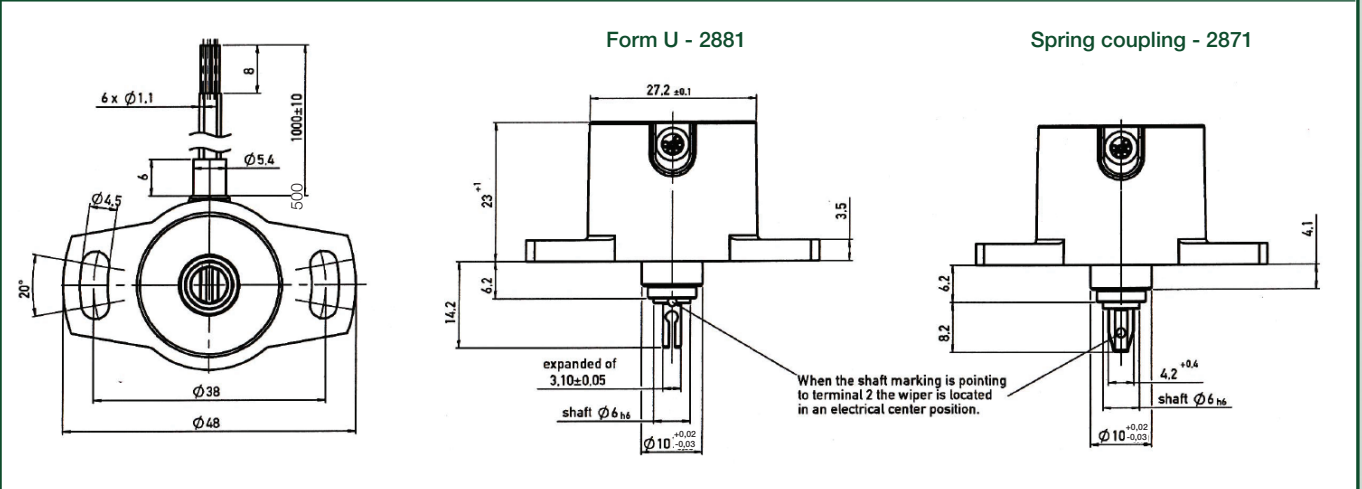

Form U and Spring coupling shaft detail for both housing types

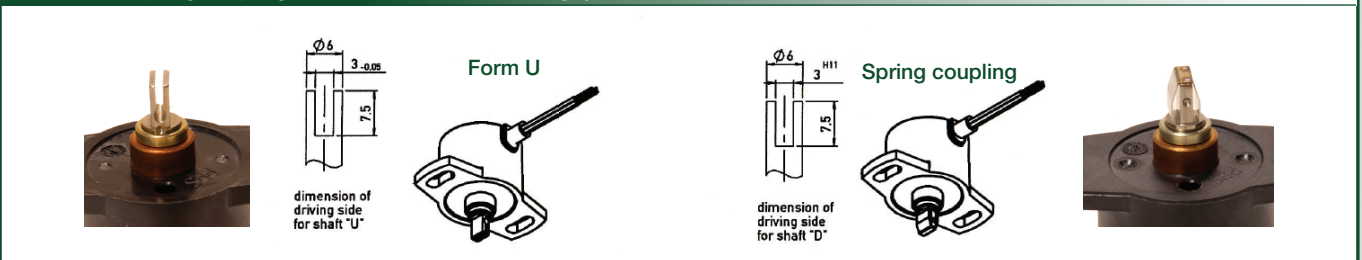

Wiring

Strain relieving VITON boot

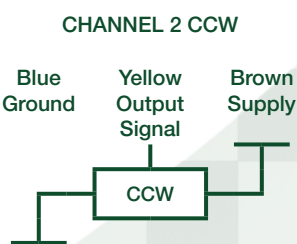
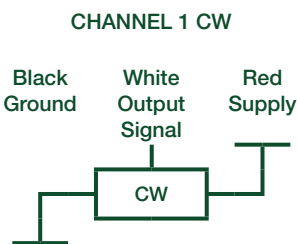

VITON Boot

