

Vehicle battery

BATTERY WARNING SYMBOLS

There is a label on the battery depicting a number of warning signs. The warning signs are as follows:



No smoking, no flames, no sparks (Red).



Shield eyes (Blue).



Keep away from children (Red).



Explosive gas (Yellow).



Battery acid (Yellow).

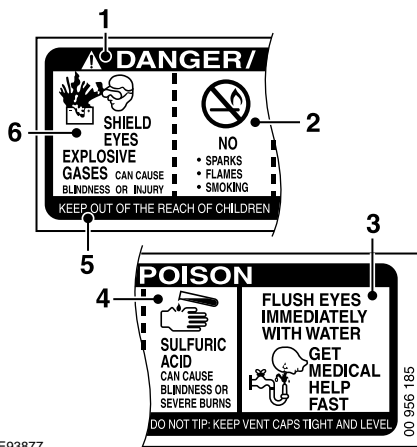

E93877

1. DANGER/POISON
2. NO
 - SPARKS
 - FLAMES
 - SMOKING
3. FLUSH EYES IMMEDIATELY
GET MEDICAL HELP FAST
4. SULFURIC ACID can cause blindness or severe burns
5. KEEP OUT OF THE REACH OF CHILDREN
DO NOT TIP
KEEP VENT CAP TIGHT AND LEVEL
6. SHIELD EYES
EXPLOSIVE GASES CAN CAUSE
BLINDNESS OR INJURY

BATTERY CARE

WARNINGS



Do not allow the battery electrolyte (fluid) to come into contact with your skin or eyes. It is both corrosive and toxic, and the resulting injuries can be severe. If any electrolyte does come into contact with your skin or eyes, immediately rinse the affected area with clean, cold water. Immediate medical advice will be required.



If battery electrolyte comes into contact with your skin and/or clothes you should remove the affected clothing and flush the skin with copious amounts of water. Seek medical assistance immediately.



If battery electrolyte comes into contact with your eyes, flush with copious amounts of clean cold water. Seek medical assistance immediately, and continue to flush with water.

Vehicle battery

WARNINGS



If swallowed, battery electrolyte can be fatal. If electrolyte is swallowed seek medical assistance immediately.



Do not connect any 12 volt equipment directly to the battery terminals. Doing so may cause a spark, which can result in an explosion.



Switch off ignition before disconnecting battery terminals. Always disconnect the earth terminal first and reconnect last.



The cell plugs and vent pipe must be in place at all times when the battery is connected to the vehicle. Ensure that the vent pipe is clear of obstructions and not kinked. Failure to do so may cause a pressure build up in the battery, resulting in an explosion.



Do not expose the battery to a naked flame or spark as the battery produces explosive, flammable gas.



Never jump start (boost) or charge, a frozen battery. Doing so can result in an explosion.



Remove all metal jewellery before working on, or near, the battery, and never allow metal tools or vehicle components to come into contact with the battery terminals. Metal objects can cause sparks, and/or short circuits, resulting in an explosion.



Do not allow the battery posts or terminals to come into contact with your skin. They contain lead, and lead compounds which are toxic. Always wash your hands thoroughly after handling the battery.

CAUTION



Do not allow battery electrolyte to come into contact with fabrics or painted surfaces. If battery electrolyte comes into contact with any surface, the surface should be washed down immediately with copious amounts of clean water. Battery electrolyte is both corrosive and toxic, and can damage a wide range of materials if left.

A low maintenance battery, specifically designed for use with this vehicle, is fitted in the luggage compartment.

In hot climates more frequent checks of the battery electrolyte level are required. If necessary, the battery cells can be topped up with distilled water.

The exterior of the battery should be occasionally wiped clean to remove any dirt or grease.

Note: Do not connect any 12 volt equipment, (for example, a 12 volt lamp), directly to the battery terminals. Use the accessory socket located in the glove box for connecting Jaguar approved accessories.

Replacement batteries

WARNING



Only fit a replacement battery of the same type and specification as the original - other batteries may vary in size or have different terminal positions which could cause a fire hazard when connected to the vehicle's electrical system.

Vehicle battery

USING BOOSTER CABLES

WARNINGS



Always wear appropriate eye protection when working with batteries.



During normal use, batteries emit explosive hydrogen gas - ensure sparks and naked lights are kept away from the luggage compartment.



Do not attempt to start the vehicle if the electrolyte in the battery is suspected of being frozen.



Make sure both batteries are of the 12 volt type and that the booster cables have insulated clamps and are approved for use with 12 volt batteries.



Do not disconnect the discharged battery.



Do not connect positive (+) terminals to negative (-) terminals, and ensure booster cables are kept away from any moving parts in the engine compartment.



Take care when working near rotating parts of the engine.

CAUTIONS



If using a boost start vehicle, under no circumstances should the vehicles come into contact with each other. This could establish an earth connection, which may cause sparks and damage.



Do not run the boost start vehicle's engine when boost starting a Jaguar vehicle. If the boost start vehicle's engine is running and the jump leads are disconnected, damage to the Jaguar vehicle's electrical system will result.

This vehicle is fitted with automatic transmission. In the event of a discharged battery preventing a normal engine start, the vehicle cannot be started by pushing or towing. Either use booster cables connected to a booster battery (e.g. on another vehicle) or fit a fully charged battery.

Using booster cables (jump leads) from a donor battery, or a battery fitted to a donor vehicle, is the only approved method of starting a vehicle with a discharged battery. This procedure differs to that used to charge a battery, which should not be attempted with the battery connected to the vehicle.

Boosting from another vehicle

WARNING



Do not use a 24 volt booster start system. These produce excessive voltage and can damage the vehicle's electrical system.

If a donor vehicle is to be used, both vehicles should be parked with their battery locations adjacent to each other. Ensure that the two vehicles do not touch.

Apply the parking brake and ensure that the transmission of both vehicles is set in neutral (**P**- Park for vehicles with automatic transmission).

Ensure that both vehicles have all electrical equipment turned off.

Where the booster cables are of a different colour, e.g. red and black, use red for positive (+). This aids identification and helps to avoid crossing positive (+) to negative (-). Take extra care to avoid crossing the polarity when using cables of the same colour.

Vehicle battery

Procedure for using booster cables

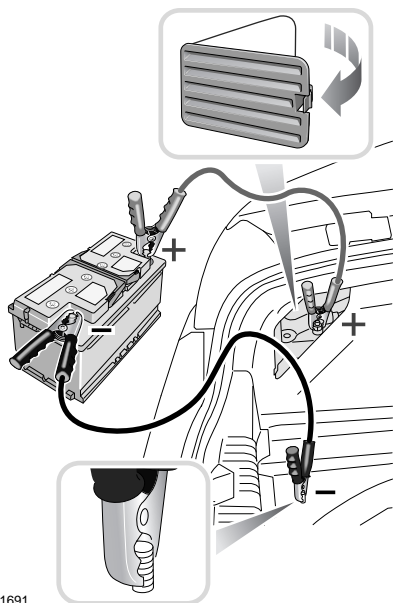

E91691

The following procedure must be followed exactly:

1. Remove the left-hand side luggage compartment trim panel cover to access the vehicle battery positive (+) remote charge terminal, remove the protective cap from the terminal.
2. Attach one end of the red jump lead to the positive (+) terminal of the booster battery and the other end to the positive (+) remote charge terminal of the vehicle battery.
3. Lift the luggage compartment floor panel to reveal the spare wheel. Remove the protective cap from the negative (-) terminal of the vehicle battery remote charge terminal.
4. Attach one end of the black jump lead to the negative (-) terminal of the booster battery and the other end to the negative (-) terminal of the vehicle battery remote charge terminal.
5. Start the disabled vehicle. Allow the engine to idle for five minutes before disconnecting the cables.
6. Disconnect the black jump lead from the negative (-) terminal of the vehicle battery remote charge terminal and the booster battery negative (-) terminal.
7. Disconnect the red jump lead from the positive (+) remote charge terminal of the vehicle and the booster battery positive (+) terminal.
8. Refit the terminal covers, trim panel and luggage compartment floor panel.

It may be necessary to reset the electric parking brake. See **ELECTRIC PARKING BRAKE (EPB)** (page 138). See **CHARGING THE VEHICLE BATTERY** (page 188).

Vehicle battery

CHARGING THE VEHICLE BATTERY

WARNINGS



Ensure that the charger used is of the correct type and rating for the battery.

Using an unsuitable charger may damage the battery, and could cause the battery to explode.



Always charge the battery in a well ventilated area away from any naked flames, sparks or other ignition sources.

During charging the battery can produce a highly explosive and flammable gas.

CAUTIONS



The battery must be disconnected and removed from the vehicle before charging. Failure to do so could result in damage to the vehicle's electrical system.



Always follow the instructions supplied with the battery charger. Failure to do so may result in damage to the battery.

Due to the restricted accessibility of the centrally located battery, charging of the battery should be assigned to qualified assistance.

If the message **BATTERY NOT CHARGING** is displayed there is either an alternator or battery fault. Turn off all electrical accessories, radio, climate control etc. Try to use minimum electrical load as possible such as power windows, convertible top etc. Seek qualified assistance as soon as possible.

Effects of battery disconnection

After the battery is reconnected:

- Reset the electric parking brake.
- Reset the electrically operated windows anti-trap function.
- The trip computer will lose all recorded trip data and all trip functions will be reset to zero. The vehicle total odometer reading is retained.
- If the battery is disconnected for more than 72 hours the radio preset channels will need to be reset.
- Reset the clock to the correct time.
- Recalibrate the seat memory positions.

The engine electronic control system automatically adapts to certain characteristics of the vehicle. When the battery is disconnected, these adaptations are lost.

On reconnection, therefore, some slightly abnormal drive symptoms may occur and the vehicle may need to be driven 16 km (10 miles) or more while the control system re-adapts.

When the battery is disconnected and then reconnected, the security system immediately returns to the state that it was before the battery was disconnected.

Note: *Ensure that the Jaguar Smart Key is available to disarm the system when reconnecting the battery. Either press the unlock button on the Smart Key or press the engine START/STOP button.*

Vehicle battery

CHANGING THE VEHICLE BATTERY

WARNINGS



Use caution when lifting the battery out of, or into, the vehicle. It is heavy and may cause injury when lifting or if dropped.



Do not tilt the battery more than 45°, as it may cause damage and may cause the electrolyte to leak out.

Battery electrolyte is highly corrosive and toxic.

CAUTIONS



Battery disconnection, removal and replacement, should only be carried out by qualified personnel. Consult your Jaguar Dealer.



If the vehicle battery is replaced by a new battery, the vehicle electrical system must be reset to the new battery by qualified personnel, to ensure maximum functionality. Consult your Jaguar Dealer.



Only a replacement battery of the same type and specification as the original should be fitted. Other batteries may vary in size or have different terminal positions, which could cause a fire hazard when connected to the vehicle's electrical system.



Do not rest the battery on any part of the vehicle, as it may cause damage due to its weight.



Do not run the engine with the battery disconnected. Doing so may damage the charging system.

Battery disposal

Used batteries should be recycled. However, batteries are hazardous - you should seek advice about disposal from a Jaguar Dealer/Authorised Repairer or your local authority.