



MODEL
2007 XK

DATE
06 June 2006

NUMBER
XK100-001

SERVICE

TECHNICAL BULLETIN

SECTION: 100-00

New PDI Instructions to Activate Passive System

AFFECTED VEHICLE RANGE:

New XK

VIN: B05215 onwards

Model Year: 2007 onwards

CONDITION SUMMARY:

ACTIVATE PASSIVE SYSTEM WITH NEW IDS PDI APPLICATION



NOTE: Edition 4 of the Pre-Delivery Instruction (PDI) Manual posted on GTR reflects enhancements made to the Integrated Diagnostic System (IDS) DVD 101 software. The software enhancements apply to all New XK models and provide new IDS functionality to activate Passive keys for vehicles beginning with VIN B05215. Edition 4 PDI Manual instructions may also be safely used on vehicles before VIN B05215.

Situation: This 'information only' bulletin has been issued to inform dealers that the Passive system has been deactivated during transport on VIN B05215 and later vehicles. Vehicles in this VIN range will only start with the smart key correctly inserted into the docking station, until the Battery Isolation Transit Relay is removed and the PDI procedures are performed.

The Passive system must be activated after the Transit Relay has been removed by completing the IDS PDI application. Vehicles with VIN B05215 and later will only start using the Passive system after the IDS PDI application has been completed.

Action: Refer to Edition 4 (or later) of the PDI Manual instructions on GTR to complete PDI using the IDS DVD 101 (or later) software. Activate the Passive system for VIN B05215 and later vehicles.

TOOLS

IDS DVD101 or later software

WARRANTY:

Information purposes only. Normal warranty policy and procedures apply.

NOTE: The information in Technical Bulletins is intended for use by trained, professional technicians with the knowledge, tools, and equipment required to do the job properly and safely. It informs these technicians of conditions that may occur on some vehicles, or provides information that could assist in proper vehicle service. The procedures should not be performed by "do-it-yourselfers." If you are not a Retailer, do not assume that a condition described affects your vehicle. Contact an authorized Jaguar service facility to determine whether the bulletin applies to a specific vehicle.



MODEL
2007 XK

DATE
20 June 2006

NUMBER
XK204-001

SERVICE

TECHNICAL BULLETIN

SECTION: 204-04

Tire Pressure Monitoring System (TPMS) Concern Diagnosis

AFFECTED VEHICLE RANGE:

New XK

VIN: B00001 onwards

Model Year: 2007 onwards

CONDITION SUMMARY:

DIAGNOSE AND RESOLVE TIRE PRESSURE WARNING MESSAGE AND LAMP ILLUMINATION

Situation: This "information only" bulletin has been published to inform dealer personnel of certain tire pressure diagnostic conditions that must be present prior to using the Integrated Diagnostic System (IDS) to diagnose a 'check tire pressure' warning message displayed in the message center

and the low tire pressure amber warning lamp  illuminated in the instrument cluster.

Action: Should a customer report a concern with a 'check tire pressure' warning message being displayed and the low tire pressure amber warning lamp being illuminated, refer to the Repair Procedure detailed in this bulletin to accurately diagnose and resolve TPMS concerns.

PARTS:

No parts required. Information purposes only.

WARRANTY:



NOTE: Tire pressure adjustments are part of proper owner maintenance. Tire pressure adjustments that are required due to a lack of owner maintenance are not to be claimed under vehicle warranty.

No warranty associated with this bulletin. This bulletin is issued for information purposes only. Normal warranty policy and procedures apply.

NOTE: The information in Technical Bulletins is intended for use by trained, professional technicians with the knowledge, tools, and equipment required to do the job properly and safely. It informs these technicians of conditions that may occur on some vehicles, or provides information that could assist in proper vehicle service. The procedures should not be performed by "do-it-yourselfers." If you are not a Retailer, do not assume that a condition described affects your vehicle. Contact an authorized Jaguar service facility to determine whether the bulletin applies to a specific vehicle.

REPAIR PROCEDURE

DIAGNOSE AND RESOLVE TIRE PRESSURE MESSAGE AND WARNING LAMP CONCERNS



CAUTION: All tires, including the spare, must be inflated to the recommended "cold tire inflation pressure" listed on the vehicle tire label.

A **full-size** spare tire (**not** a temporary-use (space saver) spare) must be inflated to the rear axle – normal pressure (if applicable). A temporary-use (space saver) spare is not fitted with a TPMS sensor.

The tire pressure gauge must be properly calibrated to ensure accurate readings.

Care should be taken when inflating tires with TPMS valves. The inflation nozzle must be aligned to the valve stem to avoid bending or damaging the TPMS valve.



NOTE: Tire pressure must be measured under the following conditions:

- At the outdoor ambient temperature (**not** while in a heated or air conditioned garage).
 - At a "cold" state (after being idle in the outdoor ambient temperature for at least one hour).
1. Verify all tires, including the spare tire, are set to the recommended tire pressures indicated on the vehicle tire label.
 2. Wait two minutes to allow the tire pressure sensors time to transmit.
 3. If the TPMS warning messages and lamp do not clear, perform the following:
 - Verify the calibration of the tire pressure gauge.
 - Ensure all tires are in a "cold" state.
 - If the above two conditions are verified, increase each tire pressure by a further 3.0 psi.
 - Wait two minutes to allow the tire pressure sensors time to transmit.
 4. If the TPMS warning messages and lamp do not clear, investigate other potential causes not addressed by this bulletin.



MODEL
2007 XK

DATE
06 June 2006

NUMBER
XK206-001

SERVICE

TECHNICAL BULLETIN

SECTION: 206-03

Front Brake Caliper Creak

AFFECTED VEHICLE RANGE:

New XK

VIN: B00001 onwards

Model Year: 2007 onwards

CONDITION SUMMARY:

CREAK FROM FRONT BRAKE CALIPER

Situation: A customer may express a concern of a creak noise emanating from the front brakes under light brake application, at slow speed, and while steering. The noise may also be heard under light or medium braking while coming to a stop with the steering wheel in a straight-ahead position. Surface contact between the caliper carrier and brake pad anchor points may be the cause.

Action: Should a customer express concern of a creak from a front brake caliper, refer to the Repair Procedure detailed in this bulletin to clean and grease the front caliper carrier and brake pad anchor surfaces.

PARTS:

C2C33568.....Grease sachet Qty 1

WARRANTY:



NOTE: Repair procedures are under constant review, and therefore times are subject to change; those quoted here must be taken as guidance only. Always refer to DDW to obtain the latest repair time.

DDW requires the use of causal part numbers. Labor only claims must show the causal part number with a quantity of zero.

<i>Description</i>	<i>SRO</i>	<i>Time (Hours)</i>	<i>Condition Code</i>	<i>Causal Part</i>
Remove front brake calipers and lubricate	70.40.02	0.5		C2C33568

Normal warranty policy and procedures apply.

NOTE: The information in Technical Bulletins is intended for use by trained, professional technicians with the knowledge, tools, and equipment required to do the job properly and safely. It informs these technicians of conditions that may occur on some vehicles, or provides information that could assist in proper vehicle service. The procedures should not be performed by "do-it-yourselfers." If you are not a Retailer, do not assume that a condition described affects your vehicle. Contact an authorized Jaguar service facility to determine whether the bulletin applies to a specific vehicle.

REPAIR PROCEDURE

CLEAN AND GREASE FRONT CALIPER BRAKE PAD ANCHOR SURFACES



NOTE: GTR lookup sequence is as follows:

GTR Home > NAS > Service Information/ X150 - XK/2007 > Workshop Manuals > New XK – Workshop Manual > Bookmark "Chassis/Brake System/206-03: Front Disc Brake" > Removal and Installation Link "Brake Pads – Vehicles With: Standard Brakes (70.40.02)"

1. Refer to Global Technical Reference (GTR) Workshop Manual section 206-03, operation 70.40.02 and remove front brake pads.
2. Clean the brake pad anchor surfaces of the caliper carrier. (Arrowed in Figure 1)
3. Grease the brake pad anchor surfaces of the caliper carrier. (Arrowed in Figure 1)
4. Refer to GTR section 206-03, operation 70.40.02 and install front brake pads.
5. Repeat steps 1-4 on the opposite side front brake caliper carrier.

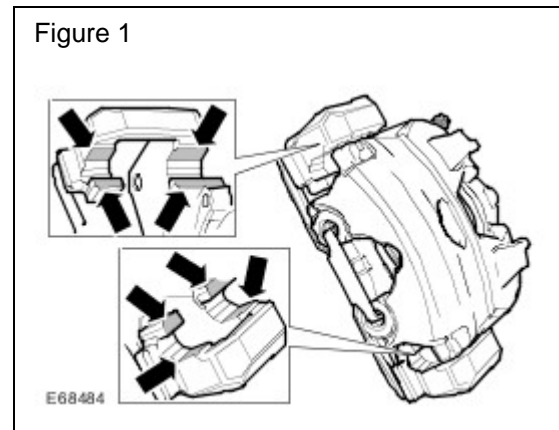



MODEL
2007 XK

DATE
03 July 2006

NUMBER
XK206-002

SERVICE

TECHNICAL BULLETIN

SECTION: 206-03

Engine Will Not Crank – 'DSC Not Available' Message Displayed

AFFECTED VEHICLE RANGE:

 **NOTE:** The listed VIN range is for situations when the Battery Isolation Transit Relay is installed (Pre-PDI). Outside of this VIN range, certain electrical conditions may cause similar 'no-crank' situations because conditions have occurred which have caused certain ABS DTCs to be stored.

New XK

VIN: B00001 to B05215

Model Year: 2007

CONDITION SUMMARY:

ENGINE WILL NOT CRANK WITH ABS DTC LOGGED - 'DSC NOT AVAILABLE' MESSAGE IS DISPLAYED ON THE MESSAGE CENTER

Situation: When investigating 'no-start' conditions where the ignition is operative, but the engine will not crank, certain Anti-lock Braking System (ABS) faults may be the cause.

When ABS Diagnostic Trouble Codes (DTCs) C0082-54 or C0044-28 are stored, the ABS module will not be able to provide the required brake pressure inputs to the Central Junction Box (CJB). These brake pressure inputs are needed to initiate the engine crank sequence. In this situation, the vehicle will not crank and the message 'DSC NOT AVAILABLE' will be displayed on the message center.

 **CAUTION:** During Pre-PDI engine starting, when the transit relay is installed, the Smart Key must be completely 'docked' into the docking station to prevent this situation from occurring.

DTCs C0082-54 or C0044-28 may be logged if the Smart Key is not completely inserted into the docking station when starting the engine when the Transit Relay is installed.

Action: Should a 'no-crank' condition occur with the 'DSC Not Available' message displayed in the message center, refer to the Repair Procedure detailed in this bulletin to calibrate the ABS pressure sensor using the Integrated Diagnostic System (IDS).

TOOLS:

IDS DVD43-Patch File 3 or DVD101 or later software.

NOTE: The information in Technical Bulletins is intended for use by trained, professional technicians with the knowledge, tools, and equipment required to do the job properly and safely. It informs these technicians of conditions that may occur on some vehicles, or provides information that could assist in proper vehicle service. The procedures should not be performed by "do-it-yourselfers." If you are not a Retailer, do not assume that a condition described affects your vehicle. Contact an authorized Jaguar service facility to determine whether the bulletin applies to a specific vehicle.

WARRANTY:



NOTE: Repair procedures are under constant review, and therefore times are subject to change; those quoted here must be taken as guidance only. Always refer to DDW to obtain the latest repair time.

DDW requires the use of causal part numbers. Labor only claims must show the causal part number with a quantity of zero.

<i>Description</i>	<i>SRO</i>	<i>Time (Hours)</i>	<i>Condition Code</i>	<i>Causal Part</i>
Calibrate ABS pressure sensor	86.93.68	0.3		C2P6022

Normal warranty policy and procedures apply.

REPAIR PROCEDURE

CALIBRATE ABS PRESSURE SENSOR



CAUTION: A Midtronics PSC-550 Vehicle Power Supply must be connected to the vehicle battery during diagnostic sessions.

This procedure requires IDS DVD43-Patch File 3 or DVD101 or later software.

1. Connect the approved battery charger/power supply to the vehicle.
2. Connect IDS diagnostic equipment to the vehicle and begin a new diagnostic session by entering the correct VIN for the current vehicle.
3. Follow the IDS prompts to read the vehicle configuration.



NOTE: Any associated diagnostic routines are to be carried out as a separate Warranty Claim.

4. Carry-out associated diagnostic routines and clear any fault codes.
5. When prompted 'Do you wish to read diagnostic trouble codes?', select 'YES' and click the  tick-box to continue.
6. When the 'Content Model' is displayed select the 'Vehicle Configuration' tab.
7. From the 'Vehicle Configuration Menu' select 'Set-up and Configuration'.
8. Select 'Anti-lock Brakes'.



NOTE: Each of the following tasks must be selected and run individually. The on-screen instructions are to be followed to complete each task in turn.

9. Select and run 'Pressure sensor calibration' application.
10. Select and run 'Lateral Accelerometer Calibration' application.
11. Select and run 'Yaw Rate Sensor Calibration' application.
12. After all tasks are completed, exit the current session.
13. Disconnect diagnostic equipment and battery charger/power supply.



Technical Service Bulletin

No.JTB00016
14 December 2006

This bulletin supersedes TSB S211-008/2006 dated 23 August, which should either be destroyed or clearly marked to show it is no longer valid (e.g. with a line across the page).

This bulletin supersedes TSB B211-004/2006 dated 23 August, which should either be destroyed or clearly marked to show it is no longer valid (e.g. with a line across the page).

This bulletin supersedes TSB XK211-001/2006 dated 23 August, which should either be destroyed or clearly marked to show it is no longer valid (e.g. with a line across the page).

Subject/Concern:	Steering Wheel Misalignment
-------------------------	-----------------------------

Models:		
S-TYPE		VIN-range: N52048 Onwards
XJ Range		VIN-range: G49701 Onwards
The New XK		VIN-range: B00379 Onwards

Markets: All

Section: 211-04

Summary:
This bulletin is to provide diagnostic clarification for steering wheel alignment during the pre-delivery inspection road test, or a customer complaint with the vehicle in low time service, with no impact damage.
This bulletin has been re-issued to update the causal part number.
The Service Instruction detailed below provides information to prevent unnecessary adjustments of the steering wheel alignment.

Labour Time:		
Operation Description	Operation No.	Time
Steering wheel - align - S-TYPE	57.60.02	0.6 hours
Steering wheel - align - XJ Range	57.60.02	0.8 hours
Steering wheel - align - New XK	57.60.02	0.7 hours

Repair/Claim Coding:	
Causal Part:	ALIGNFT
ACES Condition Code:	W6
Defect Code:	

Service Instruction

- 1 . Raise the vehicle on a suitable lift.
- 2 . Remove the vehicle undertray
- 3 . With assistance, rotate the steering wheel to align the steering column to the boss on the steering rack pinion housing.

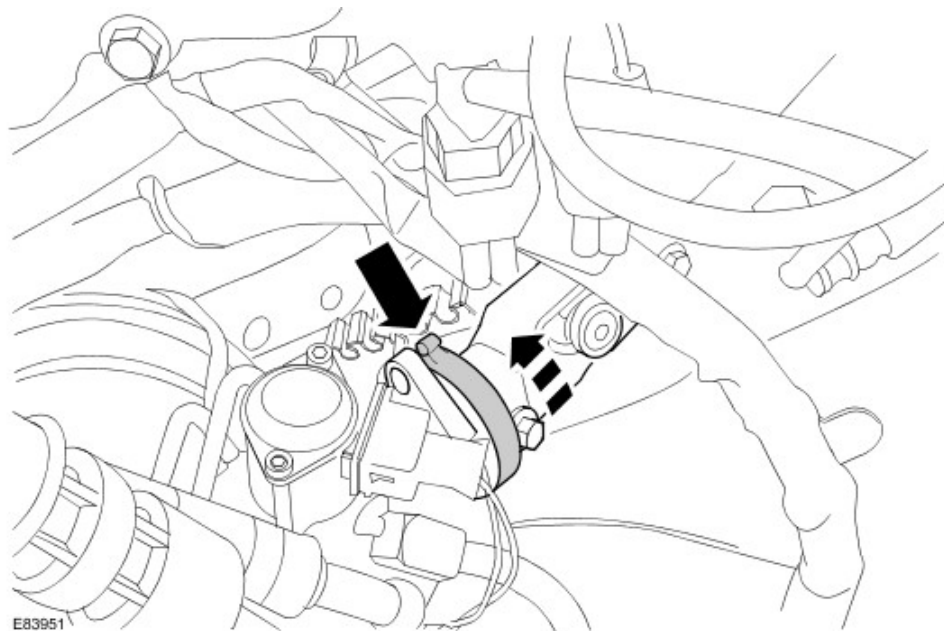

- 4 . Lower the vehicle.
- 5 . Visually check the steering wheel alignment.
- 6 . If the steering wheel alignment is less than $\pm 3^\circ$, no further action is required.
- 7 . If the steering wheel alignment is greater than $\pm 3^\circ$, photographic evidence should be provided.

8 .



WARNING: The safety precautions detailed in the Workshop Manual relating to supplementary restraint systems (SRS) must be adhered to.

Remove the airbag from the steering wheel. (see Global Technical Reference GTR Workshop Manual, section: 211-04 (57.60.01)).

- 9 . Remove the steering wheel. For additional information, refer to Global Technical Reference (GTR) S-TYPE/XJ/XK Workshop Manual Section 501-20B, Driver Air Bag Module (76.73.39).
- 10 . Adjust the wheel for correct alignment and install the steering wheel. For additional information, refer to Global Technical Reference (GTR) S-TYPE/XJ/XK Workshop Manual Section 501-20B, Driver Air Bag Module (76.73.39).
- 11 . Install the airbag (see Global Technical Reference GTR Workshop Manual, section: 211-04 (57.60.01)).
- 12 . Raise the vehicle.
- 13 . Install the undertray.
- 14 . **NOTE:** If the steering wheel is straight and level, reset the front individual toe to specification relative to the rear axle thrust line whilst maintaining the straight steering wheel position (Four wheel alignment). Please provide geometry machine print outs for vehicle geometry before and after adjustment. Test drive the vehicle to check for straight and level wheel.

Road test the vehicle to confirm the steering wheel alignment is within the $\pm 3^\circ$ limit.

- 15 . **NOTE:** Any other repairs are to be carried out as a separate Warranty Claim.

Raise an electronic product quality report (EPQR) providing photographic evidence of the alignment mark error where possible and details of the extent of steering wheel misalignment corrected, quoting the degree matching the closest to the misalignment shown in E83952.

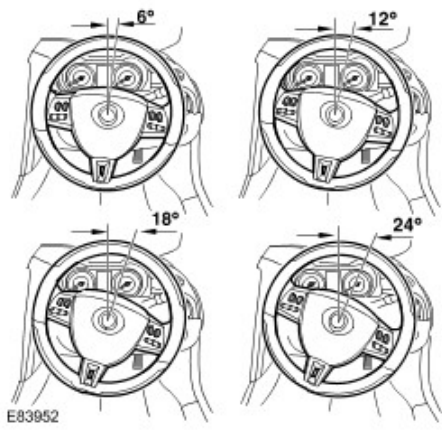

E83952

© 2006 Jaguar

Reissue

Please replace the previous edition of this bulletin.

This bulletin supersedes TSB JTB00010/2006 dated 28 November, which should either be destroyed or clearly marked to show it is no longer valid (e.g. with a line across the page).

Subject/Concern: Permanent 'High Spot' Marking To Tire Inboard Sidewall

Models:

XF		VIN-range: R00001 Onwards
X-TYPE		VIN-range: D50533 Onwards
S-TYPE		VIN-range: M96903 Onwards
XJ Range		VIN-range: G14559 Onwards
XK Range		VIN-range: A37220 Onwards
The New XK		VIN-range: B00379 Onwards

Markets: All

Section: 204-04

Summary:

This bulletin is to inform Authorized Repairers of a permanent 'high spot' marking to the tire inboard sidewall.

This version has been issued to include XF.

From the above VINs a 'red' paint dot for XF vehicles, and a 'yellow' paint dot for all other models (10-13mm in diameter) is being applied to the tire inboard sidewall to identify the high spot for radial force variation. Engineering evaluation tests have established that when installing a wheel to the hub the position of this yellow spot can influence the vehicles level of refinement. The optimum condition is to bias the wheel on the hub spigot towards the tires red/yellow dot position. To achieve this optimum condition the following process should be adhered to when installing a wheel to the vehicle. Follow the Service Instruction outlined below.

Service Instruction

Installation of Wheels and Tires

- To ensure that the optimum position of the wheel to the hub is achieved, the red (XF) and yellow (all other models) spot (see E88271) must be placed in the lowest position (6 o'clock), the wheel nuts should be installed hand-tight only, and then the vehicle lowered to the ground prior to final tightening of the wheel nuts to the specified torque value.



E88271



Technical Service Bulletin

No.JTB00008v2
02 February 2007

Reissue

Please replace the previous edition of this bulletin.

This bulletin supersedes TSB JTB00008/2006 dated 28 November, which should either be destroyed or clearly marked to show it is no longer valid (e.g. with a line across the page).

Subject/Concern: Creak from Front Brake Caliper

Models:		
The New XK	Normally Aspirated	Normally Aspirated VIN-range: B00379-B15857
S-TYPE	Normally Aspirated and Diesel Only	Normally Aspirated and Diesel Only VIN-range: N52048-N80901
XJ Range	Normally Aspirated	Normally Aspirated VIN-range: G49701-H16364

Markets: All

Section: 206-03

Summary:

This bulletin addresses customer concerns of a creak noise emanating from the front brakes with light brake application, at slow speed, and manoeuvring the steering. The noise can also be heard when coming to a stop in the straight-ahead position with light or medium braking.

Version 2 of this Bulletin has been issued due to the addition of final VINs and a change in Parts Required.

Cause: Front brake caliper to brake pad anchor interface.

Action: Should a customer express concern, install new modified front brake pads. Follow the Service Instruction outlined below.

Parts Required:		
Description	Part Number	Quantity
Front brake pads	C2C 35612	1
Grease sachet	C2C 33568	1

Labour Time:		
Operation Description	Operation No.	Time
Brake noise - Service fix - New XK	70.40.02	0.5 hours
Brake noise - Service fix - S-TYPE	70.40.02	0.7 hours
Brake noise - Service fix - XJ Range	70.40.02	0.6 hours

Repair/Claim Coding:	
Causal Part:	C2C 35612
ACES Condition Code:	N/A
Defect Code:	

Service Instruction

1. Remove front brake pads (see Global Technical Reference GTR Workshop Manual, section: 206-03).
2. Clean and apply grease to the front brake caliper (see E68484).

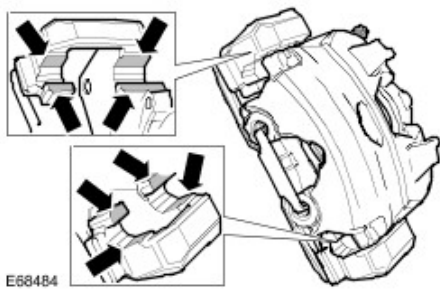

E68484

- 3 . Carry out step 2 to the opposite side front brake caliper.
- 4 . Install new front brake pads (see Global Technical Reference GTR Workshop Manual, section: 206-03).

©2007 Jaguar



Reissue

Please replace the previous edition of this bulletin.

This bulletin supersedes TSB B206-07/2005 dated 23 November, which should either be destroyed or clearly marked to show it is no longer valid (e.g. with a line across the page).

This bulletin supersedes TSB S206-08/2005 dated 23 November, which should either be destroyed or clearly marked to show it is no longer valid (e.g. with a line across the page).

Subject/Concern: Parking Brake Actuator Diagnostics

Models:		
S-TYPE		VIN-range: M45255-N91220
The New XK		VIN-range: B00379 Onwards
XJ Range		VIN-range: G00442 Onwards

Markets: All

Section: 206-05

Summary:

This bulletin has been issued for information only, to aid Authorized Repairers in diagnosing electric parking brake (EPB) actuator issues.

This version has been issued due to a change in the Model, Summary and Diagnostic Procedure.

A customer may report any of the following concerns:

NOTE: Symptoms may be permanent or intermittent.

- Electric parking brake fails to apply effectively (the parking brake may not apply at all, or the parking brake performance may be below the required standard).
- Electric parking brake fails to release properly (brake drag).
- Red brake warning lamp illuminated (constant or flashing).
- Message centre displays the message 'Parking Brake Fault' or 'Cannot Apply Parking brake'.

If further investigation reveals DTCs C1801-00 (C1801), C1802-00 (C1802) or C1803-00 (C1803) have been logged, follow the Diagnostic Procedure outlined below.

Diagnostic Procedure

This action should be taken if any of the above DTCs has been logged.

NOTE: Cable routing diagrams and useful reference photographs are shown in Appendix 1 of this bulletin.

1. From a safe vantage point underneath the vehicle, visually inspect the parking brake cable installation, parking brake caliper levers and general condition of the brakes.
 - 1 Ensure the caliper levers are returning fully to their stops.
 - 2 Confirm the cable routing is correct
 - 3 Confirm that the cable is securely fixed at all abutment points and is free to move within the C-clip.
 - 4 Where cable routing goes over the top of the stabilizer bar drop links, confirm that the stabilizer bar rubber deflector blocks are fitted, and that the brake cables have not been getting trapped behind the stabilizer bar drop links (look for tell-tale marks on the links and/or cables).

Rectify any obvious faults. If no obvious faults are found or further guidance is needed to rectify faults, please

proceed to the next stage of this bulletin. Also refer to GTR Sections 206-05 (parking Brake and Actuation) and GTR Section 206-04 (Rear Disc Brake). Take care to refer to the correct section by reference to VIN and based on whether the vehicle is fitted with high performance brakes or not.

If any faults were found and rectified, it will be necessary to re-calibrate the parking brake after rectification. See 'Parking Brake Calibration' (steps 15 to 22).

Prepare the parking brake for detailed inspection

- 2 . Ensure the vehicle battery condition is good. Additionally, in line with normal good practice, connect a battery booster pack to the vehicle whilst carrying out any diagnostic work using IDS.
- 3 . Using IDS, release the parking brake to the 'Release to Service Position'. This command can be found in the following IDS menu selection:
 - 1 Under the 'Configuration Tab' select 'Vehicle Configuration' then select 'Electronic Parking Brake' then select (for S-TYPE/XJ) 'Release to Service Position' (for XK) 'Parking Brake Unjam Procedure'.
 - 2 This should set the parking brake cables to a fully released position and so allow easy service.

- 4 .  **CAUTION: When using the special service tool, take care to operate in the 'release' direction. Actuator motor damage may result if the tool is operated in the 'apply' direction for any length of time).**

If the parking brake will not release using IDS, use the special service tool to fully release the parking brake. Refer to GTR Section 'Parking Brake Cable Tension Release' (in Section 206-05) for details of using the special service tool.

- 5 . If the parking brake will not release using IDS or the special service tool and the only DTCs logged are C1801-00 (C1801), C1802-00 (C1802) or C1803-00 (C1803) then there may be a mechanical fault with the EPB Actuator. In this case the EPB Actuator will have to be replaced.

Calipers

- 6 . Uncouple the parking brake cables from the brake calipers.
- 7 . Inspect the brake discs, pads and calipers:
 - 1 Check the discs and pads to ensure they are within the recommended wear specification. Look also for evidence of brake drag (binding brakes, signs of excessive heat build-up).
 - 2 Ensure that the parking brake lever fully returns to its stop. Rock the lever by hand. You should be able to feel it hitting a positive stop.
 - 3 Remove the brake pads (GTR Section 206-04). Ensure that the caliper pistons and slide pins are not seized.
 - 4 Using the appropriate special tool, back-off the caliper adjuster mechanism (GTR Section – Rear Brake Pads). Ensure the adjuster backs off freely.
 - 5 Reassemble the pads back into the caliper, and install the caliperback in position.
- 6 Reset the caliper adjusters by pumping the foot brake at least 10 times in the case of the integrated parking brake and service brake caliper, or by manually operating the parking brake lever in the case of the dedicated parking brake caliper, used on some of the supercharged vehicles.

Cables

- 8 . Check the parking brake cables for visible damage or kinks.
- 9 . Check the cable routing is correct. Take note of the diagrams in Appendix 1 of this Bulletin to confirm correct cable routing.
- 10 . Check that the secondary cables move freely within their outer sleeves.
- 11 . On vehicles where the cable routing goes over the top of the stabilizer bar links, confirm that the rubber deflector blocks on top of the stabilizer bar links are securely fixed and that there is no indication that the cables have been dropping down to the rear side of the stabilizer bar links.
- 12 . Check that the cable abutments are correctly located and that the abutment retaining tags are intact. When the cables are slack, it should not be possible to pull them out of the abutment brackets.
- 13 . Check that the parking brake primary C-clip is securely fixed in position and that the cable is free to slide within the C-clip. Ensure that the primary cable is not damaged where it passes through the C-clip.
- 14 . Re-connect the cables to the calipers.

Parking brake Calibration









After carrying out any work on the parking brake or rear brake calipers and discs, the parking brake should be re-calibrated as follows.

- 15 . Carry out a 30 second power reset on the EPB Module. This can be done by switching the ignition 'off' and removing the EPB Fuse (check wiring diagram in GTR to confirm which fuse to remove) or by disconnecting the battery ground cable.
- 16 . After replacing the fuse or reconnecting the battery, start the engine.
- 17 . Confirm that the message 'NOT CALIBRATED' or 'APPLY FOOT AND PARKING BRAKE' is displayed on the instrument cluster message centre. This indicates that the parking brake is in calibration mode.
- 18 . Firmly apply and release the foot brake five times.
- 19 . Whilst lightly holding your foot on the brake pedal, apply the parking brake using the EPB switch.
- 20 . Release the parking brake using the switch and then release the foot brake.
- 21 . Confirm that the brake warning lamp is not illuminated on the instrument pack and that the 'NOT CALIBRATED' or 'APPLY FOOT AND PARKING BRAKE' messages are no longer displayed in the message centre.
- 22 . Apply and release the parking brake five times using the EPB switch to ensure no error is present.

If parking brake faults are still present

- 23 . If any of the 'C1800' parking brake faults re-occur after carrying out the actions detailed in this bulletin, it may be necessary to renew the EPB Actuator.

Appendix 1

- 24 . EPB Cable Routing – S-TYPE and XJ (Normally Aspirated – pre 06 Model Year) and S-TYPE, XJ and XK (06 MY onwards – all derivatives except XKR) (Plan View).

- 25 . EPB Cable Routing – S-TYPE and XJ (Normally Aspirated – pre 06 Model Year) and S-TYPE, XJ and XK (06 MY onwards – all derivatives). Primary cable routing around sub-frame (viewed from underneath).

- 26 . EPB Cable Routing – S-TYPE and XJ (Normally Aspirated – pre 06 Model Year) and S-TYPE, XJ and XK (06 MY onwards – all derivatives). Detail of cable routing over stabilizer bar deflector blocks.

- 27 . Detail of outer cable abutment. Ensure that the abutment retaining clips are intact so that the outer cable does not pull out, even when slack.

- 28 . Detail of C-clip. Ensure that the cable and clip are fixed into position and that the cable is not damaged and free to move within the clip.

- 29 . EPB Cable Routing – S-TYPE 'R' and XJR (Supercharged – pre 06 Model Year) (Plan View).

- 30 . EPB Cable Routing – S-TYPE 'R' and XJR (Supercharged – pre 06 Model Year). Primary cable routing over subframe.

- 31 . EPB Cable Routing – XKR (Supercharged – 06 Model Year onwards) (Plan View).

- 32 . EPB Cable Routing – XKR (Supercharged – 06 Model Year onwards). Primary cable routing around subframe.



Technical Service Bulletin

No. JTB00175v3
12 January 2010

Reissue

Please replace the previous edition of this bulletin.

This bulletin supersedes TSB JTB00175v2/2009 dated 26 October, which should either be destroyed or clearly marked to show it is no longer valid (e.g. with a line across the page).

Subject/Concern: Differential Replacement

Models:		
S-TYPE	Except V6 Gasoline Manual Transmission	Except V6 Gasoline Manual Transmission VIN-range: M45255-N91220
XF		VIN-range: R00001-R41865
XJ Range		VIN-range: G00001-H31470
XK Range		VIN-range: B00001-B32752

Markets: All

Section: 205-00

Summary:

The differential design has changed for service use. If the differential needs to be replaced this technical bulletin will need to be followed once only to convert the driveline system to use the new differential. If there are any future repairs required to the differential, propshaft, or half shafts it will only require the affected components to be replaced. **Suggested Customer Concern Code - N12.**

This Version has been issued for a change in the VIN Range, Parts Required and Table 1.

Cause: New process to Install a new differential design.

Action: To install a new differential, follow the Service Instruction outlined below.

NOTE: Please see Table 1 for Differential parts, Propshaft kits and OB Joint kits.

Parts Required:		
Description	Part Number	Quantity
Differential oil	C2D3653	1
Non SC brake caliper bolts XJ / S-TYPE to G49700 / N52047	C2C1247	4
Brake caliper bolts from G49701 / N52048 / all XK / all XF	C2C27237	2
SC brake caliper bolts XJ / S-TYPE to G49700 / N52047	C2C6746	4
SC brake caliper mounting bolts XJ / S-TYPE to G49700 / N52047	C2C6745	4
Brake disc retaining clip	C2C33384	2
Hub nut	C2P12731	2
Differential filler plug	C2D3648	1
Tie rod nut - XF	XR848057	1
Tie rod nut - XJ / S-TYPE and XK	XR81593	1
Lower wishbone to knuckle nut - XJ, S-TYPE and XK	XR82681	1
Lower wishbone to knuckle nut- XF	XR853342	1
Halfshaft circlip	XR811133	2
Propshaft mounting nut	C2C34448	3
Differential mounting nut -front	C2Z2224	1
Diesel Particulate Filter mounting bracket bolts - V6 Diesel Only	CC26956	4

Special Service Tools



Powertrain Assembly Jack.
HTJ1200-2



Replacer - Mounting Bolts Final Drive To Subframe.
204-477



Halfshaft splitter handle
307-443



Halfshaft splitter
307-442



Hub puller
205-491



Adaptor nuts
205-491-01



Flange remover forcing screw
204-269

Labour Time:		
Operation Description	Operation No.	Time
Rear drive Line Replacement XF	51.91.20	3.2 hours
Rear drive Line Replacement XJ - VIN Range - G41512 – H32692	51.91.20	3 hours
Rear drive Line Replacement XJ - VIN Range - G00442 – G41511	51.91.20	3.1 hours
Rear drive Line Replacement S-Type - VIN Range - N41581 – N91220	51.91.20	3 hours
Rear drive Line Replacement S-Type - VIN Range - M45255 – N41580	51.91.20	3.1 hours
Rear drive Line Replacement XK	51.91.20	3.1 hours

Repair/Claim Coding:	
Causal Part:	C2C40994
ACES Condition Code:	42
Defect Code:	

Table 1

NOTE: The propshaft kits contain the following new components that must be fitted – propshaft, left and right half shafts, snubber washer, propshaft to differential fixings (six), link washers (three), and propshaft centre bearing fixings (two)."

Vehicle	Engine	VIN Range	Differential	Propshaft kit	2 OB Joint Kits Required
XK	V8 N/A and SC	All	C2C 40995	JLM 21883	Not Required
.
XF	V8 N/A	All	C2C 40995	JLM21865	Not Required
XF	V8 SC	All	C2C 40994	JLM21865	Not Required
XF	V6 Diesel	All	C2C 40994	JLM21867	Not Required
XF	V6 Gasoline	All	C2C 40995	JLM21869	Not Required
.

S-TYPE	V6 Diesel	to N41580	C2C 40994	JLM21868	C2C6710
S-TYPE	V6 Diesel	from N41581	C2C 40994	JLM21868	Not Required
S-TYPE	V6 Gasoline Automatic	to N41580	C2C 40995	JLM21870	C2C6710
S-TYPE	V6 Gasoline Automatic	from N41581	C2C 40995	JLM21870	Not Required
S-TYPE	V8 SC	All	C2C 40993	JLM21866	Not Required
S-TYPE	V8 N/A	to N41580	C2C 40993	JLM21866	C2C6710
S-TYPE	V8 N/A	from N41581	C2C 40993	JLM21866	Not Required
.
XJ	V8 3.5L	to G41511	C2C 40994	JLM21871	C2C6710
XJ	V8 3.5L	from G41512	C2C 40994	JLM21871	Not Required
XJ	V6 Diesel	to G41511	C2C 40994	JLM21872	C2C6710
XJ	V6 Diesel	from G41512	C2C 40994	JLM21872	Not Required
XJ	V6 Gasoline	to G41511	C2C 40995	JLM21873	C2C6710
XJ	V6 Gasoline	from G41512	C2C 40995	JLM21873	Not Required
XJ	V8 SC	All	C2C 40993	JLM21871	Not Required
XJ	V8 N/A	to G41511	C2C 40993	JLM21871	C2C6710
XJ	V8 N/A	from G41512	C2C 40993	JLM21871	Not Required
XJ LWB	V6 Diesel	to G41511	C2C 40994	JLM21875	C2C6710
XJ LWB	V6 Diesel	from G41512	C2C 40994	JLM21875	Not Required
XJ LWB	V6 Gasoline	to G41511	C2C 40995	JLM21876	C2C6710
XJ LWB	V6 Gasoline	from G41512	C2C 40995	JLM21876	Not Required
XJ LWB	V8 SC	All	C2C 40993	JLM21874	Not Required
XJ LWB	4.2L V8 N/A	to G41511	C2C 40993	JLM21874	C2C6710
XJ LWB	4.2L V8 N/A	from G41512	C2C 40993	JLM21874	Not Required
XJ LWB	3.5L V8 N/A	from G41511	C2C 40994	JLM21874	C2C6710
XJ LWB	3.5L V8 N/A	from G41512	C2C 40994	JLM21874	Not Required

Service Instruction

Appendix Table

Appendix 1: XJ Range Only step 1 - 58.
Appendix 2: S-Type Only step 59 - 111.
Appendix 3: XF Only step 112 - 149.
Appendix 4: XK Range Only step 150 - 198.

Appendix 1: XJ Range Only.

- 1 . Raise and support the vehicle. Refer to GTR 100-02 Jacking and Lifting
- 2 . Remove rear wheels and tires. Refer to GTR 204-04
- 3 . Remove the exhaust system. Refer to GTR 309-00
- 4 . Remove RH brake disc. Refer to GTR 206-04 Rear Disc Brake
- 5 . Detach the RH outer tie rod.
- 6 . Detach the lower arm from the RH wheel knuckle.
- 7 . **NOTE:** Brake disc and caliper not shown for clarity.

Remove RH driveshaft securing nut.
- 8 . Using the special tools, detach the RH halfshaft.

- 9 .  **CAUTION: To avoid damage to the halfshaft constant velocity (CV) joints and boots, do not allow the CV joints to exceed 18 degrees of travel.**

NOTE: The halfshaft is retained in the axle assembly by a retaining clip.

Using the special tools, remove the RH halfshaft.

- 10 .  **CAUTION: Under no circumstances must the flexible coupling (or its fixings) be loosened or removed from the driveshaft.**

Detach the driveshaft from the differential flange.

- 11 .  **CAUTION: When supporting the axle assembly, use a suitable packing material to prevent damage to the axle assembly.**

Using the special tool HTJ1200-02, support the axle assembly.

- 12 . Remove the axle assembly front retaining bolt.
1 Remove and discard front mounting spacer.

- 13 . **NOTE:** The axle assembly rear retaining bolts do not have to be fully removed for the axle assembly to be removed, slacken the rear retaining bolts alternately until the rear axle assembly is released.

Undo but do not remove axle assembly rear retaining bolts.

- 14 .  **CAUTION: To avoid damage to the halfshaft constant velocity (CV) joints and boots, do not allow the CV joints to exceed 18 degrees of travel.**

NOTE: The halfshaft is retained in the axle assembly by a retaining clip.

Using the special tools, remove the LH halfshaft.

- 1 With assistance lower and remove axle assembly.

- 15 . **NOTE:** Brake disc and caliper not shown for clarity.

Remove driveshaft securing nut.

- 16 . **NOTE:** Brake disc and caliper not shown for clarity.

Using the special tools, detach the LH halfshaft.

- 1 Remove the LH halfshaft.

- 17 . **NOTE:** Vehicles from VIN G00442 to G41511.

Remove the outer constant velocity (CV) joint boot retaining clip.

- 1 Remove and discard the retaining clip.

- 2 Repeat operation for the other side.

18 .



CAUTION: Do not damage the bearing retainer.

NOTE: The outer CV joint is retained to the shaft by a spring clip.

Using a suitable brass drift, remove the outer CV joint.

1 Repeat operation for the other side.

19 .

Remove the retaining clip.

1 Remove and discard the retaining clip.

.

2 Repeat operation for the other side.

20 .

Install the new retaining clip.

1 Repeat operation for the other side.

21 .



CAUTION: Make sure the CV joint ball bearings do not drop out of the CV joint.

NOTE: Use a CV grease meeting Jaguar specification.

Fit the outer CV joint (Part number C2C 6710).

1 **NOTE:** Make sure grease is applied to the CV joint.

.

Fill the CV joint with 50% grease and the CV boot with 50% grease.

2 Repeat operation for the other side.

22 .

NOTE: Make sure enough air is present in the CV boot.

Install the new retaining clip.

1 Using a suitable tool, install the retaining clip.

.

2 Repeat operation for the other side.

23 .

NOTE: All Vehicles.

NOTE: Left-hand shown, right-hand similar.

Remove the splash shields.

24 .

Remove the support bracket.

25 .

Remove the driveshaft heat shield.

26 .



CAUTION: Support the driveshaft front section.

NOTE: Note the position of the driveshaft centre bearing spacers.

Remove and discard the centre drive shaft bearing securing bolts.

1 Remove and discard the driveshaft centre bearing spacers.



27 .



CAUTION: Under no circumstances must the flexible coupling (or its fixings) be loosened or removed from the driveshaft.

Detach the driveshaft from the transmission flange.



28 .



CAUTION: Do not use excessive force on the carbon can hose bracket. Failure to follow this instruction may result in damage to the vehicle.

NOTE: For Japan and NAS spec only.

Push the carbon can hose bracket (approximately 5mm to 10 mm (3/16 inch to 3/8 inch)) towards the vehicle underfloor to increase differential clearance.



Install

29 . **NOTE:** Brake disc and caliper not shown for clarity.

NOTE: Using the old wheel hub nut, tighten to 150 Nm.

Attach the LH halfshaft to the wheel knuckle .



30 .



CAUTION: When supporting the axle assembly, use a suitable packing material to prevent damage to the axle assembly.

Using special tool HTJ1200-02, support the axle assembly.

1 Lift axle assembly towards rear subframe.

31 .



CAUTION: Do not damage the axle shaft seal.



CAUTION: To avoid damage to the halfshaft CV joints and boots, do not allow the CV joints to exceed 18 degrees of travel.



CAUTION: Make sure no damage occurs to the halfshaft seal when installing the halfshaft.

NOTE: Do not fully engage the halfshaft into the axle assembly until the oil seal protector has been removed.

Install the LH halfshaft.

1 Open halfshaft oil seal protector.

2 Remove and discard centre disc.

3 Lubricate the seal and the bearing running surfaces with clean axle oil.

4 Install the halfshaft.

5 Pull oil seal protector clear of oil seal.

6 Break the halfshaft seal protector in to two pieces and remove the halfshaft seal protector.

7 Make sure the snap ring is fully engaged and retains the halfshaft.

- 32 .  **CAUTION: To avoid damage to the halfshaft CV joints and boots, do not allow the CV joints to exceed 18 degrees of travel.**



CAUTION: Make sure no damage occurs to the halfshaft seal when installing the halfshaft.

NOTE: Make sure the retaining clip is correctly seated.

Attach the LH halfshaft.

- 33 . **NOTE:** Loosely tighten the axle assembly rear retaining bolts.

Install the axle assembly.

- 34 . **NOTE:** Make sure the original axle front spacer is not installed.

Loosely install the axle assembly front retaining bolt and new mounting bush.

- 35 .  **CAUTION: When supporting the axle assembly, use a suitable packing material to prevent damage to the axle assembly.**

Remove the special tool HTJ1200-02, supporting the axle assembly.

- 36 . Install the special tool.

- 37 .  **CAUTION: Make sure the axle rear retaining bolts are tightened to the correct torque specification. Failure to follow this instruction may result in damage to the vehicle.**

Using the special tool and a torque wrench, tighten the axle rear retaining bolts.

1 Tighten to 200 Nm.

2 To make sure the axle rear retaining bolts are torqued to the correct specification, using the special tool and a torque wrench the following calculation steps must be followed. Step 1. Multiply 200 Nm by the effective length of the torque wrench (1). Step 2. Add the effective length of the special tool (2) to the effective length of the torque wrench (1). Step 3. Divide the total of step 1 by the total of step 2. Step 4. Set the torque wrench to the figure arrived at in step 3.

- 38 . Tighten to 90 Nm.

- 39 . **NOTE:** Spacers must not be fitted between the centre bearing and the body.

With assistance, install the driveshaft and secure the center bearing.

1 Install new driveshaft centre bearing securing bolts.

2 Tighten to 47 Nm.

- 40 . Attach the driveshaft to the transmission flange.

1 Tighten to 108 Nm.



- 41 . **NOTE:** Make sure the driveshaft bolts are correctly installed.

NOTE: Some differences in the illustrations may occur but the essential information is correct.

Secure the driveshaft to the rear axle drive flange.

1 Align the mark on the driveshaft with the mark on the pinion flange.

2 Fit but do not fully tighten bolts and formed washers.



- 42 . Tighten the bolts in the sequence shown to 73 Nm (33 lb.ft).



- 43 . Install the driveshaft heat shield retaining bolts.

1 Tighten to 7 Nm.



- 44 . Install the support bracket.

1 Tighten to 9 Nm.



- 45 . **NOTE:** Right-hand shown, left-hand similar.

Install the splash shields.



- 46 .  **CAUTION: Do not damage the axle shaft seal.**



CAUTION: To avoid damage to the halfshaft CV joints and boots, do not allow the CV joints to exceed 18 degrees of travel.



CAUTION: Make sure no damage occurs to the halfshaft seal when installing the halfshaft.

NOTE: Do not fully engage the halfshaft into the axle assembly until the oil seal protector has been removed.

Install the RH halfshaft.

1 Open halfshaft oil seal protector.

2 Remove and discard centre disc.

3 Lubricate the seal and the bearing running surfaces with clean axle oil.

4 Install the halfshaft.

5 Pull oil seal protector clear of oil seal.

6 Break the halfshaft seal protector in to two pieces and remove the halfshaft seal protector.

7 Make sure the snap ring is fully engaged and retains the halfshaft.



- 47 .  **CAUTION:** To avoid damage to the halfshaft CV joints and boots, do not allow the CV joints to exceed 18 degrees of travel.



CAUTION: Make sure no damage occurs to the halfshaft seal when installing the halfshaft.

NOTE: Make sure the retaining clip is correctly seated.

Attach the RH halfshaft.



- 48 .  **CAUTION:** Axle fluid should flow from the filler plug threaded hole when full. Failure to follow this instruction may result in damage to the axle.

Fill the differential case with the recommended lubricant until a thread of oil runs from the level/filler plug.

1 **NOTE:** Install a new fluid level filler plug.

Tighten to 34 Nm.

- 49 . **NOTE:** Using the old wheel hub nut, tighten to 150 Nm.

Attach the RH wheel knuckle to the halfshaft.



- 50 . Install the RH lower arm to the wheel knuckle.



- 51 . Install the RH outer tie rod retaining nut.



- 52 . Install the RH brake disc. Ref GTR 206-04 Rear Disc Brake

- 53 . Install the exhaust system. Ref GTR 309-00

- 54 . Install rear wheels and tires. Ref GTR 204-04

- 55 .  **CAUTION:** Make sure that a new nut is installed.

Remove and discard the old wheel hub nuts, install a new wheel hub nut.

1 Tighten to 300 Nm.



- 56 .  **CAUTION:** The final tightening of the rear suspension components must be carried out with the vehicle on its wheels.

Tighten the RH lower arm bolt to 150 Nm.



- 57 .  **CAUTION:** The final tightening of the rear suspension components must be carried out with the vehicle on its wheels.

Tighten the RH outer tie rod to 55 Nm.



- 58 . Using only wheel alignment equipment approved by Jaguar, check and adjust the rear wheel alignment. Ref GTR 204-00.

Appendix 2: S-Type Only.

59 . Raise and support the vehicle. Refer to GTR 100-02 Jacking and Lifting

60 . Remove rear wheels and tires. Refer to GTR 204-04

61 . Remove the exhaust system. Refer to GTR 309-00

62 . Remove RH brake disc. Refer to GTR 206-04 Rear Disc Brake

63 . Detach the RH outer tie rod.

64 . Detach the lower arm from the RH wheel knuckle.

65 . **NOTE:** Brake disc and caliper not shown for clarity.

Remove RH driveshaft securing nut.

66 . Using the special tools, detach the RH halfshaft.

67 .  **CAUTION: To avoid damage to the halfshaft constant velocity (CV) joints and boots, do not allow the CV joints to exceed 18 degrees of travel.**

NOTE: The halfshaft is retained in the axle assembly by a retaining clip.

Using the special tools, remove the RH halfshaft.

68 .  **CAUTION: Under no circumstances must the flexible coupling (or its fixings) be loosened or removed from the driveshaft.**

Detach the driveshaft from the differential flange.

69 .  **CAUTION: When supporting the axle assembly, use a suitable packing material to prevent damage to the axle assembly.**

Using the special tool HTJ1200-02, support the axle assembly.

70 . Remove the axle assembly front retaining bolt.

1 Remove and discard front mounting spacer.

.

71 . **NOTE:** The axle assembly rear retaining bolts do not have to be fully removed for the axle assembly to be removed, slacken the rear retaining bolts alternately until the rear axle assembly is released.

Undo but do not remove axle assemble rear retaining bolts.

72 .  **CAUTION: To avoid damage to the halfshaft constant velocity (CV) joints and boots, do not allow the CV joints to exceed 18 degrees of travel.**

NOTE: The halfshaft is retained in the axle assembly by a retaining clip.

Using the special tools, remove the LH halfshaft.

1 With assistance lower and remove axle assembly.

.

73 . **NOTE:** Brake disc and caliper not shown for clarity.

Remove driveshaft securing nut.



74 . **NOTE:** Brake disc and caliper not shown for clarity.

Using the special tools, detach the LH halfshaft.

1 Remove the LH halfshaft.



75 . **NOTE:** Vehicles without supercharger from VIN M45255 to N41580.

Remove the outer constant velocity (CV) joint boot retaining clip.

1 Remove and discard the retaining clip.

.

2 Repeat operation for the other side.



76 .  **CAUTION: Do not damage the bearing retainer.**

NOTE: The outer CV joint is retained to the shaft by a spring clip.

Using a suitable brass drift, remove the outer CV joint.

1 Repeat operation for the other side.

.



77 . Remove the retaining clip.

1 Remove and discard the retaining clip.

.

2 Repeat operation for the other side.



78 . Install the new retaining clip.

1 Repeat operation for the other side.

.



79 .  **CAUTION: Make sure the CV joint ball bearings do not drop out of the CV joint.**

NOTE: Use a CV grease meeting Jaguar specification.

Fit the outer CV joint (Part number C2C 6710).

1 **NOTE:** Make sure grease is applied to the CV joint.

.

Fill the CV joint with 50% grease and the CV boot with 50% grease.

2 Repeat operation for the other side.



80 . **NOTE:** Make sure enough air is present in the CV boot.

Install the new retaining clip.

1 Using a suitable tool, install the retaining clip.

.

2 Repeat operation for the other side.



81 . **NOTE:** All Vehicles.

Remove the driveshaft heat shield.

1 Remove the 4 bolts.

.

2 Remove the driveshaft heat shield.

.



82 .



CAUTION: Support the driveshaft front section.

NOTE: Note the position of the driveshaft centre bearing spacers.

Remove and discard the centre drive shaft bearing securing bolts.

1 Remove and discard the driveshaft centre bearing spacers.

.



83 .



CAUTION: Under no circumstances must the flexible coupling (or its fixings) be loosened or removed from the driveshaft.

Detach the driveshaft from the transmission flange.



84 . **NOTE:** Brake disc and caliper not shown for clarity.

NOTE: Using the old wheel hub nut, tighten to 150 Nm.

Attach the LH halfshaft to the wheel knuckle .



85 .



CAUTION: When supporting the axle assembly, use a suitable packing material to prevent damage to the axle assembly.

Using special tool HTJ1200-02, support the axle assembly.

1 Lift axle assembly towards rear subframe.

.

86 .



CAUTION: Do not damage the axle shaft seal.



CAUTION: To avoid damage to the halfshaft CV joints and boots, do not allow the CV joints to exceed 18 degrees of travel.



CAUTION: Make sure no damage occurs to the halfshaft seal when installing the halfshaft.

NOTE: Do not fully engage the halfshaft into the axle assembly until the oil seal protector has been removed.

Install the LH halfshaft.

1 Open halfshaft oil seal protector.

.

2 Remove and discard centre disc.

.

3 Lubricate the seal and the bearing running surfaces with clean axle oil.

.

4 Install the halfshaft.

.

5 Pull oil seal protector clear of oil seal.

6 Break the halfshaft seal protector in to two pieces and remove the halfshaft seal protector.

7 Make sure the snap ring is fully engaged and retains the halfshaft.



- 87 .  **CAUTION: To avoid damage to the halfshaft CV joints and boots, do not allow the CV joints to exceed 18 degrees of travel.**

 **CAUTION: Make sure no damage occurs to the halfshaft seal when installing the halfshaft.**

NOTE: Make sure the retaining clip is correctly seated.

Attach the LH halfshaft.



- 88 . **NOTE:** Loosely tighten the axle assembly rear retaining bolts.

Install the axle assembly.



- 89 . **NOTE:** Some variation in the illustration may occur but the essential information is always correct.

NOTE: Make sure the original axle front spacer is not installed.

Loosely install the axle assembly front retaining bolt and new mounting bush.



- 90 .  **CAUTION: When supporting the axle assembly, use a suitable packing material to prevent damage to the axle assembly.**

Remove the special tool HTJ1200-02, supporting the axle assembly.

- 91 . Install the special tool.



- 92 .  **CAUTION: Make sure the axle rear retaining bolts are tightened to the correct torque specification. Failure to follow this instruction may result in damage to the vehicle.**

Using the special tool and a torque wrench, tighten the axle rear retaining bolts.

1 Tighten to 200 Nm.

2 To make sure the axle rear retaining bolts are torqued to the correct specification, using the special tool and a torque wrench the following calculation steps must be followed. Step 1. Multiply 200 Nm by the effective length of the torque wrench (1). Step 2. Add the effective length of the special tool (2) to the effective length of the torque wrench (1). Step 3. Divide the total of step 1 by the total of step 2. Step 4. Set the torque wrench to the figure arrived at in step 3.



- 93 . Tighten to 90 Nm.



- 94 . **NOTE:** Spacers must not be fitted between the centre bearing and the body.

With assistance, install the driveshaft and secure the center bearing.

1 Install new driveshaft centre bearing securing bolts.

2 Tighten to 47 Nm.



- 95 . Attach the driveshaft to the transmission flange.
1 Tighten to 108 Nm.



- 96 . **NOTE:** Make sure the driveshaft bolts are correctly installed.

NOTE: Some differences in the illustrations may occur but the essential information is correct.

Secure the driveshaft to the rear axle drive flange.

- 1 Align the mark on the driveshaft with the mark on the pinion flange.
- 2 Fit but do not fully tighten bolts and formed washers.



- 97 . Tighten the bolts in the sequence shown to 73 Nm (33 lb.ft).



- 98 . Install the center heat shield.
1 Install the bolts and tighten to 10 Nm (7 lb.ft).



- 99 .  **CAUTION: Do not damage the axle shaft seal.**



CAUTION: To avoid damage to the halfshaft CV joints and boots, do not allow the CV joints to exceed 18 degrees of travel.



CAUTION: Make sure no damage occurs to the halfshaft seal when installing the halfshaft.

NOTE: Do not fully engage the halfshaft into the axle assembly until the oil seal protector has been removed.

Install the RH halfshaft.

- 1 Open halfshaft oil seal protector.
- 2 Remove and discard centre disc.
- 3 Lubricate the seal and the bearing running surfaces with clean axle oil.
- 4 Install the halfshaft.
- 5 Pull oil seal protector clear of oil seal.
- 6 Break the halfshaft seal protector in to two pieces and remove the halfshaft seal protector.
- 7 Make sure the snap ring is fully engaged and retains the halfshaft.



- 100 .  **CAUTION: To avoid damage to the halfshaft CV joints and boots, do not allow the CV joints to exceed 18 degrees of travel.**



CAUTION: Make sure no damage occurs to the halfshaft seal when installing the halfshaft.

NOTE: Make sure the retaining clip is correctly seated.

Attach the RH halfshaft.



101 .



CAUTION: Axle fluid should flow from the filler plug threaded hole when full. Failure to follow this instruction may result in damage to the axle.

Fill the differential case with the recommended lubricant until a thread of oil runs from the level/filler plug.

1 **NOTE:** Install a new fluid level filler plug.

Tighten to 34 Nm.

102 . **NOTE:** Using the old wheel hub nut, tighten to 150 Nm.

Attach the RH wheel knuckle to the halfshaft.



103 . Install the RH lower arm to the wheel knuckle.



104 . Install the RH outer tie rod retaining nut.



105 . Install the RH brake disc. Ref GTR 206-04 Rear Disc Brake

106 . Install the exhaust system. Ref GTR 309-00

107 . Install rear wheels and tires. Ref GTR 204-04

108 .



CAUTION: Make sure that a new nut is installed.

Remove and discard the old wheel hub nuts, install a new wheel hub nut.

1 Tighten to 300 Nm.



109 .



CAUTION: The final tightening of the rear suspension components must be carried out with the vehicle on its wheels.

Tighten the RH lower arm bolt to 150 Nm.



110 .



CAUTION: The final tightening of the rear suspension components must be carried out with the vehicle on its wheels.

Tighten the RH outer tie rod to 55 Nm.



111 . Using only wheel alignment equipment approved by Jaguar, check and adjust the rear wheel alignment. Ref GTR 204-00.

Appendix 3: XF Only.

112 . Raise and support the vehicle. Refer to GTR 100-02 Jacking and Lifting

113 . Remove rear wheels and tires. Refer to GTR 204-04

114 .



115 .



116 .



117 .



118 .



119 .



120 .



CAUTION: LH illustration shown, RH is similar.



121 .



CAUTION: To avoid damage to the halfshaft constant velocity (CV) joints and boots, do not allow the CV joints to exceed 18 degrees of travel.

NOTE: The halfshaft is retained in the axle assembly by a retaining clip.



122 . Remove Exhaust Ref GTR 309-00.

123 . Torque 9Nm



124 .



CAUTION: Under no circumstances must the flexible coupling (or its fixings) be loosened or removed from the driveshaft.



CAUTION: Make sure that the driveshaft is supported with suitable retaining straps.



125 .



CAUTION: Under no circumstances must the flexible coupling (or its fixings) be loosened or removed from the driveshaft.



CAUTION: Make sure that the driveshaft is supported with suitable retaining straps.



126 .



WARNING: This step requires the aid of another technician.

NOTE: Remove and discard spacers and bolts.



127 .



CAUTION: To avoid damage to the halfshaft constant velocity (CV) joints and boots, do not allow the CV joints to exceed 18 degrees of travel.

NOTE: The halfshaft is retained in the axle assembly by a retaining clip.



128 . Using the special tool, support the axle assembly.



129 . **NOTE:** Discard the axle front spacer.

Release the LH halfshaft from the axle assembly.

1 With assistance lower and remove axle assembly.



130 .



131 . **NOTE:** Installation

NOTE: Do not fully tighten the locking nut at this stage.

Attach the LH halfshaft to the wheel knuckle.



132 .



CAUTION: When supporting the axle assembly, use suitable packing material to prevent damage to the axle assembly.

Using a transmission jack, support the differential case.



133 .



CAUTION: Do not damage the axle shaft seal.



CAUTION: To avoid damage to the halfshaft constant velocity (CV) joints and boots, do not allow the CV joints to exceed 18 degrees of travel.

NOTE: Do not fully engage the halfshaft into the axle assembly until the oil seal protector has been removed.

Install the LH halfshaft.



134 .



CAUTION: Rear mounting bolts must be tightened first, failure to follow this instruction may cause damage to the vehicle.

NOTE: Make sure the original axle front spacer is not installed.

M12 torque 90 NM M14 torque 200Nm



135 . Remove the transmission jack.



136 .



CAUTION: Do not damage the axle shaft seal.



CAUTION: To avoid damage to the halfshaft constant velocity (CV) joints and boots, do not allow the CV joints to exceed 18 degrees of travel.

NOTE: Do not fully engage the halfshaft into the axle assembly until the oil seal protector has been removed.

Install the RH halfshaft.



137 . **NOTE:** Do not fully tighten the locking nut at this stage.



138 .  **CAUTION:** Only use lubricants meeting the Jaguar specification.



CAUTION: Axle fluid should flow from the filler plug threaded hole when full. Failure to follow this instruction may result in damage to the axle.

NOTE: Install a new fluid level filler plug.

Fill the differential case with the recommended lubricant until a thread of oil runs from the level/filler plug. Tighten the level/filler plug to 34Nm.



139 .  **WARNING:** This step requires the aid of another technician.

Tighten to 47Nm.



140 .  **CAUTION:** Under no circumstances must the flexible coupling (or its fixings) be loosened or removed from the driveshaft.



CAUTION: Make sure that the driveshaft is supported with suitable retaining straps.

Tighten to 108Nm.



141 .  **CAUTION:** Tighten the bolts in the sequence shown.

Align the mark on the driveshaft with the mark on the pinion flange. Tighten bolts to 75Nm.



142 . Tighten to 9Nm.



143 . Install Exhaust system GTR reference 309-00

144 .  **CAUTION:** The final tightening of the suspension components must be carried out with the vehicle on its wheels.

Tighten to 150Nm.



145 .  **CAUTION:** The final tightening of the suspension components must be carried out with the vehicle on its wheels.

Tighten to 55Nm.



146 . Tighten to 134Nm.



147 . Install the wheel and tire ref GTR procedure 204-04.

148 .  **CAUTION:** Make sure that a new nut is installed.

Tighten to 300Nm.



- 149 . Using only wheel alignment equipment approved by Jaguar, check and adjust the rear wheel alignment Ref GTR procedure 204-00.

Appendix 4: XK Range Only.



CAUTION: Angularly Adjusted Roller (AAR) joints, used at the inboard end of some halfshafts have no internal retaining mechanism and can separate.



CAUTION: Do not allow halfshafts to hang unsupported at one end or joint damage will occur.

150 .



WARNING: Do not work on or under a vehicle supported only by a jack. Always support the vehicle on safety stands.

Raise and support the vehicle.

- 151 . Remove the rear wheels and tires.

- 152 . With assistance, remove the halfshaft retaining nuts, and retain it for the install procedure.



- 153 . Release the RH rear brake caliper.

1 Remove and discard the 2 bolts.

.

2 Tie the brake caliper aside.



- 154 . Remove the RH rear brake disc.

1 Remove the 2 clips.

.



- 155 . Remove the rear wheel trims.



- 156 . RH rear: Disconnect the toe link.

1 Remove the bolt and discard the nut.

.



- 157 . Release the RH rear lower arm.

1 Remove the bolt and discard the nut.

.



- 158 . Using the special tools, release the RH halfshaft from the drive flange.



- 159 . Using the special tools, remove the RH halfshaft.



- 160 . Remove the exhaust system Ref GTR procedure 309-00.

- 161 . With assistance: Remove the body K-frame.

1 Using a jack, support the differential.

.

2 Remove the 8 bolts.

.

3 Remove the 4 Torx bolts.



162 . Install the 2 subframe mounting bolts and remove the jack.



163 .  **CAUTION: Under no circumstances must the flexible coupling (or it's fixings) be loosened or removed from the driveshaft.**

Release the driveshaft from the rear axle drive flange.

1 Remove the 3 nuts and bolts.



164 .  **CAUTION: When supporting the axle assembly, use a suitable packing material to prevent damage to the axle assembly.**

Using a transmission jack, support the differential.

165 . Remove the axle assembly front retaining bolt.

1 Remove and discard front mounting spacer.



166 . **NOTE:** The axle assembly rear retaining bolts do not have to be fully removed for the axle assembly to be removed, slacken the rear retaining bolts alternately until the rear axle assembly is released.

Undo but do not remove axle assembly rear retaining bolts.



167 .  **CAUTION: To avoid damage to the halfshaft constant velocity (CV) joints and boots, do not allow the CV joints to exceed 18 degrees of travel.**

NOTE: The halfshaft is retained in the axle assembly by a retaining clip.

Using the special tools, remove the LH halfshaft.

1 With assistance lower and remove axle assembly.



168 . Using the special tools, release the LH halfshaft from the drive flange.
1 Remove the LH halfshaft.



169 . Remove the center heat shield.
1 Remove the 4 bolts.



170 .  **CAUTION: Under no circumstances must the flexible coupling (or it's fixings) be loosened or removed from the driveshaft.**

Release the driveshaft from the transmission drive flange.

1 Remove the 3 nuts and bolts.



171 . **NOTE:** Spacers are fitted between the centre bearing and the body.

With assistance, remove the driveshaft.

1 Remove and discard the 2 driveshaft center bearing mount bolts.

.

2 Remove and discard the driveshaft centre bearing spacers

.



172 .



CAUTION: Do not use excessive force on the carbon can hose bracket. Failure to follow this instruction may result in damage to the vehicle.

NOTE: For Japan and NAS spec only.

Push the carbon can hose bracket (approximately 5mm to 10 mm (3/16 inch to 3/8 inch)) towards the vehicle underfloor to increase differential clearance.



Install

173 . **NOTE:** Spacers must not be fitted between the centre bearing and the body.

With assistance, install the driveshaft and secure the center bearing.

1 Install new driveshaft centre bearing securing bolts.

.

2 Tighten to 47 Nm.

.



174 . Attach the driveshaft to the transmission flange.

1 Tighten the nuts and bolts to 110 Nm (81 lb.ft).

.



175 . Install the center heat shield.

1 Install the bolts and tighten to 10 Nm (7 lb.ft).

.



176 . Attach the LH halfshaft to the wheel knuckle.

1 Lightly tighten the old nut.

.



177 . Using a transmission jack, support the differential case.

1 Open the halfshaft oil seal protector.

.

2 Remove and discard the centre disc.

.

3 Lubricate the seal and the bearing running surfaces with clean axle oil.

.

4 Install the halfshaft.

.

5 Pull the oil seal protector clear of the oil seal.

.

6 Break the halfshaft seal protector in to two pieces, by using the pull ring as shown, and remove the halfshaft seal protector.

.

7 Make sure the snap ring is fully engaged and retains the halfshaft.

.



178 .



CAUTION: To avoid damage to the halfshaft CV joints and boots, do not allow the CV joints to exceed 18 degrees of travel.



CAUTION: Make sure no damage occurs to the halfshaft seal when installing the halfshaft.

NOTE: Make sure the retaining clip is correctly seated.

Attach the LH halfshaft.



179 . **NOTE:** Align to the position noted on removal.

Install the rear differential.

1 Tighten the 14mm bolt to 163 Nm (120 lb.ft).



180 . **NOTE:** Make sure the original axle front spacer is not installed.

Install the rear differential.

1 Tighten the 12mm bolt to 90Nm (66 lb.ft).



181 .  **CAUTION:** When supporting the axle assembly, use a suitable packing material to prevent damage to the axle assembly.

Remove the special tool HTJ1200-02, supporting the axle assembly.

182 . **NOTE:** Make sure the driveshaft bolts are correctly installed.

NOTE: Some differences in the illustrations may occur but the essential information is correct.

Secure the driveshaft to the rear axle drive flange.

1 Align the mark on the driveshaft with the mark on the pinion flange.

2 Fit but do not fully tighten bolts and formed washers.



183 . Tighten the bolts in the sequence shown to 73 Nm (33 lb.ft).



184 . With assistance, install the K-frame.

1 Remove the 2 bolts.

2 Tighten the M10 bolts to 40 Nm (30 lb.ft).

3 Tighten the M12 bolts to 133 Nm (98 lb.ft).

4 Tighten the sub frame bolts to 60 Nm (44 lb.ft), then a further 240 degrees.



185 . Remove the transmission jack.

186 . Install the exhaust system refer to GTR 309-00.

187 .  **CAUTION:** Do not damage the axle shaft seal.



CAUTION: To avoid damage to the halfshaft constant velocity (CV) joints and boots, do not allow the CV joints to exceed 18 degrees of travel.



CAUTION: Make sure no damage occurs to the halfshaft seal when installing the halfshaft.

NOTE: Do not fully engage the halfshaft into the axle assembly.

Install the RH halfshaft.

1 Open the halfshaft oil seal protector.

.

2 Remove and discard the centre disc.

.

3 Lubricate the seal and the bearing running surfaces with clean axle oil.

.

4 Install the halfshaft.

.

5 Pull the oil seal protector clear of the oil seal.

.

6 Break the halfshaft seal protector in to two pieces, by using the pull ring as shown, and remove the halfshaft seal protector.

7 Make sure the snap ring is fully engaged and retains the halfshaft.

.



188 . **NOTE:** Do not fully tighten the locking nut at this stage.

Attach the RH halfshaft to the wheel knuckle.

1 Lightly tighten the old nut.

.



189 . **CAUTION:** Axle fluid should flow from the filler plug threaded hole when full. Failure to follow this instruction may result in damage to the axle.

Fill the differential case with the recommended lubricant until a thread of oil runs from the level/filler plug.

1 **NOTE:** Install a new fluid level filler plug.

.

Tighten to 34 Nm.

190 . **CAUTION:** The final tightening of the suspension components must be carried out with the vehicle on its wheels.

Install the lower arm nut and bolt.

1 Tighten the nut and bolt to 150 Nm (110 lb.ft).

.



191 . **CAUTION:** The final tightening of the suspension components must be carried out with the vehicle on its wheels.

Connect the toe link.

1 Tighten the nut and bolt to 55 Nm (40 lb.ft).

.



192 . Install the RH rear brake disc.

1 Secure the clips.

.

193 . Install the RH brake caliper.

1 Tighten the bolts to 103 Nm (76 lb.ft).

.

194 . Install the rear wheels and tires.

195 . Lower the vehicle.

196 . Remove the old halfshaft nuts and install the new ones, tighten to 300 Nm (222 lb.ft).

1 Install the wheel trims.

.

197 . Install the wheel trim.

198 . Using only wheel alignment equipment approved by Jaguar, check and adjust the rear wheel alignment
Ref GTR procedure 204-00.

©2010 Jaguar

Subject/Concern:	Click, Squeak or Squeal Audible During Light Brake Application
-------------------------	--

Models:

S-TYPE	Naturally Aspirated (N/A) Only	Naturally Aspirated (N/A) Only VIN-range: N52048-N91220
XJ Range	N/A Only	N/A Only VIN-range: G49701-H25553
XK Range	N/A Only	N/A Only VIN-range: B00379-B25238

Markets: All

Section: 206-03

Summary:

Front brake pad click, squeak or squeal audible during light brake application.

Cause: Vibrations at the pad disc interface are amplified through the braking/suspension system resulting in a 1.6kHz noise audible to the driver/passenger of the vehicle. **Suggested Customer Concern Code - N17.**

Action: Should a customer express concern, follow the Service Instruction outlined below.

Parts Required:

Description	Part Number	Quantity
Front brake pad kit	C2C 39929	1
Molycote grease	C2C 39930	1

Labour Time:

Operation Description	Operation No.	Time
Front brake pad modification - S-TYPE	70.40.02	0.7 hours
Front brake pad modification - XJ Range	70.40.02	0.6 hours
Front brake pad modification - XK Range	70.40.02	0.5 hours

Repair/Claim Coding:

Causal Part:	C2C39929
ACES Condition Code:	42
Defect Code:	

Service Instruction

1. Remove front brake pads (see Global Technical Reference GTR Workshop Manual, section: 206-03).

2.  **CAUTION: Ensure an even liberal coating of grease (best applied with a small brush). Avoid contamination of brake linings, callipers and piston dust boot/seals.**

Clean and grease (C2C 39930) both brake calipers in the area shown in E104180 only.



3.  **CAUTION: Ensure an even liberal coating of grease (best applied with a small brush). Avoid contamination of brake linings, callipers and piston dust boot/seals.**

Clean and grease (C2C 39930) the piston contact area of the inboard pad brake pads, and the calliper to pad contact points of the hammer head of both inboard and outboard pads both ends (in the areas shown in E104181 only).



4 . Install front brake pads (see Global Technical Reference GTR Workshop Manual, section: 206-03).

©2008 Jaguar

SERVICE

TECHNICAL BULLETIN

Oil Cooler Feed Pipe/Hose Failure –
Inspect/Replace Hose –
Service Action S846

MODEL 2004-05 MY
XK Range

VIN A39699-A41740

Remove and destroy Bulletin 303-S846, dated 10/04.
Replace with this Bulletin.
Revisions are marked with a bar and in **bold text**.

Issue:

A concern has been identified on a number of 2004-05 MY XK Range vehicles within the above VIN range. A failure can occur at the outer crimp face of the oil cooler feed pipe/hose that leads from the engine to the intermediate connector. The same problem can occur on the oil cooler return pipe/hose leading from the intermediate joint back to the engine. These conditions can result in the possibility of engine oil loss and reduced engine performance.

Action:

Inspect, at the first available opportunity, all 2004-05 MY XK range vehicle within the above VIN range. Check the feed hose/pipe leading from the engine to the intermediate connector and the oil cooler return pipe/hose from the intermediate connector back to the engine for a date code of **43 03**.

If the date code is illegible, not present, or reads **43 03** on either the engine to intermediate connector oil cooler feed pipe/hose or the oil cooler return pipe/hose, both pipe/hoses must be replaced.

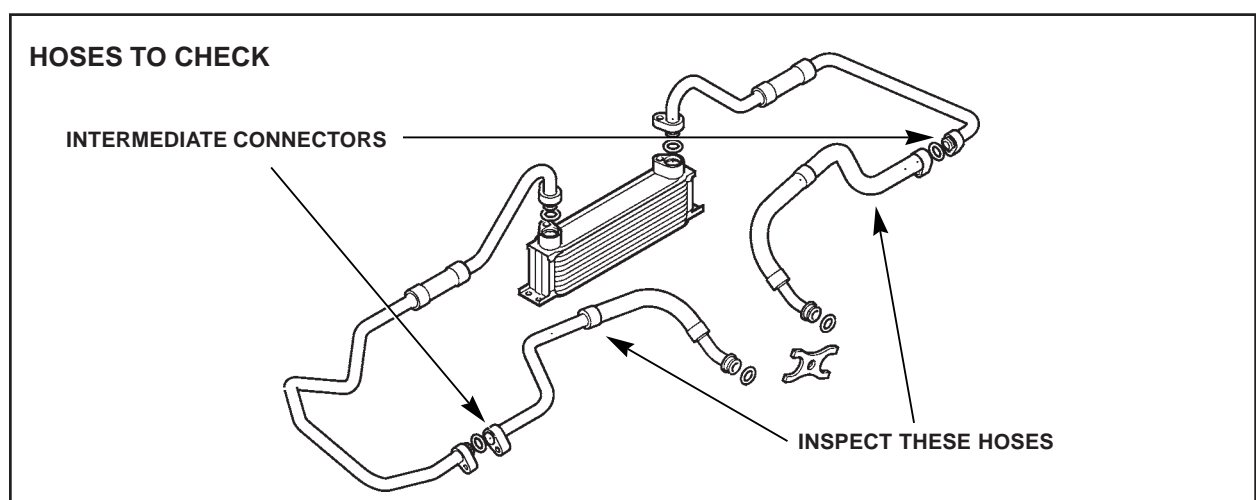

NOTE: THE INFORMATION IN TECHNICAL BULLETINS IS INTENDED FOR USE BY TRAINED, PROFESSIONAL TECHNICIANS WITH THE KNOWLEDGE, TOOLS, AND EQUIPMENT TO DO THE JOB PROPERLY AND SAFELY. IT INFORMS THESE TECHNICIANS OF CONDITIONS THAT MAY OCCUR ON SOME VEHICLES, OR PROVIDES INFORMATION THAT COULD ASSIST IN PROPER VEHICLE SERVICE. THE PROCEDURES SHOULD NOT BE PERFORMED BY "DO-IT-YOURSELFERS." DO NOT ASSUME THAT A CONDITION DESCRIBED AFFECTS YOUR CAR. CONTACT A JAGUAR RETAILER TO DETERMINE WHETHER THE BULLETIN APPLIES TO YOUR VEHICLE.

WORKSHOP PROCEDURE

1. Open door and hood and install exterior vehicle protection.
2. Raise the vehicle.

From under the vehicle:

3. Check the date code (Illustration 1) on the oil cooler feed pipe/hose running from the engine to the intermediate connector and on the oil cooler return pipe/hose from the intermediate connector back to the engine. Use a small mirror if required.

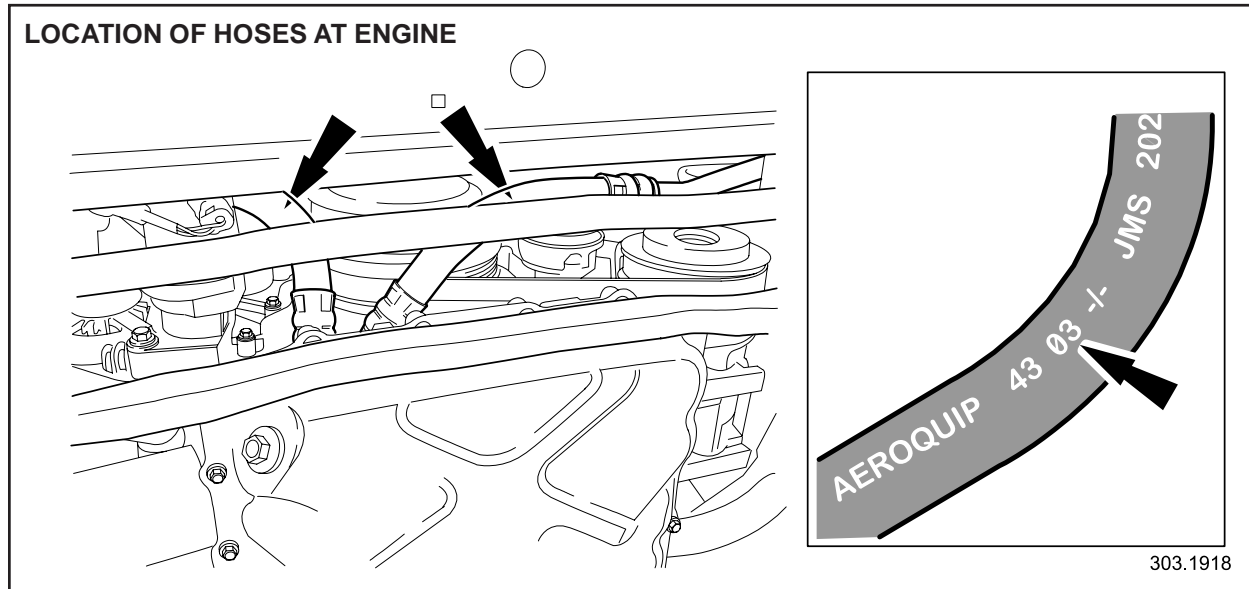

ILLUSTRATION 1

4. If the date code displayed is **43 03** or the code cannot be determined, continue to step 5 of this workshop procedure. If the date code displayed is **not 43 03**, no further action is required. Lower the vehicle.
5. Remove the undertray.
6. Place a suitable drain tray under the vehicle.
7. Remove the oil cooler pipe/hose joint retaining plate securing bolt on the front of the engine (Illustration 2).

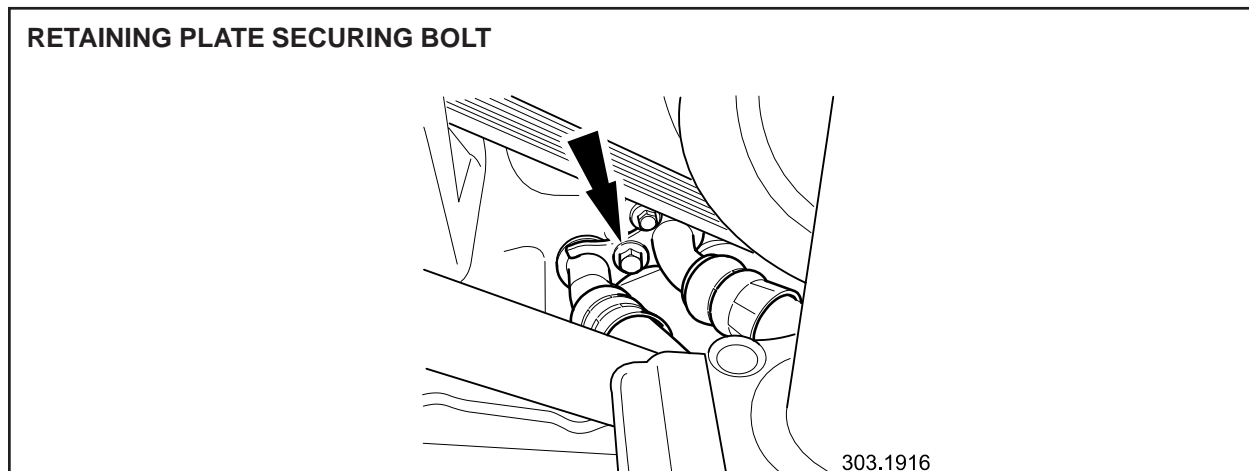
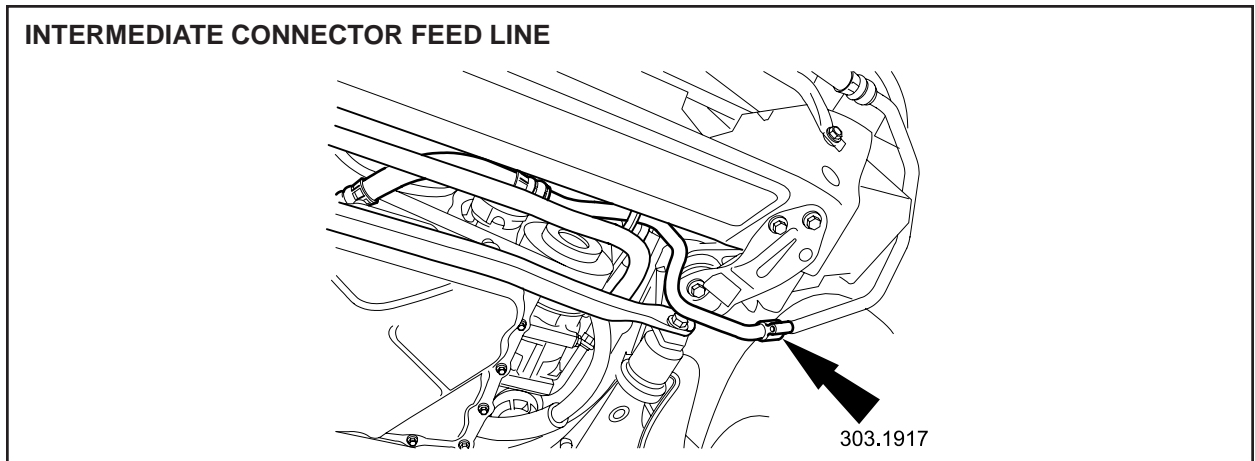

ILLUSTRATION 2

8. Remove the retaining plate.
9. Disconnect the oil cooler feed and return pipe/hoses from the front of the engine port.
10. Install suitable blanking plugs to the front of the engine port and oil cooler pipe/hoses.
11. Remove the oil cooler feed pipe/hose to intermediate connector-securing bolt (Illustration 3).



IILUSTRATION 3

12. Disconnect and remove the oil cooler feed pipe/hose from the intermediate connector.
13. Displace and discard oil cooler pipe O-ring seal.
14. Install suitable blanking plugs to cooler pipe/hoses.
15. Place the new oil cooler feed pipe/hose to the front.
16. Displace and remove the blanking plugs from the cooler pipe/hose.
17. Install and fully seat the new O-ring seal to the cooler feed pipe/hose.
18. Lubricate the new O-ring seal.
19. Reposition and align the oil cooler feed pipe/hose to the intermediate connector and re-connect.
20. Install and tighten intermediate connector securing bolt (Illustration 4).

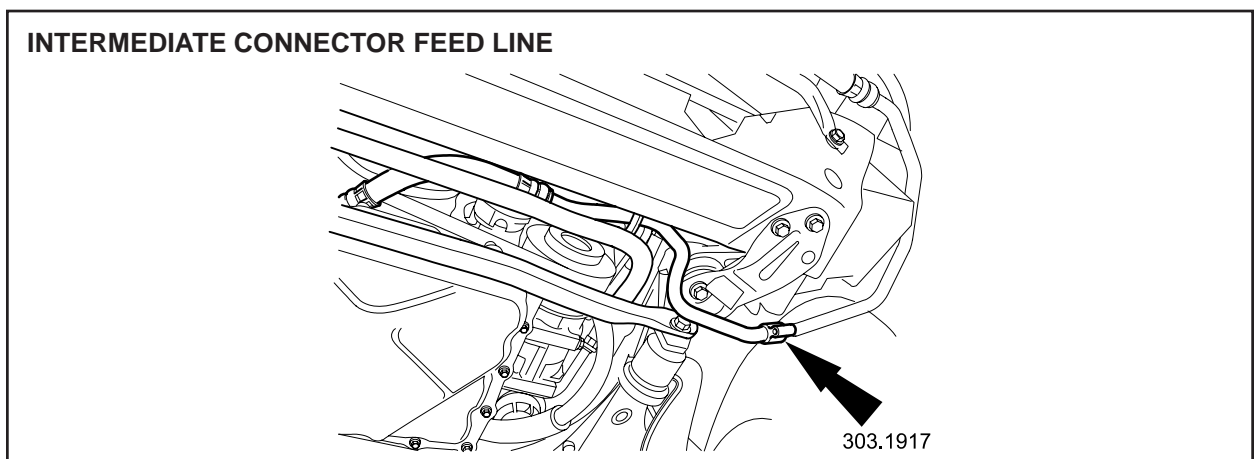

IILUSTRATION 4

21. Undo and remove the oil cooler return pipe/hose to intermediate connector-securing bolt, (Illustration 5).

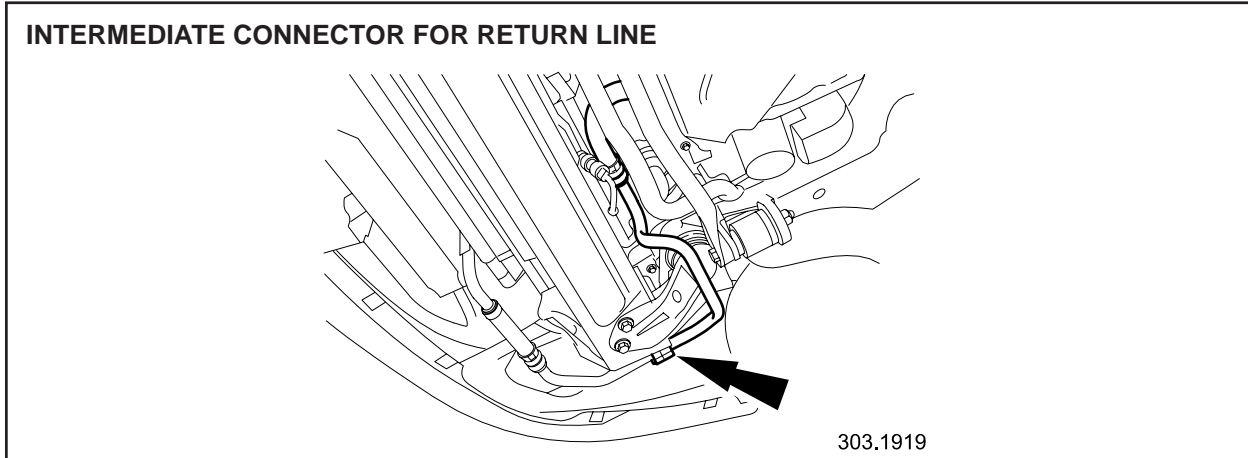

IILLUSTRATION 5

22. Disconnect and remove the oil cooler return pipe/hose from the intermediate connector.
23. Displace and discard oil cooler pipe O-ring seal.
24. Install suitable blanking plugs to cooler pipe/hoses.
25. Place the new oil cooler return pipe/hose to the front.
26. Displace and remove the blanking plugs from the cooler pipe/hose.
27. Install and fully seat the new O-ring seal to the cooler return pipe/hose.
28. Lubricate the new O-ring seal.
29. Reposition and align the oil cooler return pipe/hose to the intermediate connector and reconnect.
30. Install and tighten intermediate connector securing bolt (Illustration 6).

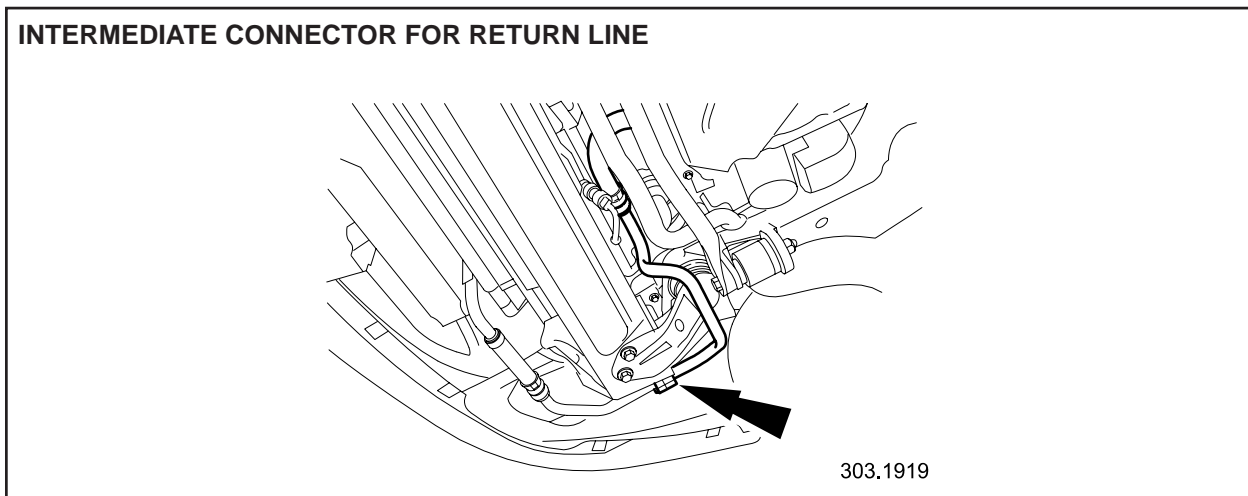

IILLUSTRATION 6

31. Lubricate the oil cooler feed and return pipe/hoses O-ring seals.
32. Reposition and align the oil cooler feed and return pipe/hoses to the engine port.
33. Reconnect the oil cooler feed pipe/hoses to the engine port.
34. Reposition and install the oil cooler pipe/hose retaining plate.
35. Install and tighten the retaining plate securing bolt.
36. Clean spillage from the front of the engine.
37. Remove the drain tray from under the vehicle.
38. Reinstall the undertray.
39. Lower the vehicle.
40. Start and run the engine until the oil pressure rises.
41. Turn off the engine.
42. Check, and if necessary, top up the engine oil.
43. Remove the exterior vehicle protection and close hood and door.

Global Technical Reference (GTR) Workshop Manual Information:

Dealer access: <https://hub.franchise.jaguar.com>

Internet access: <http://www.jaguartechno.com>

Parts Information:

<u>DESCRIPTION</u>	<u>PART NUMBER</u>	<u>QTY</u>
Oil cooler feed pipe/hose (includes O-ring)	C2N 2208	1
Oil cooler return pipe/hose (includes O-ring)	MJE 7461AB	1
O-Ring	KSR 609001	2

Warranty Information:

Warranty claims should be submitted quoting program code S846 together with the appropriate option code from the table below. This will result in payment of the stated time and where applicable parts/miscellaneous expense codes.

The options that allow for drive in/drive out can only be claimed if the vehicle has been brought into the workshop for this action alone to be undertaken.

The SROs, parts and miscellaneous items have been included for information only; there will be no requirement to enter the parts, SROs and miscellaneous items onto the claim.

Service Action S846

Model	Year	VIN Range
XK8	2004 MY	42 A39699 - 42 A40264
XKR	2004 MY	43 A39699 - 43 A40264
XK8	2005 MY	52 A40265 - 52 A41740
XKR	2005 MY	53 A40265 - 53 A41740

Program Code	Option	Description	SRO	Time	Part Number	Part Description	Qty
S846	A	Check date code - no further action required	10.10.99	0.2 hrs.	-	-	-
S846	K	Check date code – no further action required	10.10.99	0.2 hrs.	-	-	-
		Drive in/drive out	10.10.10	0.1 hrs.			
S846	B	Check date code and replace feed and return pipe/hoses	12.92.14	0.7 hrs.	C2N 2208	Oil cooler feed pipe/hose	1
					MJE 7461AB	Oil cooler return pipe/hose	1
					KSR 609001 ZZZ001	O-Ring Top up oil	2 \$5.00
S846	C	Check date code and replace feed and return pipe/hoses	12.92.14	0.7 hrs.	C2N 2208	Oil cooler feed pipe/hose	1
					MJE 7461AB	Oil cooler return pipe/hose	1
					KSR 609001 ZZZ001	O-Ring Top up oil	2 \$5.00
		Drive in/drive out	10.10.10	0.1 hrs.			

Note: Always perform a DDW claim search first to determine whether this service action has been performed on this vehicle. The “Review Claim History” function will provide a listing of all claims against the vehicle. If this service action number appears in the program code field, do not perform this service action.



October 2004

JAGUAR CARS

555 MacARTHUR BOULEVARD

MAHWAH NJ 07430

T 800 4 JAGUAR

www.jaguar.com

RE: S846 Service Action - Oil Cooler Feed Pipe Failure

Dear Jaguar Owner

Jaguar Cars has identified a concern relating to the possibility of the oil cooler feed pipe hose failing. If you are a recipient of this notice, and an owner of one of the vehicles within the VIN range, this letter is to inform you that your vehicle is included in this service action.

The following is a breakdown of the affected vehicles by model and (VIN) range.

➤ 2004 Jaguar XK/XKR A39699 - A41740

What is the concern?

The oil cooler feed pipe hose may fail at the outer crimp of the oil cooler feed pipe/hose, resulting in the possibility of engine oil loss and reduced engine performance.

What will Jaguar and your Jaguar Dealer do?

An authorized Jaguar Dealer will inspect the oil cooler feed pipe/hose for a date code. If the date code is within the effected range the engine oil cooler feed pipe/hose will be replaced.

What should you do?

At your earliest convenience you should contact your authorized Jaguar Dealer who will be able to make an appointment to undertake the necessary actions. To assist your Dealer, please ensure that at the time of contact you have at hand your applicable Vehicle Identification Number.

How long will it take?

The time to complete the repair on your vehicle is approximately one hour. However due to vehicle scheduling your Dealer may need to keep your vehicle longer to complete the repair.

Moved or no longer own a Jaguar?

Please fill out the enclosed card and return it to Jaguar by simply putting it in the mail.

Attention Leasing Agencies

Please forward this Service Action notice to the lessee within 10 days.

What should you do if you have further questions?

Please contact your Jaguar Dealer or the Jaguar Customer Relationship Center at 1 800 4JAGUAR (1-800-452-4827), option 9 or by e-mail at jaguarowner@jaguar.com. Should you have the need to contact Jaguar by mail, please address the correspondence to the Jaguar Customer Relationship Center using the above address.

Sincerely yours,

Benjamin I. Weiner
Customer Satisfaction Manager



MODEL
2007 XK

DATE
06 June 2006

NUMBER
XK303-001

SERVICE

TECHNICAL BULLETIN

SECTION: 303-07

Smart Key Removal from Docking Station

AFFECTED VEHICLE RANGE:

New XK

VIN: All

Model Year: All

CONDITION SUMMARY:

REMOVAL OF SMART KEY FROM DOCKING STATION WITH TRANSIT RELAY INSTALLED



CAUTION: Damage to the Smart Key may occur if procedures are not adhered to.



NOTE: The Smart Key must be correctly inserted into the docking station before starting the vehicle with the Battery Isolation Transit Relay installed.

Situation: This "information only" bulletin has been published to inform dealer personnel of the proper procedures for removing the vehicle Smart Key from the docking station when the Battery Transit Relay is installed.

Action: When the Transit Relay is installed, refer to the Repair Procedures detailed in this bulletin to properly remove the Smart Key from the docking station.



NOTE: A number of production vehicles in the VIN range B04704 to B04753 were built without the return spring installed in the Smart Key docking station cover. The docking station cover will need to be opened and closed manually on these vehicles. The lack of a return spring is not considered a fault. Components associated with the missing return spring are not to be replaced under Warranty.

PARTS:

No parts required. Information purposes only.

WARRANTY:

This bulletin is issued for information purposes only.

Normal warranty policy and procedures apply.

NOTE: The information in Technical Bulletins is intended for use by trained, professional technicians with the knowledge, tools, and equipment required to do the job properly and safely. It informs these technicians of conditions that may occur on some vehicles, or provides information that could assist in proper vehicle service. The procedures should not be performed by "do-it-yourselfers." If you are not a Retailer, do not assume that a condition described affects your vehicle. Contact an authorized Jaguar service facility to determine whether the bulletin applies to a specific vehicle.

REPAIR PROCEDURE

REMOVAL OF SMART KEY WITH TRANSIT RELAY INSTALLED AND ENGINE "OFF"

 **CAUTION:** NO device of any type is to be used to pull the Smart Key out of the docking station slot.

 **NOTE:** After turning the ignition "off" a motor will drive the Smart Key to the ejected position, allowing removal. If the Smart Key does not automatically eject after turning the ignition "off", the following procedure must be followed to eject and safely remove the Smart Key.

1. Ensure the engine has stopped.
2. Ensure the transmission is in the Park position.
(1 in Figure 1)
3. Slide the Smart Key docking station cover to the open position and hold open.
4. Wait 60 seconds.
5. Press downward on the Smart Key and release.
(2 in Figure 1)
6. Observe the key self-eject half way.
(3 in Figure 1)
7. Manually remove the Smart Key from the docking station.

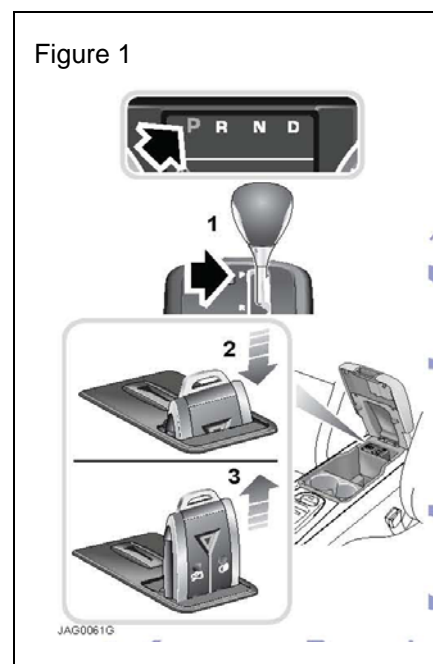



XK

DATE 04/04

307-R513

SERVICE

TECHNICAL BULLETIN

Incorrect Gear Selection –
ZF 6 Speed Automatic Transmission –
Recall Action R513

MODEL 2003-04 MY
XK Range

VIN A29406-A37133

Issue:

A concern has been identified on 2003-04 MY vehicles within the above VIN ranges that are equipped with the six-speed automatic transmission.

If Drive (D) is selected with the vehicle stationary, the transmission may engage Reverse (R) if there is insufficient fluid pressure in the transmission and/or a sticking valve within the transmission. If this condition is present, the vehicle will default to Mechanical Limp Home mode and the Malfunction Indicator Lamp (MIL) will illuminate.

With the vehicle moving in a forward direction, reverse may engage without any manual input when the transmission is in first, second or third gear, as a result of transmission fluid loss allowing the fluid pressure to decrease. The vehicle will default to Mechanical Limp Home mode. The MIL lamp will illuminate if the transmission fluid pressure falls to below 4.1 bar.

Action:

Reprogram the Transmission Control Module (TCM) on all vehicles within the above VIN range, to the latest condition using Worldwide Diagnostic System (WDS) release **JTP 759/29 or later**.

All unsold vehicles or vehicles that have not been handed over to the customer must be repaired prior to sale or onward distribution.

Jaguar will be writing to all owners of affected vehicles requesting them to contact their nearest dealer as soon as possible to arrange for the TCM to be reprogrammed at the earliest opportunity.

To allow the transmission to adapt to the customer's driving requirements after the TCM has been reprogrammed, the vehicle will need to be driven, by the customer, for approximately 50 miles (80 kilometers) without using the sport mode switch. This information must be communicated verbally to the customer when the vehicle is booked

NOTE: THE INFORMATION IN TECHNICAL BULLETINS IS INTENDED FOR USE BY TRAINED, PROFESSIONAL TECHNICIANS WITH THE KNOWLEDGE, TOOLS, AND EQUIPMENT TO DO THE JOB PROPERLY AND SAFELY. IT INFORMS THESE TECHNICIANS OF CONDITIONS THAT MAY OCCUR ON SOME VEHICLES, OR PROVIDES INFORMATION THAT COULD ASSIST IN PROPER VEHICLE SERVICE. THE PROCEDURES SHOULD NOT BE PERFORMED BY "DO-IT-YOURSELFERS." DO NOT ASSUME THAT A CONDITION DESCRIBED AFFECTS YOUR CAR. CONTACT A JAGUAR RETAILER TO DETERMINE WHETHER THE BULLETIN APPLIES TO YOUR VEHICLE.

in for the repair to be undertaken.

The reprogramming of the TCM is dependant upon the temperature of the transmission. If the transmission is not within the specified temperature values for the TCM to be reprogrammed, the retailer will need to consider the level of courtesy service that should be provided to customers while performing this action.

OPEN SERVICE ACTIONS

This is an ideal opportunity to ensure that any outstanding Service Actions are completed on all vehicles included within this Recall Action. A list of the current open service actions is shown below. Please ensure that you check that the vehicle is affected by the service action prior to confirming the booking with your customers so that suitable time and parts are made available prior to the repair visit. This can be done by using the outstanding service action function within DDW, using your own internal records and by checking the original service action bulletin. It is also important that you ensure that the repair has not already been completed, as **NO** repeat service action claims will be accepted.

S506 Lack of Power Assistance - XK

S840 Battery Quiescent Drain - XK

S844 OBD System Readiness Flag P1111 Fails to Set - XKR

WORKSHOP PROCEDURE

Before reprogramming the Transmission Control Module (TCM) ensure that the following requirements are met:

- The Portable Test Unit (PTU) is docked on the WDS base station, with the base station plugged in to line voltage.
 - Vehicle battery is charged to a minimum of 12.5 volts.
 - All Diagnostic Trouble Codes (DTCs) are cleared.
 - Transmission oil temperature is within the recommended value of between minus 55 degrees Celsius and plus 80 degrees Celsius.
1. Open door.
 2. Ensure ignition is switched off, hand brake is on and selector lever is in Park (P).
 3. Position WDS alongside the vehicle, switch WDS on and allow software to load.

Note: WDS must be loaded with the latest issue of software (WDS 29 or later.)

⚠ Caution: Never use software prior to WDS 29 to reprogram the TCM since this will return the calibration to an earlier level.

4. Connect PTU to vehicle using diagnostic cable.
5. Enter the VIN and navigate to the vehicle configuration main menu.

- From the vehicle configuration main menu, navigate to and run the 'Re-configure existing TCM' application.

Note: As part of the reprogram process, a pop up screen stating 'select the access route you require' will be displayed, at this point the technician must select '**normal access**'.

Note: If the message 'The vehicle does not require reprogramming – the latest software is installed. Do you wish to continue?' appears, the dealer **MUST SELECT NO**. This message indicates that the vehicle has undergone a previous software update and does not require reprogramming. No further action is required.

- After successful reprogramming of TCM, switch off, disconnect, and return the WDS to the original location.
- Close door.

APPLYING MODIFICATION LABEL

AUTHORIZED MODIFICATION LABEL	
	AUTHORIZED MODIFICATIONS
	WRITE IN DESCRIPTION
	THE FOLLOWING MODIFICATIONS HAVE BEEN MADE
	<i>RECALL ACTION R513 - REPROGRAMTCM</i>
	THESE MODIFICATIONS HAVE BEEN APPROVED, AS APPROPRIATE.
WRITE IN DEALER NUMBER	DEALER NUMBER: <input type="text"/>
	DATE: <input type="text"/>
	CHANGE AUTHORITY: JAGUAR PLC CAMPAIGN

ILLUSTRATION 1

Fill out an authorized modification label (Illustration 1), enter the dealer number and date on the authorized modification label. List any other service actions that have been performed at the same time. Apply the label to the A-post on S-TYPE and XJ, and on the B-post on XK. Apply the clear sheet over the label.

Warranty Information:

Warranty claims should be submitted quoting program code R513 together with the relevant option code from the table below. This will result in payment of the appropriate time to reprogram the TCM.

The options that allow for drive in/drive out should only be claimed if the vehicle is brought into the workshop for only this recall action.

Recall Action R513

Model	VIN Range
2003 MY XK	32A29406 - 32A36873
2003 MY XKR	33A29406 - 33A36873
2004 MY XK	42A36874 - 42A37133
2004 MY XKR	43A36874 - 43A37133

Program Code	Option	Description	SRO	Time	Part Number	Part Description	Qty
R513	B	Re-program TCM	86.93.36	0.4 hrs.	-	-	-
R513	C	Re-program TCM	86.93.36	0.4 hrs.	-	-	-
		Drive in/drive out	10.10.10	0.1 hrs.			

NOTE: Always perform a DDW claim search first to determine whether this recall action has been performed on this vehicle. The "Review Claim History" function will provide a listing of all claims against the vehicle. If this recall action number appears in the program code field, do not perform this recall action.



Technical Service Bulletin

No.JTB00070
29 November 2007

Subject/Concern: Transmission Noise During Gearshifts - Gasoline

Models:		
S-TYPE	Gasoline Only	Gasoline Only VIN-range: M45255-N52047
XJ Range	Gasoline Only	Gasoline Only VIN-range: G00442-G49700
XK Range	Gasoline Only	Gasoline Only VIN-range: A30645-A48684

Markets: All

Section: 307-00

Summary:
Transmission noise (squawk) during gearshifts. Cause: Clutch slip due to low fill pressure adaption. Suggested Customer Concern Code - P66. Action: Should a customer express concern, add transmission fluid additive to modify friction. Follow the Service Instruction outlined below.

Parts Required:		
Description	Part Number	Quantity
Transmission fluid additive	C2C 37157	1
Transmission fluid (as required)	C2C 8432	1

Labour Time:		
Operation Description	Operation No.	Time
Transmission noise service procedure - XJ Range	44.91.35	0.9 hours
Transmission noise service procedure - XK Range and S-TYPE	44.91.35	1.0 hour

Repair/Claim Coding:	
Causal Part:	C2C 37157
ACES Condition Code:	42
Defect Code:	

Service Instruction

The additive must only be used in the following cases:

- a) To fix a transmission noise during gearshifts (squawk).
- b) **It must only be used once in a transmission.** The exception to this rule is if the transmission has had a complete fluid change, where a second application may be used on a customer complaint of transmission squawk.

The additive must not be used in the following circumstances:

- c) It must not be used in an attempt to fix any other transmission concerns, for example noises other than squawk, harsh transmission shifts, or Diagnostic Trouble Codes (DTC) logged in the transmission control module.
- d) **The additive must not be used on any cars outside the VIN range detailed in this Technical Bulletin.**
- e) The additive must not be used more than once in a transmission (apart from the exception described in item 'b').
- f) Do not use the additive as a preventative measure. It must not be used unless there is transmission noise during gearshifts (squawk) present. Do not add the fluid during initial oil fill when a new or remanufactured transmission is installed.
- g) The effects of using the additive incorrectly (as in items c, d, e, or f) may be reduced friction of the clutches leading to poor shift quality, DTCs logged, and it can also induce flare.



CAUTION: If the service fix label is already attached to the transmission oil pan, do NOT carry out the Service Instruction as this can cause severe damage to the transmission.

1. Raise vehicle on a four-post ramp.
2. Remove the engine undertray.

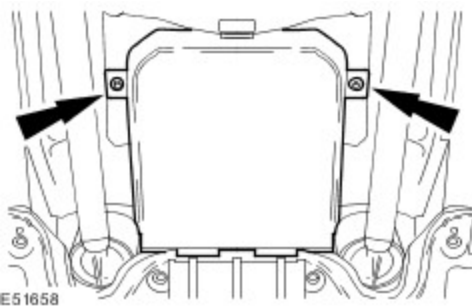

3. Place clean drain container under the transmission.
- 4.



CAUTION: Ensure the transmission is cold before removing the fluid drain plug. Do not fully remove the drain plug as only one litre of fluid is to be

collected.

NOTE: XJ Range shown; S-TYPE and XK similar.

Undo and partially remove the transmission fluid drain plug.

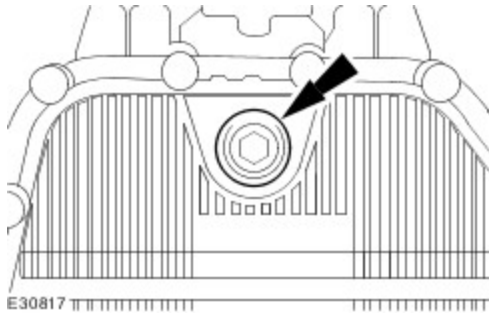

- 5 . Collect one litre of fluid from the transmission into a clean measuring jug.
- 6 . Reinstall and tighten the transmission fluid drain plug to 8Nm.
- 7 . Ensure the selector lever is in 'P' and the handbrake is applied.
- 8 . Start the engine and allow to idle.
- 9 . Unscrew transmission filler plug and fill with one litre of the additive (C2C 37157) using a clean syringe.
- 10 . Pull the service fix label off the bottle and paste it onto the transmission oil pan, near the filler plug.

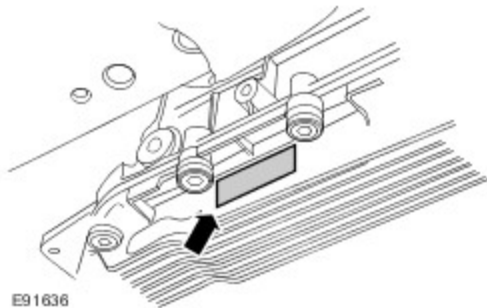

- 11 . Check and top-up the transmission fluid level (see Global Technical Reference GTR Workshop Manual, section: 307-01).

©2007 Jaguar

A/C - Water Leaks Onto Passenger Floor

No: JTB00121

Issue: 4

Date: 02 FEB 2010

ISSUE '4' CHANGES ARE EXTENSIVE AND ARE NOT HIGHLIGHTED

SECTION: 412

Water Ingress into Passenger Footwell
AFFECTED VEHICLE RANGE:

XK (X150) VIN: B00001 - B33100
 Model Year: 2007 - 2009

CONDITION SUMMARY:

Situation:

An issue has been identified where water may leak into the passenger footwell. This may be caused by a trapped / blocked air conditioning drain tube.

Action:

In the event of a customer concern of the above, and after confirming that a trapped / blocked air conditioning drain tube is the cause, refer to the Repair Procedure outlined below to install a new air conditioning drain tube.

C2P 16264Drain tube	Qty: 1
----------------------------------	---------------

PARTS

TOOLS:

Refer to Workshop Manual (GTR) for required special tools

<i>Description</i>	<i>SRO</i>	<i>Time (hours)</i>	<i>Condition Code</i>	<i>Causal Part</i>
Replace A/C drain tube	82.91.33	2.80	55	C2P 16264

Normal warranty policy and procedures apply.

WARRANTY:

NOTE:

Repair procedures are under constant review, and therefore times are subject to change; those quoted here must be taken as guidance only. Always refer to DDW to obtain the latest repair time.

DDW requires the use of causal part numbers. Labor only claims must show the causal part number with a quantity of zero.

REPAIR PROCEDURE:

REMOVE A/C DRAIN TUBE

NOTE:

Global Technical Reference (GTR) lookup sequence is as follows: GTR Home > NAS > X150 - XK > Service Information > Model Year > Workshop Manual

1. Refer to Workshop Manual (GTR) Section 501-12, Instrument Panel and Heating, and remove the instrument panel.

CAUTION:

Care should be taken to ensure no further damage is caused to the vehicle interior. When removing a Heating Ventilation Air Conditioning (HVAC) unit which has shown signs of leaking from the blower motor, approximately one (1) liter of water will remain in the unit which will drain out when the seal to the bu khead is broken.

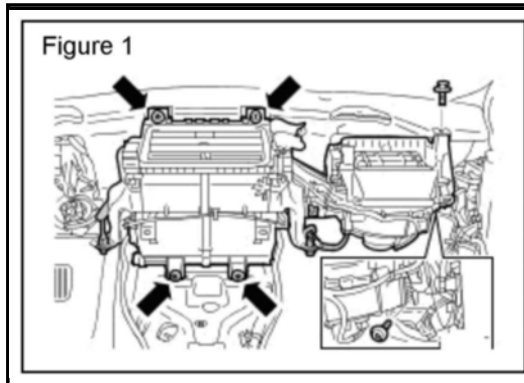

2. Release the heater and evaporator core housing for access to the drain tube (Figure 1):

^Move the carpet for access

^Release both footwell lamp holders.

^Disconnect the two electrical connectors.

^Remove the four nuts.

^Remove the bolt.

VIN range B00001 - B25390 only

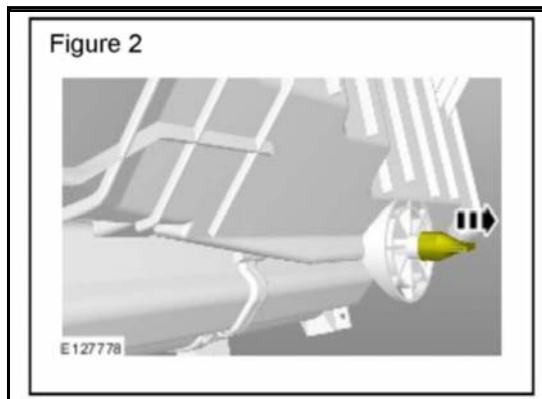

3. Remove and discard the drain tube from the rear of the heater unit. (Figure 2)

VIN range B25391 - B33100 only

Figure 3



4. Remove and discard the drain tube from the bulkhead. (Figure 3)

NOTE:

The plastic peg is not visible; it can be felt through the drain hole from inside the vehicle.

VIN range B30500 - B33100 only

Figure 4



5. Using suitable long-nose pliers, remove and discard the plastic peg contacting the drain tube. (Figure 4)

INSTALL NEW A/C DRAIN TUBE

Figure 5



1. Install a new drain tube into the bulkhead. (Figure 5)

2. Insert a length of suitable hose into the drain tube.

3. Pour a small amount of water into the drain tube.

4. Verify the water exits below the vehicle.

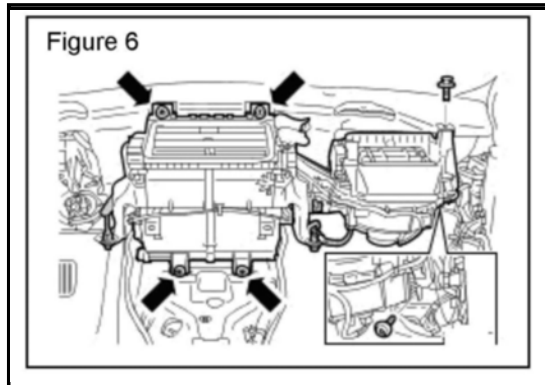

5. Install the heater and evaporator core housing (Figure 6):

^Tighten the bolt to 7 Nm +/- 1.1 Nm (5 lbf ft +/- 0.8 lbf ft).

^Tighten the four bolts to 7 Nm +/- 1.1 Nm (5 lbf ft +/- 0.8 lbf ft).

^Connect the two electrical connectors.

^Install the two footwell lamp holders.

^Install the carpet.

6. Refer to Workshop Manual (GTR) Section 501-12, Instrument Panel and Heating, and install the instrument panel.



MODEL
2007 XK

DATE
06 Apr 2006

NUMBER
XK419-001

SERVICE

TECHNICAL BULLETIN

SECTION: 419-07

MPH Reset for Navigation Screen

AFFECTED VEHICLE RANGE:

New XK

VIN: B00001 onwards

Model Year: 2007 onwards

CONDITION SUMMARY:

PROCEDURE TO RESET NAVIGATION SYSTEM UNITS

This bulletin has been issued to inform dealers of a potential Navigation Screen display error. Some vehicle Navigation Screens may display metric units, when the instrument cluster displays English units. A Navigation System software error may be the cause. An incorrect unit display can occur following a battery reset or software download. The software error can be corrected through the touch screen.



NOTE: A post-launch software update will correct this error.

Situation: Navigation System software error results in incorrect units of measure display.

Action: Should a vehicle Navigation Screen display metric units, while the instrument cluster displays English units, refer to the Repair Procedure detailed in this bulletin to manually reset the navigation system software to compute and display English units.

PARTS:

No parts required. Information purposes only.

WARRANTY:



NOTE: The manual Navigation System resetting procedure is covered in the PDI so this manual navigation system resetting procedure can only be claimed for a battery reset or software download after completing the vehicle PDI.



NOTE: Repair procedures are under constant review, and therefore times are subject to change; those quoted here must be taken as guidance only. Always refer to DDW to obtain the latest repair time.

DDW requires the use of causal part numbers. Labor only claims must show the causal part number with a quantity of zero.

<i>Description</i>	<i>SRO</i>	<i>Time (Hours)</i>	<i>Condition Code</i>	<i>Causal Part</i>
Manually reset satellite navigation system	86.93.63	0.20	(as required)	C2P4480

Normal warranty policy and procedures apply.

NOTE: The information in Technical Bulletins is intended for use by trained, professional technicians with the knowledge, tools, and equipment required to do the job properly and safely. It informs these technicians of conditions that may occur on some vehicles, or provides information that could assist in proper vehicle service. The procedures should not be performed by "do-it-yourselfers."

If you are not a Retailer, do not assume that a condition described affects your vehicle. Contact an authorized Land Rover service facility to determine whether the bulletin applies to a specific vehicle.



TECHNICAL BULLETIN

NUMBER
XK419-001

REPAIR PROCEDURE

MANUALLY RESET NAVIGATION SYSTEM SOFTWARE TO COMPUTE AND DISPLAY ENGLISH UNITS

1. From the Navigation System home screen, select 'Vehicle'.
2. Select 'Trip Comp'.
3. Select 'Units'.
4. Select and hold 'KM' for 15 seconds.
5. Select 'Miles'.
6. Return to Navigation screen and confirm changes.



MODEL
2007 XK

DATE
06 Apr 2006

NUMBER
XK419-002

SERVICE

TECHNICAL BULLETIN

SECTION: 419-10

Falsely Flagged Diagnostic Trouble Codes

AFFECTED VEHICLE RANGE:

New XK

VIN: B00001 onwards

Model Year: 2007

CONDITION SUMMARY:

FALSELY FLAGGED DIAGNOSTIC TROUBLE CODES (DTC)

This bulletin has been issued to inform the dealers of a number of DTC that can be falsely flagged.

Situation: This bulletin identifies a number of DTC's that may be cleared and ignored. The Integrated Diagnostic System (IDS) "help text" may provide alternative actions for some codes.

Action: Refer to the appended table of codes associated with various vehicle modules that under most circumstances can be ignored or simply explained by the "Service Notes" information.

PARTS:

No parts required. Information purposes only.

WARRANTY:

Normal warranty policy and procedures apply.

NOTE: The information in Technical Bulletins is intended for use by trained, professional technicians with the knowledge, tools, and equipment required to do the job properly and safely. It informs these technicians of conditions that may occur on some vehicles, or provides information that could assist in proper vehicle service. The procedures should not be performed by "do-it-yourselfers."
If you are not a Retailer, do not assume that a condition described affects your vehicle. Contact an authorized Land Rover service facility to determine whether the bulletin applies to a specific vehicle.

REPAIR PROCEDURE

IDENTIFY AND CLEAR DIAGNOSTIC TROUBLE CODES

DTC	ECU	Description	Service Notes
B100B-67	Instrument Cluster (IC) Module	Column lock ground authorization - signal incorrect after event.	Clear and ignore this DTC, unless IDS help text states otherwise.
B100B-87	IC Module	Column lock ground authorization - missing message.	Clear and ignore this DTC, unless the driver has complained of engine non-start, or IDS help text states otherwise.
B100C-67	IC Module	Column lock supply authorization - signal incorrect after event.	Clear and ignore this DTC, unless IDS help text states otherwise.
B100C-87	IC Module	Column lock supply authorization - missing message.	Clear and ignore this DTC, unless the driver has complained of engine non-start, or IDS help text states otherwise.
B1026-13	Central Junction Box (CJB)	Steering column lock - open circuit.	Clear and ignore this DTC, unless IDS help text states otherwise.
B108A-29	CJB	Start button - signal invalid.	Clear and ignore this DTC, unless driver has complained of 'Engine System Fault' warning message. or IDS help text states otherwise.
B1318-00	Parking Brake Module (PBM)	Low voltage.	On CD43 - Before taking further action check the Electronic Park Brake (EPB) manufacturer module software number. The software version can be obtained by running the network integrity test from 'Configuration' menu. This will give a base number of 6W83-14C168 followed by a 2 digit suffix. If the suffix reads AB or below, this DTC is invalid for this vehicle variant and no rectification work is required. If the suffix reads AC or higher, the DTC is valid for this vehicle variant and rectification work is required. Refer to 'Diagnosis and Testing' in GTR to help diagnose the fault(s) associated with this DTC.

DTC	ECU	Description	Service Notes
B1A85-15	Instrument Cluster (IC) Module	Ambient light sensor - circuit short to battery or open circuit.	Clear and ignore this DTC, unless IDS help text states otherwise. Confirm sensor is working using auto headlamps.
B1B01-67	IC Module	Key transponder - signal incorrect after event.	Unless IDS help text states otherwise, clear and ignore this DTC. If B1B33(64) (Target ID transfer - signal plausibility failure) is also logged, see help text for B1B33(64), otherwise run 'Key Verify' to ensure transponders are working.
B1B33-64	IC Module	Target ident. transfer - signal plausibility failure.	Clear and ignore this DTC, unless the driver has complained of engine non-start, or IDS help text states otherwise.
B1B74-00	Automatic Temperature Control (ATC) Module	Front foot-defrost mode stepper actuator.	This DTC is unreliable. The following steps need to be taken to determine if the DTC has logged for valid reasons: Step 1 - A battery reset, low battery voltage or occasionally engine cranking can cause this DTC to log, if a battery reset or low battery voltage has not happened since the last clearance of DTC from the control module. Step 2 - Investigate the fault. Step 3 - If a hard fault has been found, fix fault. Step 4 - If a hard fault has not been found, ignore the DTC. No further rectification work is required. NOTE: This DTC cannot be rectified by running the software download procedure.
B1B75-00	ATC Module	Front foot-face mode stepper actuator.	Same as above.
B1B76-00	ATC Module	Front left air blend stepper actuator.	Same as above.
B1B77-00	ATC Module	Front right air blend stepper actuator.	Same as above.
B2A90-16	Battery Junction Box (BJB)	Battery voltage low.	Perform a battery check in accordance with GTR procedures: Battery Care Manual. Clear the DTCs after noting them in a service report/log, along with their snapshot data. NOTE: This is an information-only DTC and must not be used to change batteries without supplementary testing as outlined above.



TECHNICAL BULLETIN

NUMBER
XK419-002

DTC	ECU	Description	Service Notes
P0232-00	Engine Control Module (ECM)	Fuel pump secondary circuit high.	Ignore this DTC unless P008700 'Fuel Rail/System Pressure - Too Low' is also logged.
U0405-83	ECM	Invalid data received from Cruise Control Module (CCM) - value of signal protection calculation incorrect.	This DTC occurs when invalid cruise control switch data is received from the Steering Wheel Module (SWM). However, the DTC can be produced by the driver inserting an object (including a key fob) into the Starter Control Unit (SCU). The driver would see 'Cruise not available' displayed within a few seconds of inserting the object. Confirm with the driver when fault occurred. If the fault occurs without using the SCU, confirm operation of the SWM.
U0405-8F	ECM	Invalid data received from CCM - erratic.	Same as above.
U0417-81	Adaptive Speed Control Module (ASCM)	Invalid data received from EPB.	Check for DTCs in Electric Park Brake (EPB) system and rectify. This DTC can remain in the Adaptive Cruise Control (ACC) system even after EPB faults have been rectified and all DTCs on the vehicle cleared. In this situation perform an ignition cycle to reset the EPB then clear ACC DTCs again. Re-read the ACC DTCs to confirm code has now cleared.
U0422-00	Parking Brake Module (PBM)	Invalid data received from front smart junction box.	Same as above.
U2012-08	Driver Door Module (DDM)	Car Configuration File (CCF) parameters - bus signal/message failures.	On vehicles prior to VIN B01982, clear and ignore this DTC.
U2012-08	Passenger Door Module (PDM)	Car Configuration File (CCF) parameters - bus signal/message failures.	On vehicles prior to VIN B01982, clear and ignore this DTC.
U2100-00	DDM	Initial configuration not complete.	On vehicles prior to VIN B01982, clear and ignore this DTC.

DTC	ECU	Description	Service Notes
U2100-00	PDM	Initial configuration not complete.	On vehicles prior to VIN B01982, clear and ignore this DTC.
U3000-55	Integrated Control Panel	Control module not configured.	Clear and ignore this DTC, on Integrated Control Panel (ICP) software 6W83-14C535-AA.
U3000-87	Integrated Control Panel	Control module missing message.	Clear and ignore this DTC, on ICP software 6W83-14C535-AA.
U3003-17	Dynamic Stability Control Module (DSCM)	Over voltage.	This DTC can occur while the Battery Isolation Transit Relay is installed.
U3003-62	Information and Entertainment Control Module	Battery voltage - signal compare failure.	Clear and ignore this DTC, unless IDS helptext states otherwise.
U3003-62	Keyless Vehicle Module	Battery voltage - signal compare failure.	Clear and ignore this DTC, unless IDS helptext states otherwise.
U3003-62	Parking Brake Module (PBM)	Battery voltage - signal compare failure.	Same as above.



MODEL
ALL

DATE
22 Jun 2006

NUMBER
JAGA501-001

SERVICE

TECHNICAL BULLETIN

SECTION: 501-11

Windshield Damage Diagnostic Aid

AFFECTED VEHICLE RANGE:

All Jaguar Vehicles

CONDITION SUMMARY:

INTERPRETATION OF GLASS DAMAGE SYMPTOMS

Situation: This information only bulletin has been issued to aid dealers to determine whether windshield damage has been caused by an outside influence, or a manufacturing concern.

Action: Follow the steps outlined in the Repair Procedure to determine whether windshield damage has been the result of outside damage.

PARTS:

Information only

WARRANTY:



NOTE: The following pages offer illustrations of common windshield damage conditions and how to determine if the damage is a result of outside influences (not warrantable) or of manufacturing problems (warrantable)

Normal warranty policy and procedures apply.

NOTE: The information in Technical Bulletins is intended for use by trained, professional technicians with the knowledge, tools, and equipment required to do the job properly and safely. It informs these technicians of conditions that may occur on some vehicles, or provides information that could assist in proper vehicle service. The procedures should not be performed by "do-it-yourselfers."
If you are not a Retailer, do not assume that a condition described affects your vehicle. Contact an authorized Jaguar service facility to determine whether the bulletin applies to a specific vehicle.

Service Information

Diagnosis

1. Clean damaged windshield area.
2. Perform visual inspection for signs of impact.
Low impact damage will appear as a small point along a single crack and can be confirmed by the pen test (see step 6). Moderate impact damage will appear as multiple cracks radiating from a point. High impact damage appears as many cracks radiating from the impact area.
3. If visual inspection and pen test do not show surface damage, point a flashlight at a 45 degree angle along the cracks in the black painted area of the windshield (see illustration E80543 in step 7).
4. Look for radial cracks similar to illustration E80544 (step 8).
5. If radial cracks are present, then cracks are caused by a stone impact and are not warrantable.
6. Slowly run the tip of a ballpoint pen along the crack. If there is an impact present, the tip will catch in the depression caused by the impact.

Examples of Damaged Windshields Caused by Stone Impact

7. Flashlight test.

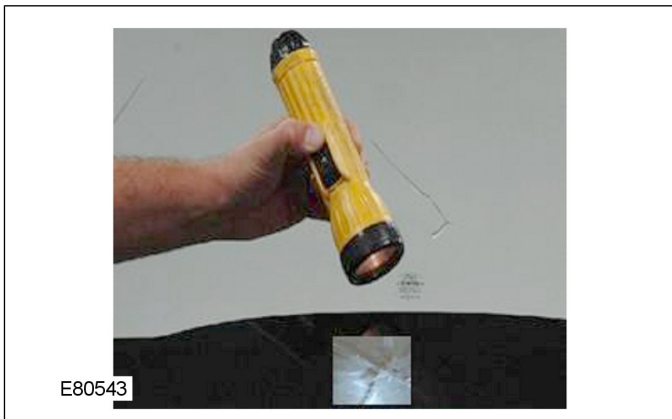

8. View from outside using flashlight (radial cracks).
Several radial cracks emanate from origin point.

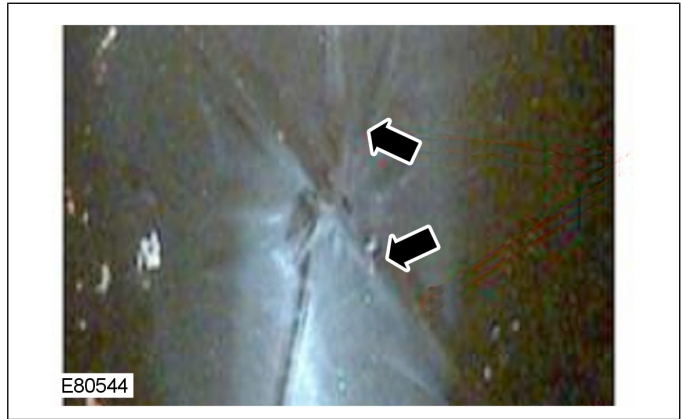

9. Low impact resulting in single crack.

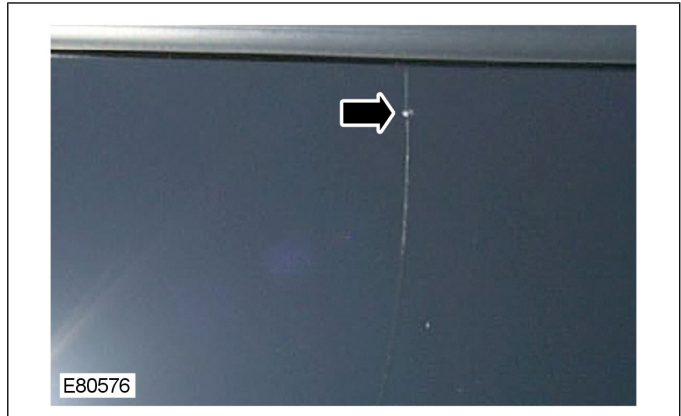

10. Moderate impact resulting in several cracks.

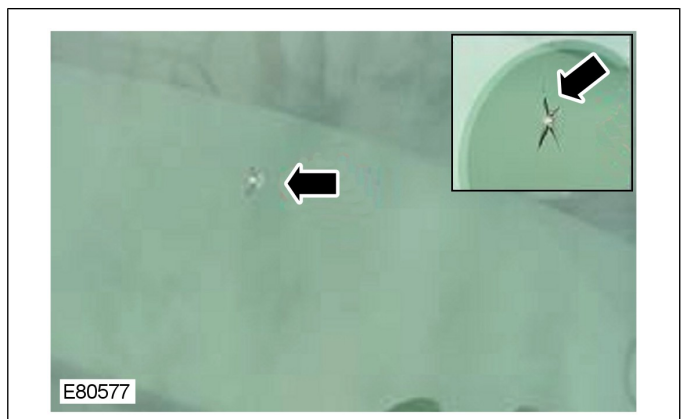

11. High impact resulting in many cracks.



Examples of Damaged Windshields Caused by Stone Impact at the Black Paint Area

NOTE: The three examples below all show evidence linking to stress cracking. This must be confirmed using the ballpoint pen test previously described (in step 6) before any claim is made. Claims subsequently found to be caused by small stone damage will be rejected.

12. Crack along cowl.

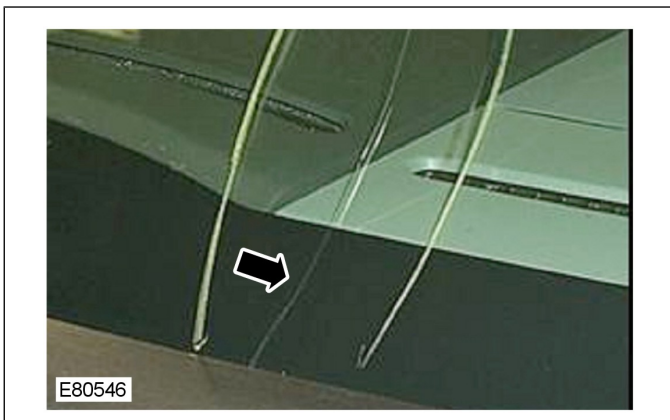

13. Crack along roof line.



14. Crack along A-pillar.



Examples of Windshield Defect Covered by Warranty

NOTE: Warrantable items include imperfections in glass manufacturing and factory assembly such as: distortion, delamination, spalling, bubbles, visual flaws between windshield layers and stress cracks.

15. Distorted glass.



16. Bubbles (Delamination).

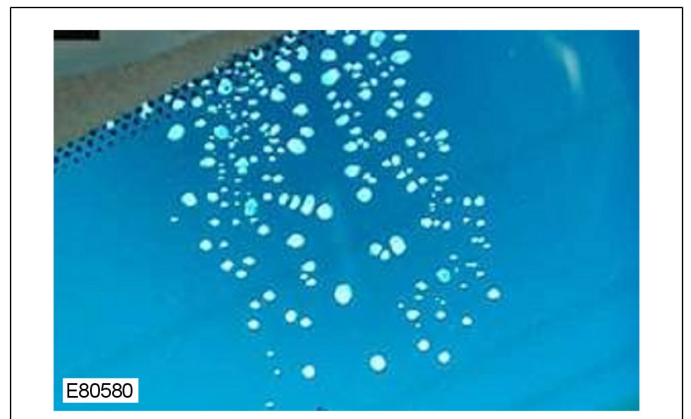

17. Edge delamination (Spalling).

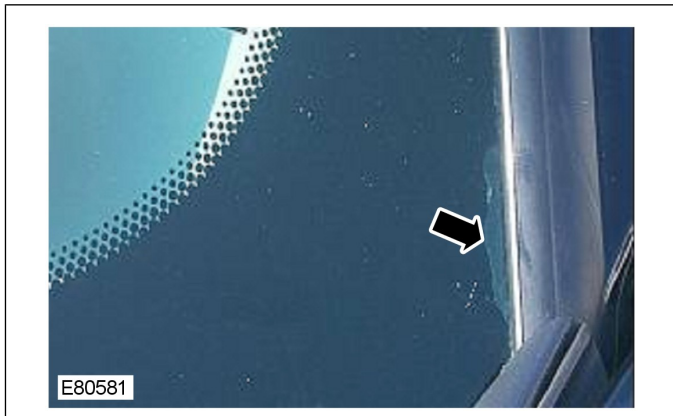



MODEL
2007 XK

DATE
05 Apr 2006

NUMBER
XK501-001

SERVICE

TECHNICAL BULLETIN

SECTION: 501-00

Pre-PDI Activities With Transit Relay Installed

AFFECTED VEHICLE RANGE:

XK (X150)

VIN: B00379 onward
Model Year: 2007

CONDITION SUMMARY:

SPECIAL CONDITIONS BEFORE TRANSIT RELAY REMOVAL



CAUTION: Vehicle operation issues and trim damage may occur if specified procedures are not adhered to.

Situation: This "information only" bulletin is issued to alert dealer personnel about door glass closing, seat adjustment and closing doors with the engine running issues before PDI removal of the transit relay.

Action: Observe the Cautions and special procedures in the "REPAIR PROCEDURE" section of this bulletin. Engine starting procedures, door opening and closing sequences and seat movements with the transit relay installed require strict adherence to the defined processes.

PARTS:

No parts required

WARRANTY:



NOTE: A warranty claim for rear quarter trim replacement may not be submitted if the trim panel is damaged as a consequence of the dealer not following the correct seat adjustment procedures.

This bulletin issued for information purposes only

Normal warranty policy and procedures apply.

NOTE: The information in Technical Bulletins is intended for use by trained, professional technicians with the knowledge, tools, and equipment required to do the job properly and safely. It informs these technicians of conditions that may occur on some vehicles, or provides information that could assist in proper vehicle service. The procedures should not be performed by "do-it-yourselfers."
If you are not a Retailer, do not assume that a condition described affects your vehicle. Contact an authorized Land Rover service facility to determine whether the bulletin applies to a specific vehicle.

PROCEDURE

⚠ CAUTION: The procedures described below must be followed when a transit relay is installed in the vehicle prior to the PDI procedure. The removal of the transit relay is the first step of the PDI process, but vehicle transportation and lot movements may require observance of these limitations.

DOOR CLOSING WITH TRANSIT RELAY INSTALLED

⚠ NOTE: The transit relay "time-out period" is 15 seconds. If the transit relay times out before a door is closed, the window on that door will not return to its fully closed position.

1. Ensure that all doors are closed before the transit relay time-out period expires.
2. If the window does not return to its fully closed position on door closure, open and re-close the door from outside the vehicle using the **exterior** door handle.

SEAT ADJUSTMENT WITH TRANSIT RELAY INSTALLED

⚠ CAUTION: If the following procedure is not carried out prior to adjustment, there is a possibility of damage to the rear quarter trim.

1. Prepare the vehicle for seat adjustment as follows:
 - Insert smart key into docking station.
 - Verify that the gearshift lever is in the "P" Park position.
 - Press start/stop button once to switch the ignition/electrical system 'ON'.
2. Adjust the seats as required.
3. Press start/stop button once to turn off the ignition.

DOOR CLOSING WHEN THE ENGINE IS RUNNING WITH THE TRANSIT RELAY INSTALLED

⚠ CAUTION: When starting, and running or driving the vehicle, it is imperative that the doors are closed and the smart key properly "docked" before starting the engine.

1. If for any reason it is necessary to open and close a door or luggage compartment while the engine is running and the transit relay remains installed, switch the ignition 'OFF' before **closing** the door or luggage compartment.

⚠ NOTE: The vehicle "smart key" can self-eject halfway when the vehicle engine is stopped. It must be fully engaged before the engine will start again.

2. If the vehicle is to be restarted, verify that the vehicle smart key is fully engaged in the center console location.

⚠ CAUTION: The smart key must not be forcibly removed or pulled when it is inserted into the slot. The procedure below must be used to eject and then remove the key.

3. When leaving the vehicle ensure the engine has stopped and remove the smart key from the vehicle as follows: (Figure 1)
 - Press downward on the smart key
 - Observe the key self-eject half way
 - Manually remove the smart key from the vehicle

Figure 1

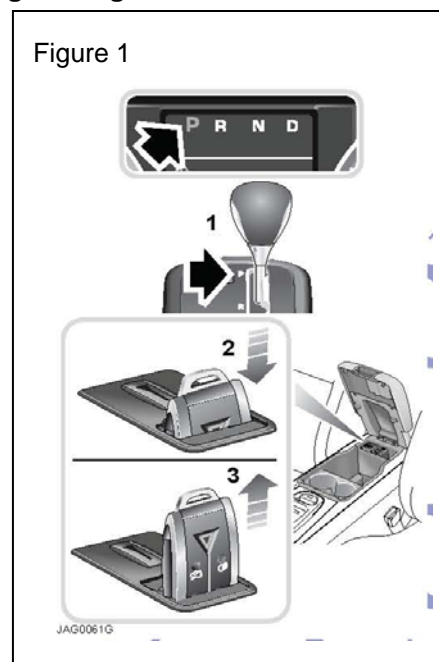



MODEL
2007 XK

DATE
20 Apr 2006

NUMBER
XK501-002

SERVICE

TECHNICAL BULLETIN

SECTION: 501-00

Exterior Paint Issues Reporting Aid

AFFECTED VEHICLE RANGE:

New XK

VIN: ALL

CONDITION SUMMARY:

GRID LOCATION REPORTING OF EXTERIOR PAINT FLAWS

Situation: To assist Jaguar engineering in accurately identifying and categorizing reported exterior paint flaws, model specific exploded body panel diagrams have been created to provide a grid reporting notation system.

Action: Refer to the appropriate model body panel diagram to identify the grid coordinates for any reported exterior paint flaw. The grid coordinates are to be provided with submitted Warranty Claims and Electronic Product Quality Reports (EPQRs).

PARTS:

No parts required.

WARRANTY:

Information purposes only.

Normal warranty policy and procedures apply.



NOTE: Dealers are responsible for ensuring that vehicles accepted from the carriers are in good condition. Damage, including inward dents, scratches, etc. must not be claimed under warranty. Any such transportation damage should be recorded, reported and claimed in accordance with the Warranty Policy Procedure Manual.



NOTE: The body panel diagram is not required to be sent to Jaguar, but should be retained in the Service file for reference.

The vehicle silhouette is required to be filed with the Repair Order as part of the documentary records should be model specific using the supplied diagrams. The new model silhouettes will also be available on version 10 of the RTS disc.

Paint flaw descriptions may be found in the Exterior Body & Paint PDI Cosmetic Sign-Off Standard.

NOTE: The information in Technical Bulletins is intended for use by trained, professional technicians with the knowledge, tools, and equipment required to do the job properly and safely. It informs these technicians of conditions that may occur on some vehicles, or provides information that could assist in proper vehicle service. The procedures should not be performed by "do-it-yourselfers." If you are not a Detailer, do not assume that a condition described affects your vehicle. Contact an authorized Jaguar service facility to determine whether the bulletin applies to a specific vehicle.

REPAIR PROCEDURE

USE GRID CHART TO REPORT PAINT FLAWS



NOTE: Where possible, electronic photographs should be submitted with EPQR's to supplement the grid location and description information.

1. Inspect exterior body paint to identify paint flaws.
2. Refer to Attachment 1 or 2 body panel diagram and determine the X-Y grid coordinates for each paint flaw.



NOTE: As an example, "Paint Run at X24-Y48" would indicate a paint run on the central hood area.

3. Complete the appropriate Warranty Claim or Electronic Product Quality Report (EPQR) and include the grid coordinates, flaw description, and electronic image if an EPQR.

Attachment 1

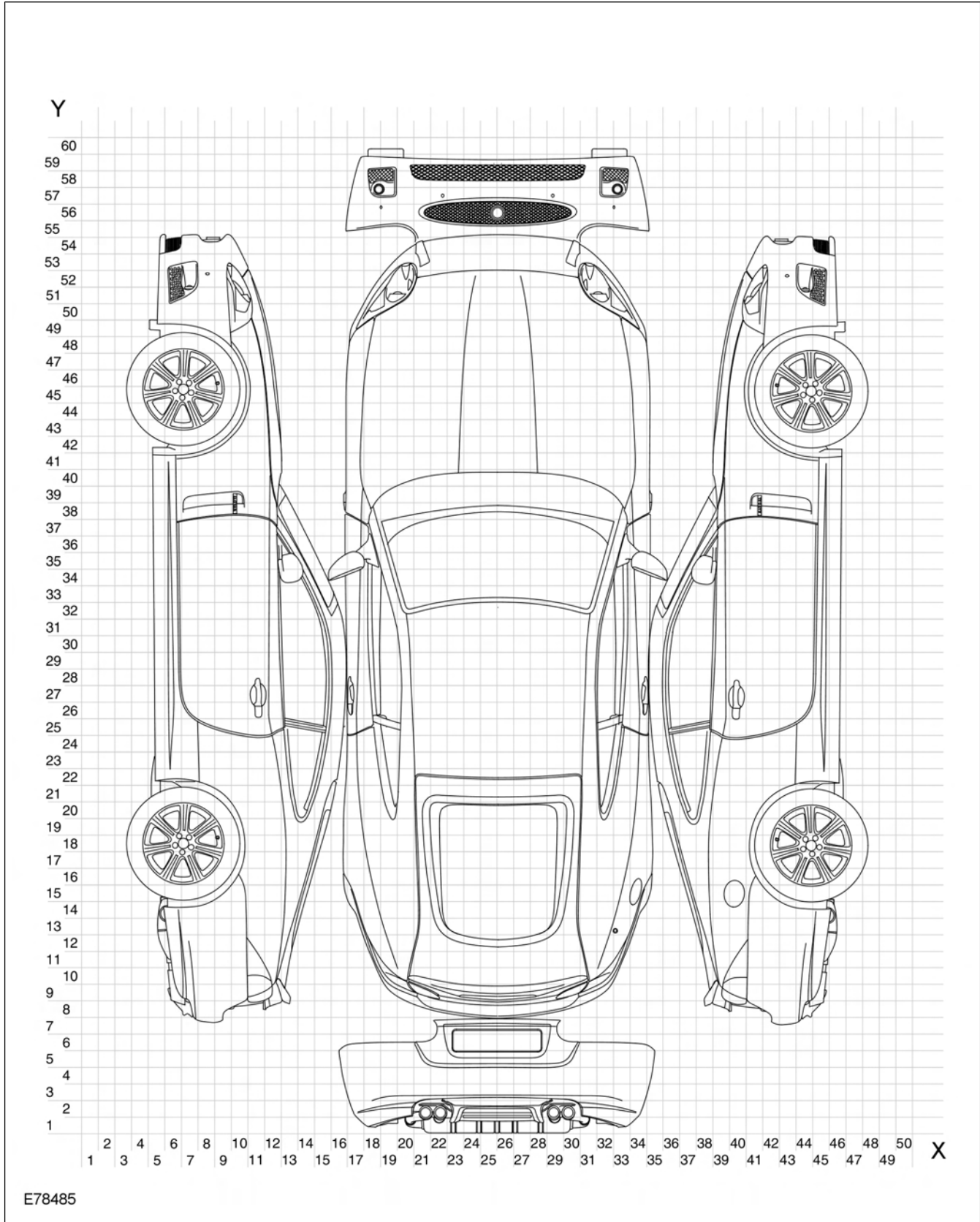

E78485

Attachment 2

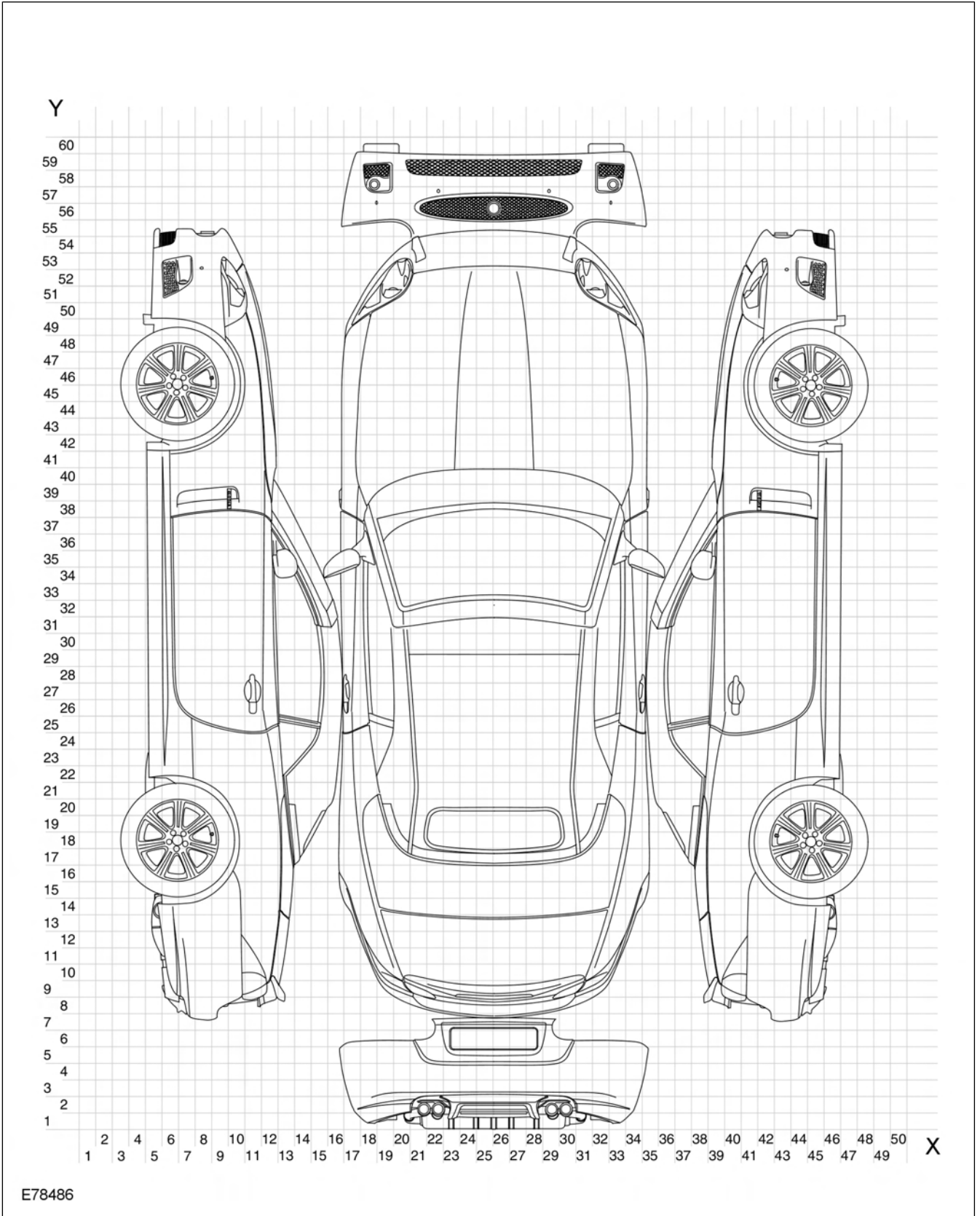

E78486



MODEL
2007 XK

DATE
20 June 2006

NUMBER
XK501-003

SERVICE

TECHNICAL BULLETIN

SECTION: 501-14

Smart Key Docking Station Cover Return Spring

AFFECTED VEHICLE RANGE:

New XK

VIN: B04704 to B04753

Model Year: 2007

CONDITION SUMMARY:

SMART KEY DOCKING STATION COVER RETURN SPRING NOT INSTALLED

Situation: This "information only" bulletin has been published to inform dealer personnel that the production vehicles in the VIN range B04704 to B04753 were built without the return spring installed in the Smart Key docking station cover. The docking station cover will need to be opened and closed manually on these vehicles.



NOTE: The lack of a return spring is not considered a fault. Components associated with this situation are not to be replaced under Warranty.

No customer complaints are anticipated regarding this issue.

Action: No action required.

PARTS:

No parts required. Information purposes only.

WARRANTY:

No warranty associated with this bulletin. This bulletin is issued for information purposes only. Normal warranty policy and procedures apply.

NOTE: The information in Technical Bulletins is intended for use by trained, professional technicians with the knowledge, tools, and equipment required to do the job properly and safely. It informs these technicians of conditions that may occur on some vehicles, or provides information that could assist in proper vehicle service. The procedures should not be performed by "do-it-yourselfers." If you are not a Retailer, do not assume that a condition described affects your vehicle. Contact an authorized Jaguar service facility to determine whether the bulletin applies to a specific vehicle.



MODEL
2007 XK

DATE
26 June 2006

NUMBER
XK501-004

SERVICE

TECHNICAL BULLETIN

SECTION: 501-00

Console Ashtray Lid Will Not Remain Open, is Slow or Noisy

AFFECTED VEHICLE RANGE:

New XK

VIN: B00001 to B03391

Model Year: 2007

CONDITION SUMMARY:

FLOOR CONSOLE ASHTRAY LID WILL NOT REMAIN OPEN, OPERATION IS SLOW OR NOISY

Situation: This bulletin has been issued to address customer concerns that the floor console ashtray lid will not remain open, or that the operation is slow or noisy.

The ashtray lid veneer may be bowing, causing the ashtray lid veneer to contact the console trim panel.

Action: Should a customer express a concern related to these symptoms, refer to the appropriate Repair Procedure detailed in this bulletin to repair or replace the floor console ashtray.

PARTS:

- C2N2605.....Ashtray assembly Qty 1 (if needed)
- JLM21204.....Squeak and Rattle Repair Kit Qty 1 (if needed)
 - JLM21205...Foam pad (included in repair kit)

WARRANTY:



NOTE: Repair procedures are under constant review, and therefore times are subject to change; those quoted here must be taken as guidance only. Always refer to DDW to obtain the latest repair time.

DDW requires the use of causal part numbers. Labor only claims must show the causal part number with a quantity of zero.

Description	SRO	Time (Hours)	Condition Code	Causal Part
Apply foam pad to ashtray lid veneer	76.95.12	0.20		C2N2605
Modify ashtray cover trim panel	76.95.13	0.20		C2N2605
Replace console ashtray	76.25.25	1.30		C2N2605

Normal warranty policy and procedures apply.

NOTE: The information in Technical Bulletins is intended for use by trained, professional technicians with the knowledge, tools, and equipment required to do the job properly and safely. It informs these technicians of conditions that may occur on some vehicles, or provides information that could assist in proper vehicle service. The procedures should not be performed by "do-it-yourselfers." If you are not a Retailer, do not assume that a condition described affects your vehicle. Contact an authorized Jaguar service facility to determine whether the bulletin applies to a specific vehicle.

REPAIR PROCEDURES



NOTE: GTR lookup sequence is as follows:

GTR Home > NAS > Service Information/ X150 -XK/2007 > Workshop Manuals > New XK – Workshop Manual > Bookmark "Body and Paint/501-12: Instrument Panel and Console" Link "Floor Console Finish Panel (76.47.26)"



CAUTION: Care must be taken to prevent damage to console trim and veneer panels.

REPAIR NOISY OR SLOW ASHTRAY LID OPERATION

1. If the ashtray lid is noisy or slow when operating, refer to GTR section 501-12 operation 76.47.26 and remove the floor console veneer panel.



CAUTION: To avoid damage to the components, the hooked screwdriver, or suitable tool, must be carefully inserted as high up the ashtray cover panel as possible when releasing the clips to remove the ashtray cover panel. (Arrowed in Figure 1)

2. Using a thin hooked screwdriver, or suitable tool, release the two clips securing the ashtray cover panel. (Arrowed in Figure 1)
3. Remove the ashtray cover panel.
4. Check operation of ashtray lid.
5. If the ashtray lid operation 'noise' has disappeared or the 'slow' operation has been resolved, modify the ashtray cover panel as follows:
 - Select a suitable fine file.
 - Lightly file along the lower edge of ashtray cover panel, removing only enough material to allow smooth operation of the ashtray lid. (Figure 2)
6. Install the ashtray cover panel.
7. Verify that the lid operates properly and no noise is present.
8. Refer to GTR Workshop Manual, section: 501-12 operation 76.47.26 and install the floor console veneer panel.

Figure 1

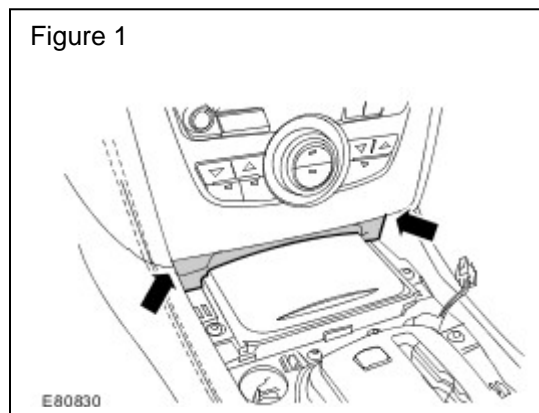
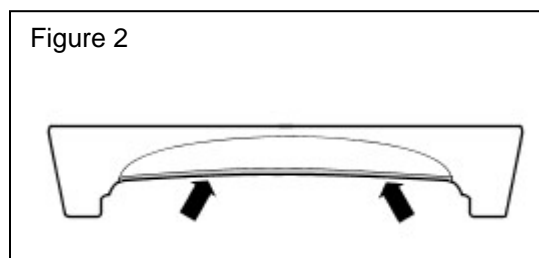

Figure 2



REPAIR ASHTRAY LID LATCHING

1. If the ashtray lid will not remain open, refer to GTR section 501-12 operation 76.47.26 and remove the floor console veneer panel.
2. Using a thin screwdriver, or suitable tool, hold the ashtray lid a quarter of the way open. (Solid arrow in Figure 3)
3. Pull the veneer towards the rear of the vehicle to release the four securing clips. (Dashed arrow in Figure 3)
4. Slide the ashtray lid veneer panel off to remove.
5. Check operation of ashtray lid.
6. If the ashtray lid latches, perform the following:
 - Cut a piece of foam pad to the dimensions 22.5 mm x 15 mm (0.9 in. x 0.6 in.) as illustrated. (Shaded in Figure 4)
 - Apply the foam pad to the back of the ashtray lid veneer between the tabs as illustrated. (Arrowed in Figure 4)
 - Slide the ashtray lid veneer panel onto the ashtray lid to install.
 - Open the ashtray lid until audible 'clicks' are heard, confirming engagement of the four veneer panel securing clips.
7. Verify proper operation of the ashtray lid.
8. If noise is heard or the operation is slow, perform the operations detailed in **REPAIR NOISY OR SLOW ASHTRAY LID OPERATION** section of this bulletin.

Figure 3

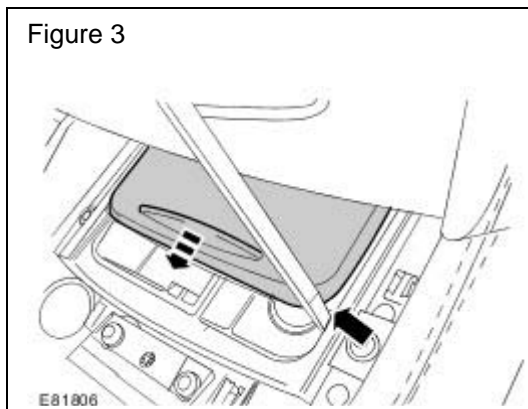
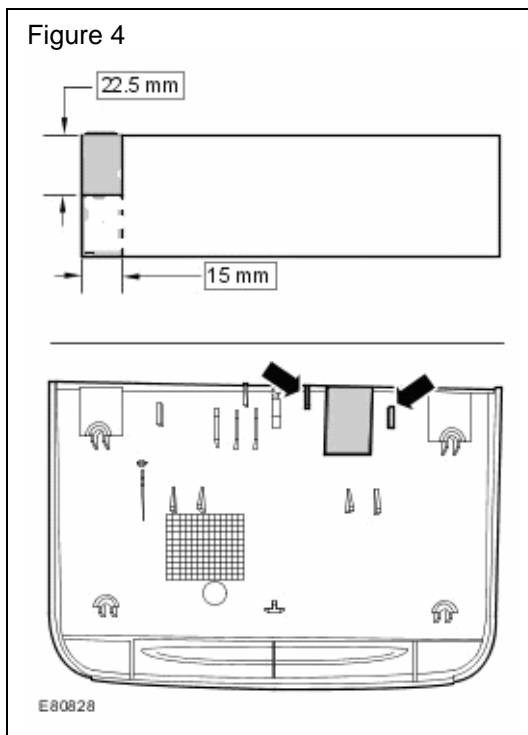

Figure 4



9. If the ashtray lid will not latch, perform the following:
 - Refer to GTR Workshop Manual section 501-12 operation 76.25.01, and remove the floor console to gain access to the ashtray securing screws.
 - Remove the ashtray securing screws and the ashtray from the floor console.
 - Verify that the ashtray lid latch is installed.
 - If the latch is not installed (**X**-marked in Figure 5), install a new ashtray assembly (C2N2605).
 - If the latch has become detached, install the latch correctly. (**✓**-marked in Figure 5)
 - If the ashtray lid still does not latch, install a new ashtray assembly (C2N2605).

10. Refer to GTR Workshop Manual, section: 501-12 operation 76.25.01 and install the floor console.

11. Verify proper operation of the ashtray lid.

