



MODEL XK
-------------

DATE 18 MAR 2009
---------------------

NUMBER JTB00031 (Issue 2)
---------------------------------

Service

TECHNICAL BULLETIN

**ISSUE '2' CHANGES ARE HIGHLIGHTED WITH GRAY BACKGROUND**

**SECTION: 419**

**Touch-screen Freezes / Changes Without User Input - Repair Procedure**

**AFFECTED VEHICLE RANGE:**

XK (X150)

**VIN:** B00001 - B20990  
**Model Year:** 2007 - 2008

**CONDITION SUMMARY:**

**Situation:** A concern where the touch-screen freezes and does not respond or that the touch-screen intermittently changes without driver input has been identified. This may be caused by the touch-screen bezel contacting the touch-screen causing a false input command.

**Action:** In the event of a customer concern of the above, refer to the Repair Procedure outlined below to adjust the touch-screen bezel.

**PARTS:**

No parts required

**TOOLS:**

Refer to Workshop Manual (GTR) for any required special tools

**WARRANTY:**

**NOTE:** Repair procedures are under constant review, and therefore times are subject to change; those quoted here must be taken as guidance only. Always refer to DDW to obtain the latest repair time.

DDW requires the use of causal part numbers. Labor only claims must show the causal part number with a quantity of zero.

Description	SRO	Time (hours)	Condition Code	Causal Part
Touch-screen bezel adjustment	76.95.27	0.40	07	C2P 15299

Normal warranty policy and procedures apply.

NOTE: The information in Technical Bulletins is intended for use by trained, professional Technicians with the knowledge, tools, and equipment required to do the job properly and safely. It informs these Technicians of conditions that may occur on some vehicles, or provides information that could assist in proper vehicle service. The procedures should not be performed by 'do-it-yourselfers'. If you are not a Dealer, do not assume that a condition described affects your vehicle. Contact an authorized Jaguar service facility to determine whether this bulletin applies to a specific vehicle.

## **REPAIR PROCEDURE**

### **TOUCHSCREEN BEZEL ADJUSTMENT**

1. Ensure the park brake is applied, select 'D', and switch the ignition 'OFF'.



**CAUTION: Protect the surrounding trim from damage. A substantial protective pad over the center console gear lever area is required.**

2. Remove the veneer trim from around the touch-screen and switches. (Figure 1)
3. Remove the four Torx T30 screws which clamp to the metal frame. (Figure 2)
4. Remove the two Torx T20 screws which hold the center vent. (Figure 2)
5. Pull the center stack assembly from the fascia. (Figure 3)
6. Loosen each of the four Torx T30 screws that hold the touch-screen into the metal frame one turn. (Figure 4)
7. Loosen each of the two Torx T20 screws that hold the touch-screen to the plastic bezel one turn. (Figure 5)

Figure 1

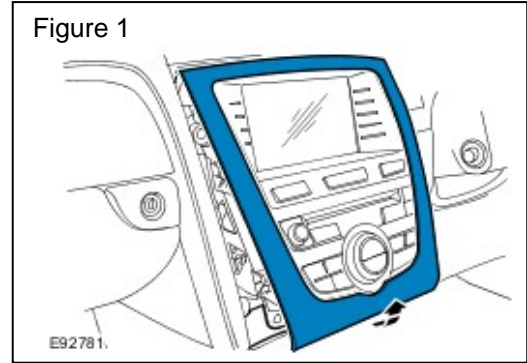

Figure 2

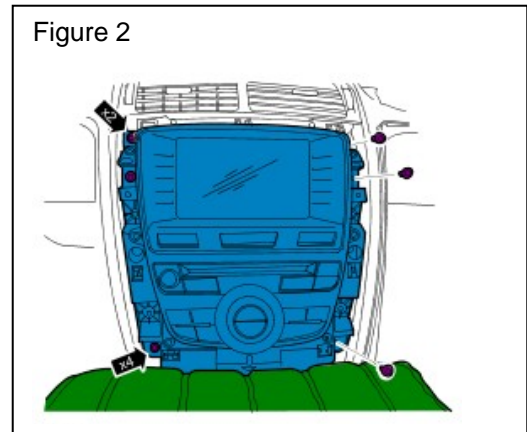

Figure 3

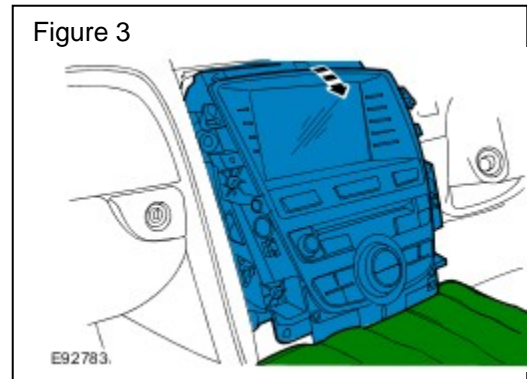

Figure 4

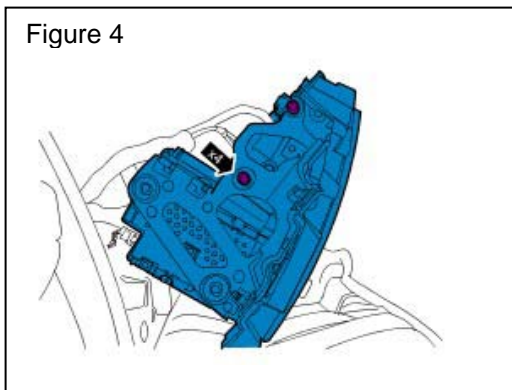
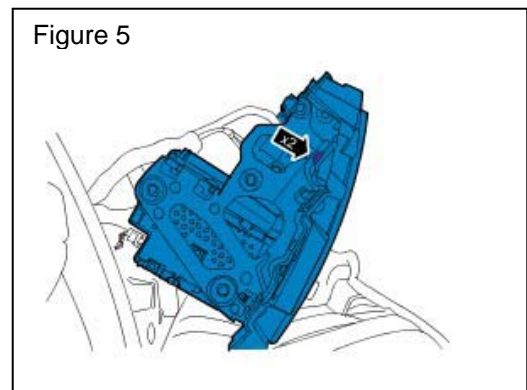

Figure 5



**NOTE:** The required gap between the screen and the bezel is 0.8mm (0.030 in)

8. Measure the gap between the screen and the bezel.
9. Applying light pressure to the screen (moving the unit rearward in the frame), tighten the four Torx T30 screws while holding the screen in position
10. Install the center stack assembly into the fascia. (Figure 6)
11. Position and tighten the four Torx T30 screws which clamp to the metal frame and the two Torx T20 screws which hold the center vent. (Figure 7)
12. Install the veneer trim.
13. Slide a twice-folded piece of paper around the gap between the screen and the bezel to check the gap between the screen and bezel. (Figure 8)
14. Switch the ignition to the 'ON' position.
15. Check operation of the touch-screen. (Figure 9)
16. Switch the ignition to the 'OFF' position.

Figure 6

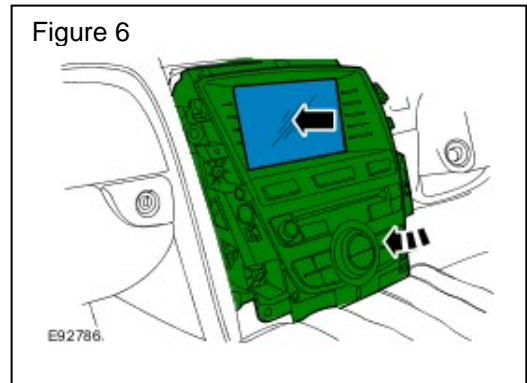

Figure 7

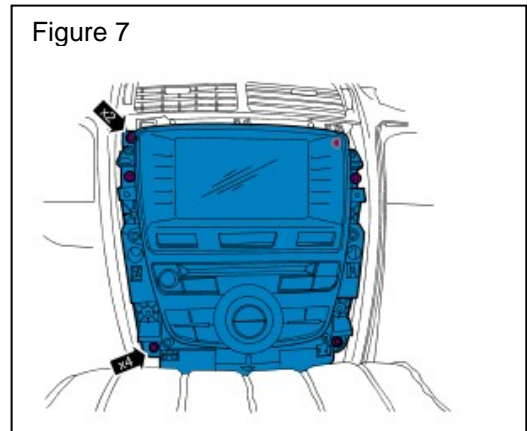

Figure 8

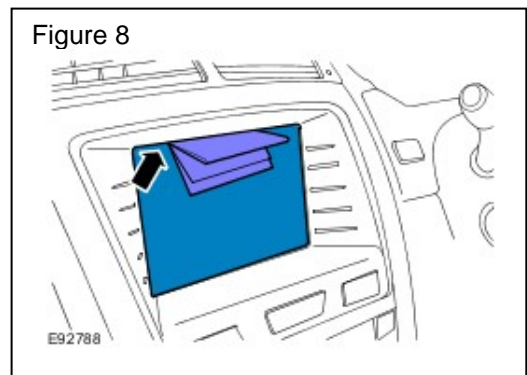

Figure 9

