

206-04 : Rear disc brake

Specifications

Specifications

Brake Disc

Item	Specification
Disc type	Ventilated
Disc diameter	326 mm (12.8 in)
Disc diameter (vehicles fitted with Alcon braking system)	350 mm (13.78 in)
Disc thickness (new)	20 mm (0.78 in)
Disc thickness (vehicles fitted with Alcon braking system new)	28 mm (1.10 in)
Minimum disc thickness (service limit)	18 mm (0.70 in)
Minimum disc thickness (vehicles fitted with Alcon braking system service limit)	26 mm (1.02 in)
Disc thickness variation (new)	0.008 mm (0.0003 in)
Maximum disc run-out - installed	0.075 mm (0.0029 in)
Maximum hub face run-out - installed	0.0135 mm (0.00053 in)

Caliper and pads

Item	Specification
Caliper	Floating aluminium caliper with 45 mm single piston and integral park brake mechanism
Caliper (vehicles fitted with Alcon braking system)	Opposed aluminium caliper with four 31.8 mm diameter pistons.
Minimum pad thickness (service limit)	2 mm (0.078 in)
Minimum pad thickness (vehicles fitted with Alcon braking system service limit including brake pad back plate)	7.5 mm (0.30 in)

Torque Specifications

Item	Nm	lb-ft
------	----	-------

Brake caliper anchor plate - bolts*	103	76
Brake caliper - guide pins	28	21
Brake hose to caliper - union	35	26

* New nuts/bolts must be installed **Torque Specifications - vehicles fitted with Alcon braking system**

NOTE:

Alcon brake system can be identified by the existence of half-moon shaped marking in the friction surface of the brake disc.

Item	Nm	lb-ft
Hydraulic brake caliper anchor plate to wheel knuckle - bolts*	108	80
Hydraulic brake caliper to caliper anchor plate - bolts	115	85
Parking brake caliper to caliper anchor plate - bolts	63	46
Parking brake caliper anchor plate to rear wheel knuckle - front bolt	70	52
Parking brake caliper anchor plate to rear wheel knuckle - rear bolt	63	46

* New nuts/bolts must be installed

Rear Disc Brake

COMPONENT LOCATION

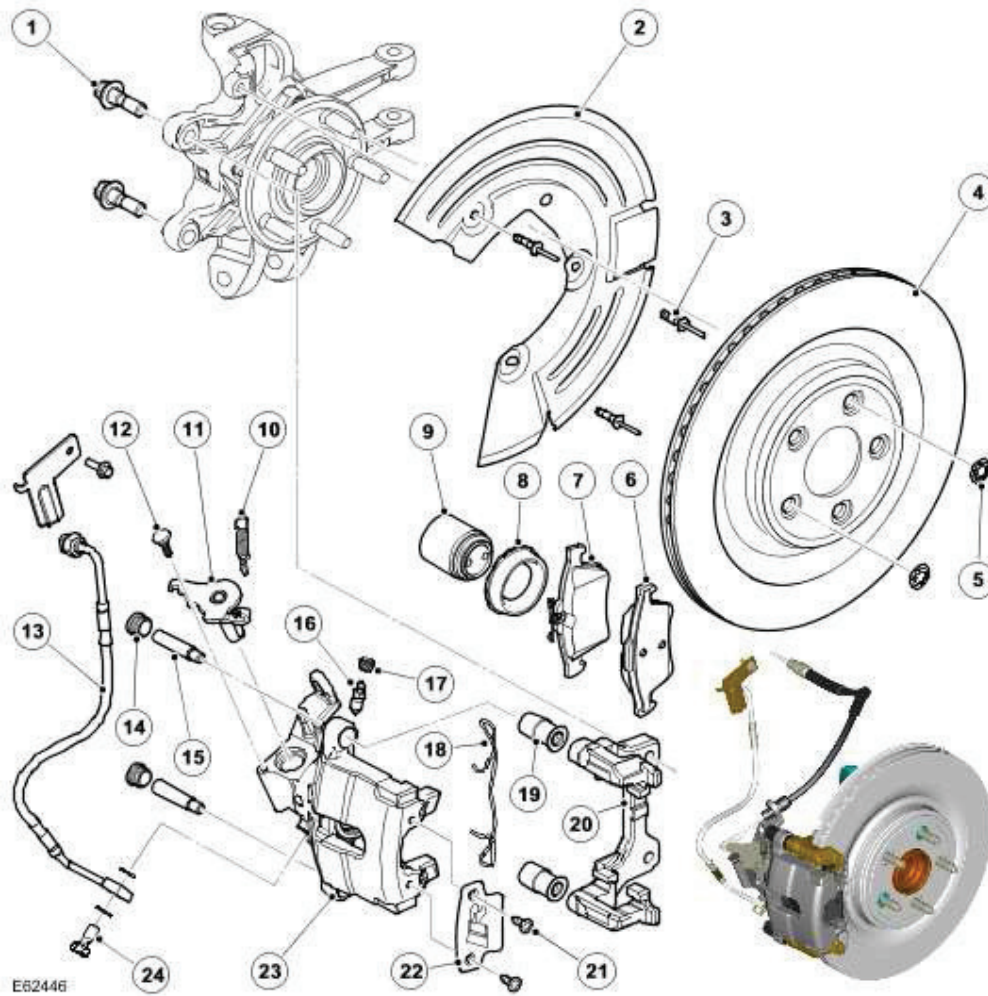

Item	Part Number	Description
1		Caliper carrier bolts (2 off)
2		Brake dust shield
3		Rivets (3 off)
4		Brake disc

5		Retaining washers (2 off)
6		Outboard brake pad
7		Inboard brake pad
8		Piston dust cover
9		Piston
10		Parking brake return spring
11		Parking brake lever
12		Parking brake lever stop
13		Brake hose
14		Guide pin dust cover (2 off)
15		Guide pins (2 off)
16		Bleed screw
17		Bleed screw dust cap
18		Anti-rattle spring
19		Guide pin bush (2 off)
20		Caliper carrier
21		Screw (2 off) - (supercharged model)
22		'R' type logo badge (supercharged model)
23		Brake caliper housing
24		Bolt - brake hose to caliper

INTRODUCTION

The rear braking system on both the naturally aspirated and supercharged vehicles features 326 x 20 mm (12.83 x 0.79 in) diameter ventilated brake discs with aluminum, single acting piston, sliding calipers.

The brake calipers on the supercharged vehicle are painted and also include a logo badge. The logo badge must be removed in order to renew the brake pads.

The caliper is mounted within a fixed carrier that is secured to the rear wheel knuckle with 2 bolts. When hydraulic pressure is supplied to the caliper, the piston extends to force the inner pad against the brake disc. The caliper reacts and slides along 2 guide pins to bring the outer pad into contact with the brake disc.

Each inboard brake pad is installed with a wire type anti-rattle spring.

NOTE:

There is no wear indicator installed to the rear brake pads.

The brake disc is manufactured from cast iron and is of the vented type. The disc is retained on the wheel hub by 2 retaining washers and the wheel nuts.

Also incorporated into each rear brake caliper carrier is the parking brake mechanism. For additional information, refer to [Parking Brake \(206-05 Parking Brake and Actuation\)](#)

Repairs



CAUTION: Do not use the 'Emergency Release' tool to allow work to be carried out on the rear brakes. Work can only be carried out on the rear brakes after the 'parking brake unjam' routine is run.

Before carrying out any work on the rear brakes, the Jaguar approved diagnostic system must be connected and the 'parking brake unjam' routine run.

When all work is carried out on the rear brakes, the parking brake system will require resetting. For additional information, refer to [Parking Brake \(206-05 Parking Brake and Actuation\)](#)

Rear Disc Brake

For additional information, refer to <<206-00>>.

Brake Caliper (70.55.03)

Special Service Tools



Brake pedal hold down tool
JDS9013

Removal

All vehicles

- 1  **WARNING: Do not work on or under a vehicle supported only by a jack. Always support the vehicle on safety stands.**

Raise and support the vehicle.

- 2 . Remove the LH rear wheel and tire.
For additional information, refer to Wheel and Tire (74.20.05)
- 3 . Release the parking brake cable tension.
For additional information, refer to Parking Brake Cable Tension Release

- 4  **CAUTION: Always plug any open connections to prevent contamination.**

NOTE:

To prevent the loss of brake fluid, using the special tool apply the brake pedal and set to 40mm (1.6 in) below the rest position.

Disconnect the brake hose from the brake caliper.

- ▶ Using the special tool, press and hold the brake pedal.
- ▶ Remove and discard the 2 sealing washers.

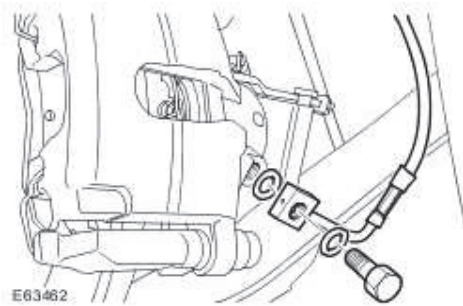

Vehicles with high performance brakes

5 . Remove the logo badge.

- ▶ Remove the 2 screws.

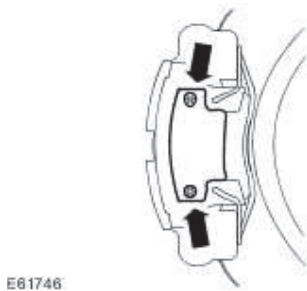

All vehicles

6 . Remove the LH anti-rattle spring.

▶ Release the 2 clips.

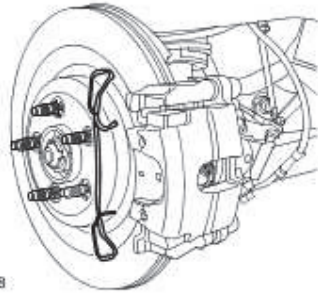

E62738

7 . Disconnect and release the parking brake cable from the caliper.

▶ Release the clip.

8 . Remove the LH brake caliper.

▶ Remove the 2 access plugs.

▶ Release the 2 brake caliper guide pins.

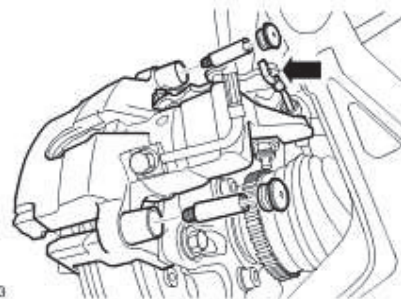

E66773

9 . Remove the brake pads.

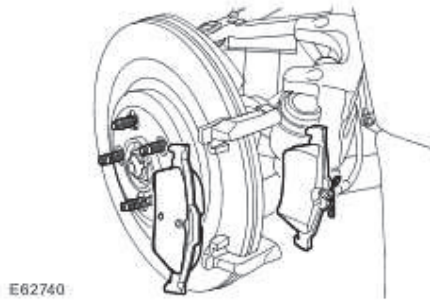

10 . **NOTE:**

Do not disassemble further if the component is removed for access only.

Remove the brake caliper anchor plate.

▶ Remove and discard the 2 bolts.



Installation

All vehicles

1 . Install the brake caliper anchor plate.

▶ Clean the component mating faces.

▶ Tighten the bolts to 103 Nm (76 lb.ft).

2 . Install the LH brake pads.

3 . Install the LH brake caliper.

 Tighten the guide pins to 28 Nm (21 lb.ft).

 Install the access plugs.

4 . Install the LH anti-rattle spring.

 Carefully secure the clips.

Vehicles with high performance brakes

5 . Install the logo badge.

 Tighten the screws to 5 Nm (3 lb.ft).

All vehicles

6 . Connect the brake hose to the brake caliper.

 Install new sealing washers.

 Tighten the union to 35 Nm (26 lb.ft).

7 . Connect the parking brake cable.

 Carefully secure the clips.

8 . Install the wheel and tire.

For additional information, refer to Wheel and Tire (74.20.05)

9 . Bleed the brake system.

For additional information, refer to Brake System Bleeding (70.25.03)

Brake Disc (70.10.11)

Removal



WARNING: Brake pads must be renewed in axle sets only. Failure to follow this instruction may result in braking efficiency being impaired.

1



- **WARNING:** Do not work on or under a vehicle supported only by a jack. Always support the vehicle on safety stands.

Raise and support the vehicle.

- 2 . Remove the rear brake pads.

For additional information, refer to Brake Pads (70.40.03)

- 3 . Tie the brake caliper aside.

- 4 . Remove the brake caliper anchor plate.

 Remove and discard the 2 bolts.

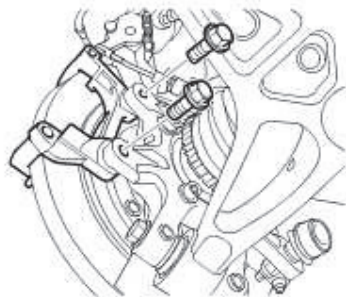

E62736

- 5 . Remove the brake disc.

- ▶ Remove the 2 clips.

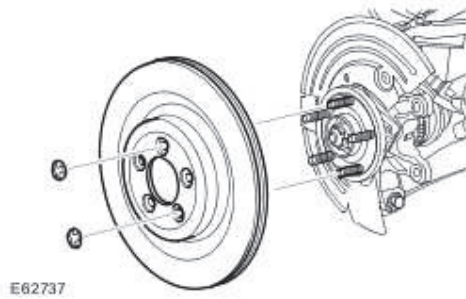

Installation

- 1 .  **WARNING: Do not use compressed air to clean brake components. Dust from friction materials can be harmful if inhaled.**

Install the brake disc.

- ▶ Clean the component mating faces.
- ▶ Secure the clips.

- 2 . Install the brake caliper anchor plate.

- ▶ Clean the component mating faces.
- ▶ Tighten the bolts to 103 Nm (76 lb.ft).

- 3 . Install the brake pads.

For additional information, refer to Brake Pads (70.40.03)

Brake Disc (70.10.11)

Removal



WARNING: Brake pads must be renewed in axle sets only. Failure to follow this instruction may result in braking efficiency being impaired.

1



- **WARNING:** Do not work on or under a vehicle supported only by a jack. Always support the vehicle on safety stands.

Raise and support the vehicle.

- 2 . Remove the rear brake pads.

For additional information, refer to Brake Pads (70.40.03)

- 3 . Tie the brake caliper aside.

- 4 . Remove the brake caliper anchor plate.

 Remove and discard the 2 bolts.

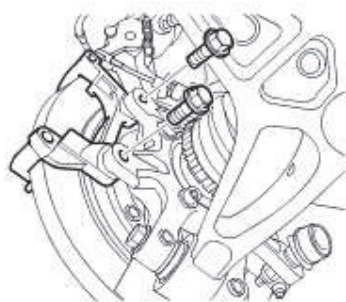

- 5 . Remove the brake disc.

- ▶ Remove the 2 clips.

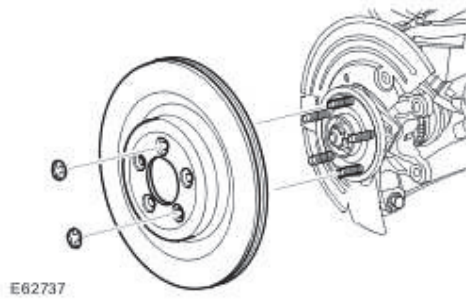

Installation

- 1 .  **WARNING: Do not use compressed air to clean brake components. Dust from friction materials can be harmful if inhaled.**

Install the brake disc.

- ▶ Clean the component mating faces.
- ▶ Secure the clips.

- 2 . Install the brake caliper anchor plate.

- ▶ Clean the component mating faces.
- ▶ Tighten the bolts to 103 Nm (76 lb.ft).

- 3 . Install the brake pads.

For additional information, refer to Brake Pads (70.40.03)

206-05 : Parking brake and Actuation

Specifications

Specifications

Torque Specifications

Item	Nm	lb-ft	lb-in
Parking brake actuator - bolts	20	15	-
Parking brake module - nuts	4	3	35
Parking brake switch- bolts	6	4	53

Parking Brake Cable Tension Release

Special Service Tools



Electric parking brake release tool 206-082. Only to be used for EMERGENCY brake release



Electric parking brake release tool link lead 206-082-01. Only to be used for EMERGENCY brake release



WARNING: Failure to release the tension and calibrate the electric parking brake during rear parking brake related service procedures, could cause the parking brake to function incorrectly or become inoperative.



CAUTION: Ensure the vehicle transmission is in park position before the cable tension is released.



CAUTION: The warranty of the electric parking brake release tool will be invalidated if the casing has been removed.

NOTE:

The tools shown must only be used in the event of an emergency.

1.



WARNING: Always use Jaguar approved diagnostic equipment to release the cable tension, when carrying out repair operations on the electric park brake which require cable tension release.

Connect the Jaguar approved diagnostic equipment to release the electric parking brake cable tension.

- Follow the on-screen instructions.

2.



WARNING: The procedure below should only be used in emergency situations, to release the electric park brake. All calibration of the parking brake system will be lost, and the parking brake will need to be re-calibrated to function correctly.

Release the auxiliary junction box access cover.

- Release from the clip.

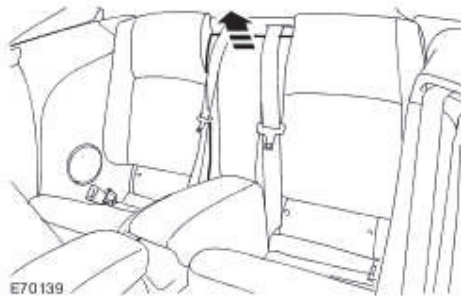

3. Disconnect the parking brake module.

- Disconnect the 2 electrical connectors in the sequence illustrated.



4. Connect the special tool.

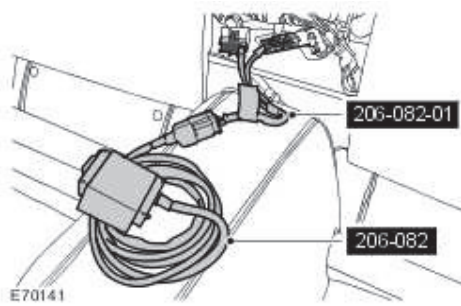

5. Release the parking brake cable tension.

- An audible 'click', signals complete parking brake cable tension release.

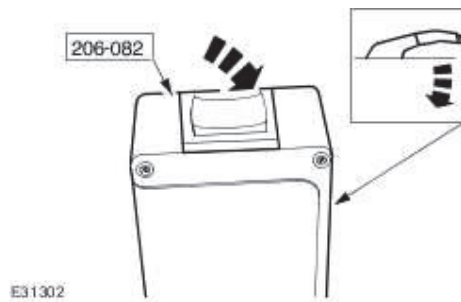

6. Remove the special tool.

- Reverse the removal sequence, connect and secure the electrical connectors.

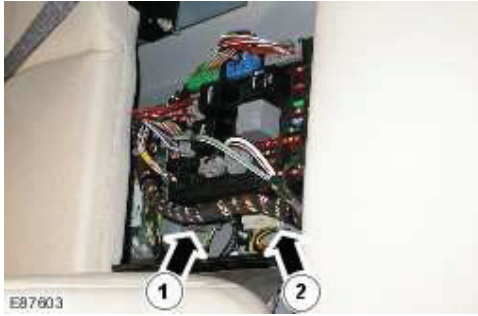

7. Secure the auxiliary junction box access cover.

- Align the pegs and secure the clip.

8.



WARNING: Calibrate the electric park brake using Jaguar approved diagnostic equipment. If Jaguar approved diagnostic equipment is not available disconnect the battery for approximately 30 seconds , the vehicle will then prompt the driver to carry out the calibration procedure as per the vehicle hand book on re-connection.

Re-calibrate the electric park brake.

Parking Brake

Principle of Operation

For a detailed description of the Parking Brake operation, refer to the relevant Description and Operation section of the workshop manual.

Parking Brake

Parking Brake Calibration

The parking brake system must be calibrated whenever the battery has been disconnected or has been in a state of discharge, or repairs have been carried out to the rear service or parking brake system.

NOTE:

If new rear brake pads have been installed, pressure must be applied to the brake pedal a minimum of five times prior to calibration of the parking brake system.

To calibrate the parking brake system:

- 1 . Place gear selector lever in 'P' Park position.
- 2 . Release parking brake cable tension to service position.
Parking Brake Cable Tension Release
- 3 . Set the ignition status to 'ON'.
- 4 . Apply and hold the footbrake then pull up the parking brake switch.
- 5 . To release the parking brake, apply and hold the footbrake then release and press down the parking brake switch.

Inspection and Verification

- 1 . Verify the customer concern.
- 2 . Visually inspect for obvious signs of damage and system integrity.

Mechanical	Electrical
<ul style="list-style-type: none">• Parking brake cable• Parking brake actuator• Brake caliper	<ul style="list-style-type: none">• Fuse(s)• Wiring harness/electrical connectors• Check for bent/corroded pins

- | | |
|--|---|
| <ul style="list-style-type: none">• Brake pads• Stabilizer bar drop link caps | <ul style="list-style-type: none">• Parking brake switch• Parking brake module |
|--|---|

3 . If an obvious cause for an observed or reported concern is found, correct the cause (if possible) before proceeding to the next step.

4 . If the cause is not visually evident check the system for any logged Diagnostic Trouble Codes (DTCs) and proceed to the DTC Index , alternatively, verify the customer concern and refer to the Symptom Chart.

DTC Index



CAUTION: When probing connectors to take measurements in the course of the pinpoint tests, use the adaptor kit, part number 3548-1358-00.

NOTE:

If the control module is suspect and the vehicle remains under manufacturer warranty, refer to the Warranty Policy and Procedures manual (section B1.2), or determine if any prior approval programme is in operation, prior to the installation of a new module.

NOTE:

Generic scan tools may not read the codes listed, or may read only five digit codes. Match the five digits from the scan tool to the first five digits of the seven digit code listed to identify the fault (the last two digits give additional information read by the manufacturer approved diagnostic system).

NOTE:

When performing voltage or resistance tests, always use a digital multimeter (DMM) accurate to three decimal places, and with an up-to-date calibration certificate. When testing resistance always take the resistance of the DMM leads into account.

NOTE:

Check and rectify basic faults before beginning diagnostic routines involving pinpoint tests.

NOTE: