

## The 2003-2005 Jaguar XK8 Convertible

Some content for this article has been blatantly ripped-off from various internet sources, some with attribution, some without, and I apologize for this in advance. If you are looking for a full service manual, the XK8 Workshop Manual .pdf on CD is available from JagDocs.com. If you are lucky enough to own one of these fine cars, you should get accurate electrical diagrams for your model year, acquaint yourself with all SBs, assess whether they apply to your particular vehicle and participate in Jaguar Forum discussions. Many routine maintenance items are relatively easy DIY tasks. Others require specialized knowledge, proprietary tools and/or a lift. My particular XK8 is a NA model (Left Hand Drive). Substantial revisions were made from the 1996MY launch thru the final 2005MY of the XK8 and occasionally documentation, even that coming directly from Jaguar, is in error regarding which parts are installed on which model year vehicles. This has led to mistakes in aftermarket part supplier listings, requiring you to be extra vigilant when sourcing replacement parts. The numbers listed herein reflect my 2005MY vehicle (YMMV).

By Gary R VanRemortel [vanremog@aol.com](mailto:vanremog@aol.com)

Revision C dated 01/04/14



**Engine Type:** DOHC aluminum alloy 32-valve 90° V8 4.2L (4196cc [256 in<sup>3</sup>])

**Avg Fuel Economy:** 22 mpg

**Bore/Stroke:** 86mm / 90.3mm

**Warm Idle:** 650 rpm

**Max Power/Torque:** 294 hp SAE @ 6000 rpm / 303 lb-ft SAE @ 4100 rpm

**BMEP:** 12.35 Bar (181.5 psig) Max, 10 Bar (147 psig) at 1500 rpm

**Wheelbase/Width/Track/Length/Height:** 101.9" / 70.8" / 59" / 188" / 51"

**Minimum Turning Radius:** 18.1 ft

**Max Speed (Ignition limited):** 155 mph

**Acceleration (0 to 60 mph):** 6.3 sec

**Curb/Gross Weight:** 3980 lb / 4808 lb

**Coefficient of Drag:** 0.36

**Spark Plugs/Gap/Torque:** NGK IFR5N-10 Iridium / .046" ± .006" / 20 lb-ft

**Coolant/DI Water 50/50:** ~10 qt WSS M97B44-D -34 to 265°F (Dexcool OAT Red/Orange)

**Fuel Capacity/Type/Rail Pressure:** 19.9 gal / 91 octane unleaded gasoline / 56 psig

**Oil Circulation Volume @ Max Pressure:** ~10 gpm @ 68 psig

**Differential Fluid:** 2 qt 75W-90 Redline Synthetic

**Power Steering and Soft Top Hydraulic Fluid:** Pentosin CHF11S

**Brakes Front/Rear:** 325 X 28mm vented slotted and drilled disc / 305 X 20mm vented disc

**Brake Fluid:** Super Blue Racing DOT4

**Battery:** AC Delco 49PS 90Ah

**Alternator:** W0133-1956598 150A w/S6 Pulley

**Wheels Front/Rear:** Keystone ALY59794U85 (19" X 8") / ALY59795U85 (19" X 9") Chrome Atlas

**Tires Front/Rear:** Michelin Pilot Super Sport P245/40ZR19 (32 psig) / P255/40ZR19 (34psig)

**Lug Nut Bolt Circle/Thread/Torque:** 5 Lugs on 4.75" [120.65mm] centers / ½"-20 / 75 lb-ft

## Overview

Enthusiasts describe the XK8 as having poise, grace and refined power. The stretched bonnet, boot proportions and large oval grille opening evoke familiar classic features of the legendary XKE. The car has a look that is both muscular and voluptuous at the same time, due to its length, large wheels and convex panels. Tear-drop eye shaped lighting fixtures enhance its distinctive cat-like aura. The original door rub strips from the '90s are gone, leaving a clean smooth look, so be sure to park yours well away from potential door bangers.

High-strength steel members throughout assure a rigid body structure, while crumple zones at the front and rear corners absorb forces in a crash. There are two triangulating braces running from the top of the firewall to the strut towers. Convertibles benefit from additional cross-bracing under the engine bay, stiffening members in the door sills and a reinforced windshield frame, helping to compensate for the lack of a roof structure and significantly reducing scuttle shake. From its basic structure through to its sophisticated electronic control systems and safety provisions, Jaguar engineers designed the XK8 to deliver intelligent innovation and they achieved a fine example of drivable art.

The XK8 body is entirely new, but the floor-pan is modified from the XJS. The body-in-white is both stiffer and lighter than the XJS. Torsional stiffness is improved by 25% and the body structure consists of 30% fewer panels. Special high-strength steels form the panels subject to the highest loads (approximately 15% of the body), including the front longitudinals, seat-belt anchors, suspension mounting points, bumper mounts and the side-impact beams within each door.

Convertible owners will certainly experience all the pleasures of top-down motoring -- with the convenience of one-button operation and automatic latching -- yet they will also be treated to cabin refinement on par with many luxury coupes. The quiet, draft-free interior is the result of several factors: a world-class sealing system, a fully lined and padded soft top, a 5mm thick heated glass rear window and a painstaking attention to detail by design house Karmann of Germany, who shared in the body development work.

The Jaguar XK8 is all car. It epitomizes agility, balance, comfort and convenience. The XK8 is not a race ready sports car like the XKE. In contrast to the aggressive masculine character of the Chevrolet Corvette, the XK8 instead exudes a powerful feline beauty, offers opulent sport luxury appointments and surrounds the occupants with rich wood and leather refinements. It is arguably one of the most beautiful automobiles in the world.

Being a mechanical engineer, I believe that a fine GT car like the Jaguar XK8 is as near to a living machine as we are likely to have for a while. It is not just basic transportation, but it can be a superb daily driver. I strongly encourage XK8 owners to take a personal interest in learning about their car's systems, care about their ongoing condition and see to their periodic needs. These cars are very well designed, have matured well over the 10 years they were offered, and I feel that each owner will want to keep it in as good a condition as possible, for as long as possible. Be aware that repair shops may have policies against installing non-Jaguar branded replacement parts, so you may be on your own when installing aftermarket parts. Maintenance technicians are not engineers, are not equipped to render a judgment on the quality of your alien parts and they don't want you suing them if something goes wrong with your car as a result. You should respect this mindset.

Several weaknesses in the original design have been addressed in the 4.2L equipped cars, but there are additional items of which you should be aware, so following are my opinions/observations on the car's systems. If you believe that an important issue has been overlooked or an error made, please contact me directly.

## Engine

The Jaguar designed AJ34 4.2L closed deck (no valley pan, just a plug) conventionally aspirated V8 engine has 5 main bearings and is both compact, lightweight (441 lb) and strong running all the way to its 6400 rpm redline. Unlike its famous V12 predecessor however, its torque curve rolls off quite a bit below 2000 rpm, but this tradeoff returns good mileage at freeway speeds. As shown in the line drawing below, the bedplate mates to the cylinder block and the bottom structural oil sump mates to the bedplate, providing exceptional rigidity, durability and smoothness. In the Cosworth designed cylinder heads, variable intake cam phasing (VVT) provides responsiveness with good fuel economy across a wide range of driving conditions. The Krebsoge sinter-forged steel con-rods are fracture split at the crank end.

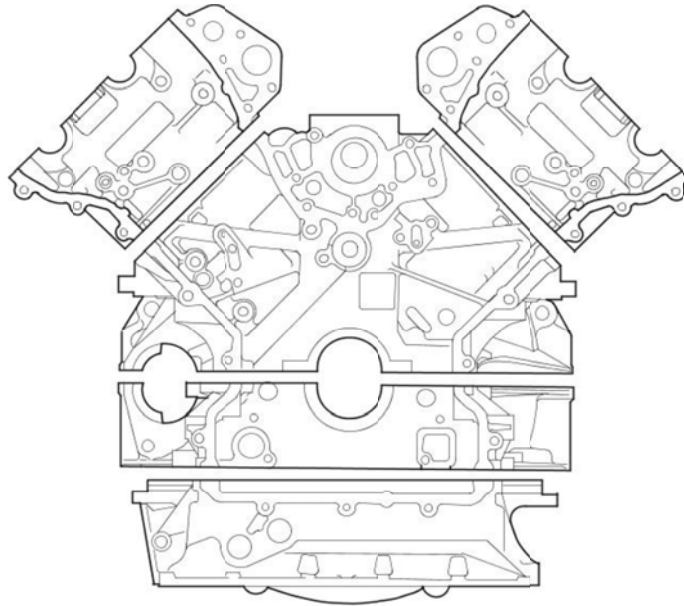

E31285

At the 1996MY launch, the AJ27 4.0L incarnation of this engine assumed class leadership in weight, stiffness, low friction, specific power output and efficiency. The engine was claimed to require no maintenance other than fluid and filter changes for 100K mi. We find this claim to be wishful thinking, but the few things that do tend to go wrong in the newer AJ34 are relatively easy DIY endeavors. Attention to these concerns will ensure that you get good service from this fine engine. The early 4.0L engines suffered from eroding Nikasil cylinder plating (due to the high sulfur in fuel at the time, combined with excess moisture brought on by short trips) but this was dealt with early on. The 4.2L engines all have iron bores and I have attempted to construct an output graph of the AJ34 below. BSFC of this very efficient engine is around .40 lb/hp/hr.

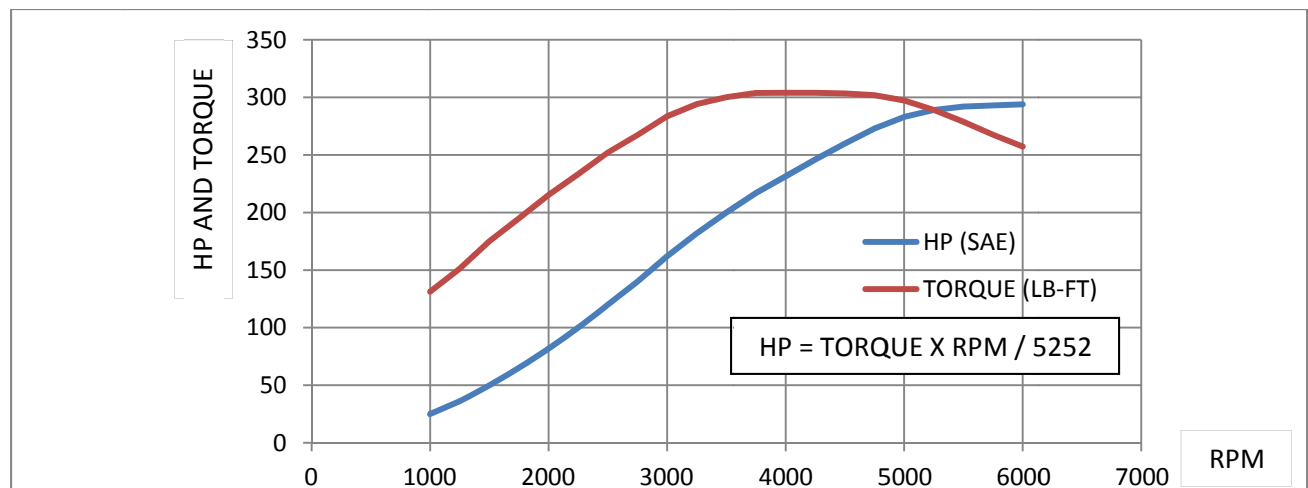



## Valvetrain

The AJ34 4.2L engine introduced in the XK8 2003MY, uses tougher Morse chains (rather than the original simplex) and has aluminum cased (rather than the original plastic) cam chain tensioners. These more robust components better handle the torsional load reversals that occur in the intake cams. The now wider Variable Valve Timing (VVT) rotates the cam up to  $48^\circ$  within 0.7 sec. The supercharged version of this engine doesn't have VVT, so it is easier on the chains and tensioners. Gun drilled camshafts, shimmed for life inverted bucket lifters and light (5mm dia) valve stems reduce the valve train mass and cam loads as much as possible. The intake and exhaust valve axes are  $28^\circ$  apart, forming near ideal combustion chamber geometry for this 11:1 compression ratio engine and valve lift is 9mm. Jaguar specifies the use of Premium unleaded fuel.



## Ignition

Ignition is via a NipponDenso 32-Bit electronic management system. An individual coil pack sits atop each spark plug. Bank 1 (passenger side) cylinder designations front to back are 1, 3, 5 and 7, Bank 2 are 2, 4, 6 and 8. Firing order is 1-2-7-3-4-5-6-8. Spark plugs can last for 100K mi without fouling in modern computer controlled engines running unleaded fuel, but I still recommend changing them every 50K mi. Sharper electrode surfaces of new plugs create a more robust spark, producing a more complete fuel charge burn, thereby improving mileage and in the end probably justifying the cost and effort. This ignition system is very strong and there is an SB suggesting that plugs be gapped as wide as .052" [1.3 mm]. I've kept mine set the way they are right out of the box (around .040" [1 mm]), but I'm going to gap the next set at .048" [1.2 mm] to see the results.

## Lubrication

The Jaguar AJ34 engine requires 8 qt of the finest Synthetic 5W-30 or 5W-40 oil you can get your hands on. I use Pennzoil Ultra (bought in 5 qt jugs online from Walmart for \$28, buy two and you get free shipping), but the Euro stuff is also great. You should establish regular oil/filter service at 5K to 7.5K mi intervals, any other practice being false economy. The oil filters I recommend are Mahle OC 602 and Mann W 719/7 (both ~\$13 from Rock Auto). I feel that the cheapest oil filters having common paper media are a waste of money and are virtually useless at trapping combustion by-products (mostly carbon) that get into the oil. Cast iron sleeves allow a bit more oil loss than do Nikasil lined bores. I installed the Fumoto F-106 (M14-1.5 thread w/o nipple) oil drain valve to make my regular oil changes easier. Never let the oil level get low -- if the low oil light comes ON, you're on borrowed time. If the car is parked facing downhill, I have noticed a tendency during cold starts for slight valve noise lasting just a split second. It probably has something to do with how the thin oil drains out of the heads and galleries when cold. On flat ground or facing uphill it starts quietly.

## Cooling System

The engine has a split flow, low volume, high flow cooling system allowing the engine to reach operating temperature very quickly (<4 minutes), contributing to ready drivability, low emissions and good fuel economy. In our opinion Jaguar really should have incorporated a more substantial thermal blanket with a high R factor instead of the light aluminum heat shields separating the back of the engine, catalysts and center muffler from the cabin. The waste heat from the engine makes the cabin cozy in the winter, but makes use of the A/C mandatory in ambient temperatures above 80°C when the top is up.

The coolant used is modern Organic Acid Technology (OAT) ethylene glycol (Dexcool colored Red/Orange meeting WSS M97B44-D) and it is **incompatible** with other non-OAT mixtures (they combine to form an insoluble gel). The additive package in all coolant depletes slowly over heat cycles, so change it out every 30K mi or 3 yrs, whichever comes first. Pressure testing the cooling system at ~50K mi intervals is always a good idea. Pressure flushing and flow checking should be done at 100K mi with a new radiator being due somewhere between 100K and 150K mi. The plastic coolant expansion tank W0133-1657480 is a robust part but the puny internal magnetic float level sender is pretty much toast by 75K mi. I don't know if you can replace the float sender separately so I bought the whole thing with cap for around \$140. This expansion tank has two angled forward nipples, but only the front one is drilled thru. This second closed off nipple is an artifact from the older engines.

Original 4.0L coolant pumps had Black Nylon 6/6 impellers that degraded in short order, leading to overheated engines. Impellers were changed first to black PolyPhenylene Sulfide (PPS) and then finally to white PPS. All of the 4.2L engines have the improved pumps, but plastic impellers have been known to spin on their shafts. Aluminum impeller equipped equivalent pumps W133-1609249 (also Bosch 96181) are readily available. Allegations that the aluminum impeller equipped coolant pumps cavitate more than do the plastic ones cannot be confirmed. These pumps are well made, last for ~100K mi, should be supplied with a metal composite gasket and are an easy DIY installation. Three tabs in the gasket center fold up into the corresponding recesses around the outside of the

pump throat. Unfortunately the gaskets don't seem quite as good as the pumps. Visually check for coolant seepage at the sealed bearings, evident by coolant seeping out of the weep hole on the underside of the housing halfway between the rear bearing and the front bearing. Check for gasket failure, evident by a greasy looking dirt buildup on the engine block right under the pump (because boiled out glycol becomes sticky). A vestigial o-ring shown between the gasket and the engine block in some of the literature is no longer needed, but doesn't hurt. Notice the gasket sealing area degradation in the photo below. Proper torquing of the pump attachment bolts is critical to a good installation. Change the serpentine belt and the thermostat at the same time as the pump. For some reason Jaguar recommends replacing the three pump pulley bolts (item 5 in the drawing), when they are really not stressed much in this installation (the center boss carries the entire side load). Then they add insult to injury by pricing them outrageously. I reused them.

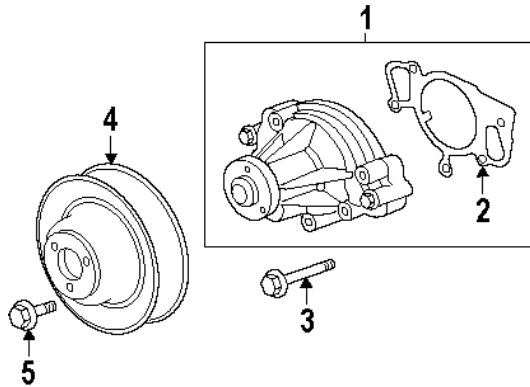

The correct 4.2L non-S/C thermostat is W0133-1655931 or AJ82697. It is quite different than that used on the earlier 4.0L engines, as is the plastic plumbing tower assy in which it mounts. There is an aluminum version of the thermostat cover-housing AJ89484 in the aftermarket supply chain, the thermostat mounting method being the same. There is also a blocked off lower nipple on this housing that suggests that it is an artifact of another version. The plastic parts are superior to the earlier phenolic parts used on the 4.0L engines but, because they are still plastic, they should be inspected closely to ensure that they are in good condition for continued use. The installation of the four piece thermostat is a little confusing for the first timer and some have installed them backwards. The correct arrangement is shown below in the left photo and its installation is best done wearing gloves. The right facing pin fits into a hole in the housing, then install the springs in/on the cap. Then compress the cap bracket against the springs until the two bent tangs can be rotated into their retention slots in the housing. There is no jiggle pin in this thermostat, so its rotational orientation in the housing is not an issue. There is a robust black elastomeric perimeter seal AJ83525 in a slot in the thermostat tower assembly that should be replaced as long as you have the thermostat housing off.



The coolant level should never be allowed to get low in the expansion tank, and if the low coolant light ever comes ON, it's likely too late. The use of a 15 psi valve expansion tank cap MJA4440BA at the very top of the system combined with an atmospheric recovery tank located low in the right front wheelwell is a great setup, because whatever blows out of the expansion tank cap valve during hot operation theoretically gets returned to the system as it cools down. Make sure that the system is really doing its job by keeping the atmospheric recovery tank at least  $\frac{1}{4}$  full of coolant, otherwise the tubing "straw" can unport (suck wind) and fail to return coolant to the pressurized portion of the system as it cools. It is difficult to assess the state of fill in the atmospheric recovery tank, as it is out of sight, out of mind and inaccessible for easy filling. You can pull the side marker light out and use a penlight for a quick visual check.

The OEM coolant hoses (particular the two going to the radiator) flow well but are relatively thin wall, making them prone to heat softening, cut-thru and blow-off/out. The inexpensive OEM "constant tension" spring steel hose clamps used are fast to install (with the right tool), compact and allow for expansion/contraction of the plastic hose nipples and compression set of the rubber hoses during heat cycles. But IMO they are a less than optimum choice for the critical task they perform, that being preventing the engine from melting into a blob. They should be replaced well before reaching 100K mi, along with the hoses they retain. I don't know whether they are just badly made of cheap mild steel or they have missed the critical heat treating steps that would assure their long term spring characteristics. I prefer the stainless steel worm-screw clamps that contact the hose for a full 360° and have a stack of multiple opposing Belleville washer pairs on the tightening screw shank providing a constant tension feature. You can get these from most good auto parts outlets and McMaster-Carr. I also prefer more robust aftermarket hoses having a greater wall thickness. Be aware that all screw type clamps need to be properly tightened. Compression set is a characteristic of elastomers and is expressed as a percentage. Therefore the thicker the hose wall, the greater the total compression set that will occur over the next few months of heat cycles, so check the clamps when cold to ensure that they are still tight on their nipples. Compression set changes the hose outside circumferential dimension and most clamps can't compensate for this great of a change. For most 1" ID and smaller cooling applications calling for straight or gently curving hose, I prefer the fiber reinforced silicone type often used on Police cars. I have used HPS, Verocious and Silicone Intakes hose firewall forward with good results on both cars and airplanes.

There is a hard plastic burp line running from a right angle nipple atop the thermostat tower assy to the side nipple on the expansion tank. It is captured in between the plastic engine cover and the intake manifold, so it sees substantial heat. I've had similar items overheat and shatter on BMWs, so mine is now a length of 5/16" [8mm] ID reinforced silicone hose from Z1 Motorsports.

The radiator drain-plug JLM20622 (Dorman 61138 is identical for about half the Jag price) is located at the bottom of the right radiator end cap facing aft and is a bit fiddly, having a hard pipe partially in the way, preventing a straight shot at tightening it with your screwdriver. It has a rubber seal under the head and barbs on the end to retain it in the port when unscrewed. It is molded black polyethylene with M10-1.5 threads, so be careful not to over tighten it or you may develop slow seepage that might not show up on the ground.

There are two rather fiddly square head attachment fasteners that retain the top of the fan assy against the radiator. With their hex nuts removed, they are free to pop out, drop down into the structures below and/or get lost. It would be wise to wedge some foam or double stick tape in between the fastener heads and their slots to keep them in place when removing the fan assy.

## **Serpentine Belt**

The 4.2L conventionally aspirated engine in the 2003-2005 XK8 uses a six rib 91" serpentine belt, Dayco 6PK2310 or equivalent and it generally lasts for somewhere between 50K and 100K mi (or about 5 yrs). The tension on the belt is released using a 3/8" square drive breaker bar with a short piece of pipe to extend the handle. There isn't much room between the tensioner recess and the left side fan hub. The belt tensioner (T) and idler pulley (G) are probably good for 150K mi or more.

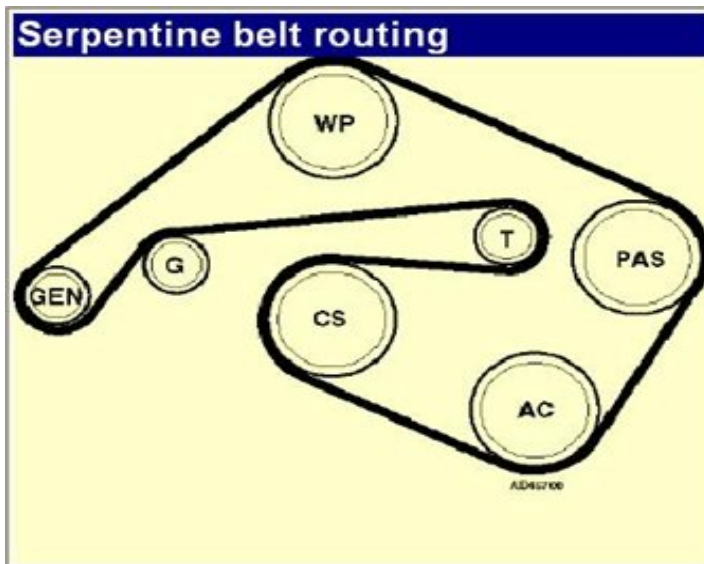

## Induction/Intake System

The induction system in the XK8 begins with a scoop in the right fender well feeding directly into the filter box, thru a short coupler that incorporates the MAF sensor mount, then into a 21" long plastic induction pipe W0133-1657567, having a 4" bellows section and two right angle turns on the way to the rear mounted throttle body. There isn't much clearance in the engine bay so, as the bonnet liner/insulator blanket sags in its mounting clips over time, it can brush lightly against the crests of the bellows section of the induction pipe if it's not fully seated. There is a small amount of relative motion between the bonnet liner and the induction pipe. It doesn't actually move very much, but it does so thousands of times per minute and the liner, being quite abrasive, slowly sands its way thru the crests of the plastic bellows. You should watch for this.

I remain unconvinced that reusable filters like the K&N 33-2190 are superior to the disposable paper elements, but there are several aftermarket Cold Air Intake kits that may prove to be slight improvements over the OEM design.



If your air filter is working well, you will only need to clean your MAF sensor every 100K mi or so using a commercial MAF sensor cleaning solvent. The MAF sensor can be unplugged and removed from the intake pipe for easy cleaning access.



## Fuel System

The fuel tank sits between the rear seat back and the boot. Beginning with the 2003MY, a return-less system was introduced. A new plastic jacketed vane pump C2N1146 with integral float sender and particulate filter sock sits in the tank. All submerged fuel pumps rely on the fuel in the tank for effective cooling, so don't make a habit of running the tank near empty. Conversely do not overfill the tank or you may foul the vapor canister system resting in the driver's side front wheelwell behind the plastic liner. The advantages claimed for return-less systems are primarily lower vapor loss, as hot fuel in the injector rail is not returned to the tank, fuel line routing is simpler, there are fewer opportunities for leaks and the reduction in circulated volume means a somewhat extended fuel filter life. The Fuel Pump Module (FPM) is able to run the pump at higher pressures (nominally ~56 psi) compared to the previous return type system, so theoretically it can better fight vapor lock. Any time you shut down a highly heat soaked engine and start it up again before it has had sufficient time to cool, vapor could have already formed in the rail. Winter blend or fuels of poor quality may have some influence on this tendency. All of that heat energy that used to get carried into the fuel tank in a return line system now just gets to boil the light ends of trapped gasoline in the rail at startup. I really wish that Jaguar would have done a better job of insulating the fuel rail from the hot engine block. All fuel systems have advantages and disadvantages, so just be advised of this particular system's characteristics. If you get a lazy fuel injector, your engine will start and idle poorly until the fuel flow stabilizes. A scan tool may show DTCs P0301 thru P0308, and the second time it happens, you might get a Check Engine Light (MIL) and DTC P0316. It probably also means it's time to send the injectors out for cleaning and flow balancing.

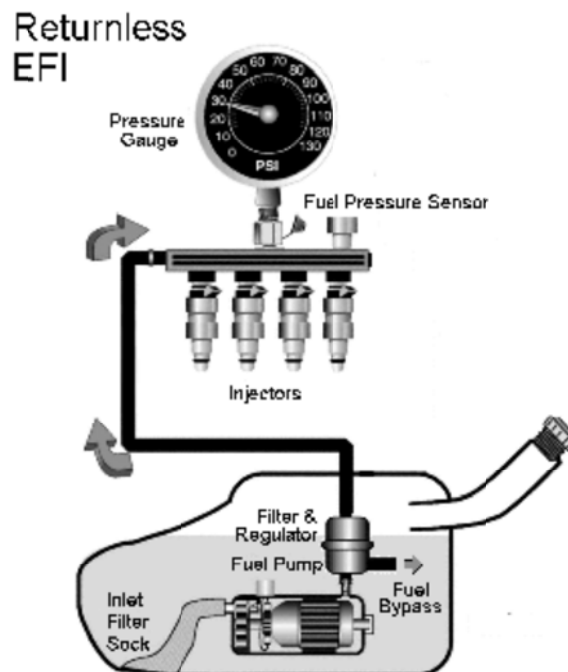

The FPM gets its commands from the Engine Control Module (ECM). There is no longer a fuel pump relay. When the ignition key is ON, 12VDC is supplied via Fuse 5 in the boot fuse box thru the FPM to the pump. **Pull Fuse 5 and try to start the car to reduce pressure in the fuel line before servicing the filter or injectors.** During engine operation, the ECM polls the requisite pressure and temperature sensors in the engine compartment to get snapshots of how things are going and commands the FPM to modulate the ground circuit of the fuel pump (between 5 and 50%) to maintain the appropriate fuel rail pressure under these conditions. When things go wrong in this simple feedback network, it can be difficult to determine precisely which component is actually at fault without specialized diagnostic equipment. It's like a series string of Christmas lights. It could be a sensor, the FPM, an injector, a filter or the pump.

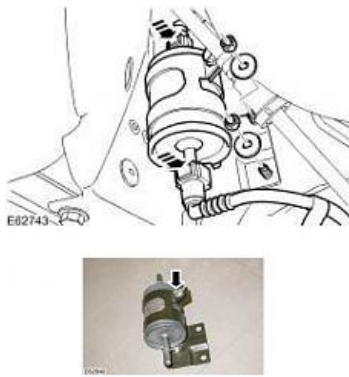

The fuel filter has changed substantially for the 2003-2005MY XK8s, although many parts suppliers still haven't gotten the word. The Jaguar OEM fuel filter is C2S20977 or W0133-1657566 (\$80) and my OEM filter had P/N 1X439155AA and "Made in Poland" stamped on it. That P/N cross references to Mahle KL83 and Mann WK512/1, (both ~\$20 from Amazon). Instead of the threaded o-ring sealed ports of the pre-2003MY XK8 filters, the new filters have 5/16" [8mm] dia straight tubes with raised circumferential ridges halfway down to capture the radial clips in the Norma-Quick disconnect fittings on the fuel lines. You'll need a special tool (Performance Tool W83152) to properly release the fittings or you risk damaging their internal latching and/or sealing features. A kit of different sizes (Performance Tool W89338) for a wide variety of other automotive plumbing applications is also available. If any supplementary plastic barbed fittings are provided with the new fuel filter, they may be cut off and/or discarded.

The inline fuel filter, located in the left rear wheelwell above and ahead of the axle, should be replaced every ~50K mi. It helps immensely if you get the back end of the car up on jack stands and remove the left rear wheel. Pull Fuse 5 in the boot fuse box and try to start the car to reduce fuel line pressure. The fuel system will not siphon when the filter is disconnected, as long as the pump is not powered up. Any fuel in the engine end of the line will back-drain, but the actual volume is quite small. Unscrew the single bolt holding the bracket to the underbody before releasing the hose fittings.

In the engine bay, near the fuel line fitting to the fuel rail, there is an inline Pulse Damper (a little nickel plated steel affair with a spring loaded diaphragm inside). It is not a regulator, usually causes no problems and its job is merely to smooth out pressure pulses in the system. The fuel rail itself is pretty straightforward and consists of two cross connected pipes, the right pipe having a mounting flange in front for the fuel pressure sensor and a threaded back end for the fuel temperature sensor. There is a common Schrader valve on the left side pipe next to the fuel supply line fitting.

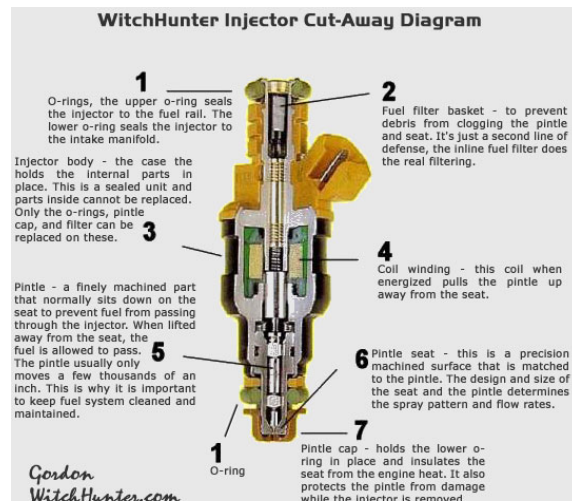

The new fuel injectors AJ82363 in the 4.2L engines have improving targeting and 12 teeny tiny orifices that need to be kept fastidiously clean. These injector bodies use the EV6 (Black w/red insert) type connector and are the high impedance (12.3 Ohm) type. Fuel injector cleaning solvents that are used in the fuel tank may help, but they won't keep these particular injectors free from muck build-up over the long term. Injector orifices and pintles accumulate varnish and the valve action can become sluggish. These injectors have very fine mesh basket inlet filters that catch the bigger debris that gets past the inline fuel filter. As one would expect, injectors nearest the dead-end(s) of the fuel rail capture the most crud. There are a number of DIY on-car solvent flushing systems (OTC 7448 and others) available for between \$120 and \$220, or you can build your own for less than half that. Off-car cleaning is much more effective than on-car flushing of the fuel rail and injectors, since you can then clean/replace the screens, verify the spray pattern and confirm flow matching. If you suspect you are having individual injector firing issues, a Noid light (Lisle 27800) or current limited LED can verify that a turn on pulse is being properly sent from the ECM with the engine running. The device will flash with each pulse. If you get good pulses, then the problem is with the injector. Another not so trusted method is to hold a long bladed screwdriver up against the injector body to your ear as a stethoscope. If you are cleaning your own injectors, keep the misting of volatile solvents contained, ground all static sources, keep sparks away, use a safe turn on voltage and keep the duty cycle lower than 80%. Keep in mind that when the injector shuts off, the back EMF may be substantially greater than the original input voltage, so I recommend using a 6 or 9V battery that can absorb it.

There are many good injector ultrasonic cleaning services out there using the ASNU or similar bench flow matching systems. Witch Hunter, Linder and AUS Injector all do good work. Flush the empty fuel rail with B-12, replace the Viton o-rings and lube them with DOT4 brake fluid or Krytox RFE prior to reassembly and leak testing.

## **Throttle Pedal and Throttle Body**

The electronic "drive-by-wire" throttle gives smooth accurate power delivery, although an overly robust pedal return spring continually fights you. There is a kick-down button near the limit of accelerator pedal travel that is akin to engaging warp drive. There is a special tool and a procedure for adjusting the cable leading from the pedal up to the "throttle by wire" sender in the XK8 Workshop Manual. The throttle body is all new and simplified for the 4.2L.

## **ZF 6HP26 6-Speed Automatic Transmission**

This gear box is very strong and used in many brands of luxury sedans and sports cars, so there are a lot of them in service. The transmission has a single planetary and dual planetary (Lepelletier) gear set providing for 6 forward gears and supporting engines with up to 444 lb-ft of torque. When placed in reverse, the ECM limits the maximum throttle body opening to 18°. ZF has their own Lifeguard6 filled-for-life fluid but all indications are that the fluid and plastic filter/pan should be changed out every 50K to 75K mi. Some claim that a better result is achieved by flushing the transmission via the cooler lines, since you can't drain all of the fluid by dropping the filter/pan. You will need to decide for yourself which method you prefer, as they both have different advantages. Maybe you should just do both, provided that you have an endless supply of money.

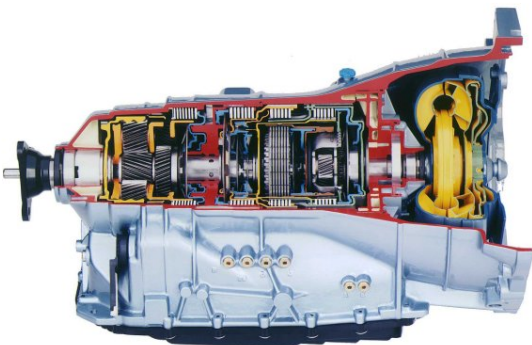

The Type A plastic filter/pan ATP 103178 is widely available. Always confirm that you can loosen the fill plug before you remove the drain plug. Early versions of this box used filter pan fasteners having T27 Torx driving recesses and apparently enough of them were getting stripped out during filter changes that ZF later switched to screws having the larger T40 driving recesses. Check yours out in advance and if you have the older screws, you should buy 21 of the T40s CTSC 0736 101 486 01 and install them with a little anti-seize compound. The connector sleeve CTSC 0501 216 272 01 should also be changed while the filter/pan is off. I don't know if the seals on this item are a high temperature elastomer, but Viton o-rings would be a good idea.

Only about 6-7 qts of the total 10.6 qt fluid capacity are accessible during a filter/pan drainage (the balance is trapped in the torque converter, lines and cooler). Refilling involves pumping fluid, running the engine, shifting thru the gears, measuring fluid temperature, pumping more fluid, all with the engine running until fluid drips out, install the fill plug, all the while working around hot exhaust pipes.

On the subject of which fluid to use, I will not enter the fray. I had my shop use Pentosin ATF1 (clear/amber colored) fluid. ZF states the need for the fluid to meet Shell M1375.4 and I have seen conflicting evidence on the web that this is the case with the ATF1. Folks have used any and all of the following: ZF Lifeguard6, the expensive Jaguar branded ZF fluid, BG 312, Amsoil ATF, Mercon and Pentosin ATF1. I am quite certain that ZF does not make their own fluid, so I strongly suspect that Pentosin is their source. I am aware that the Lifeguard6 fluid is a lower viscosity than the Lifeguard5 fluid used in the earlier 5HP24 transmissions. Different vehicle manufacturers also specify different fluids for servicing this same transmission in their cars. This box incorporates Bosch Mechatronics, so there is always going to be noticeable shift lag.

The J-Gate System allows you to lock in a lower gear for better vehicle control in town or to manually choose a more appropriate gear to get more power and/or torque depending on your driving situation without relying on the automatic transmission to do this based on generic load mapping. The Sport shift button on the console allows higher revs before hitting shift points to suit a more assertive driving style. There are reports of shifter selector switch issues and this is an apparent weak area particularly if you are used to jamming the rather delicate stick as if it were a mechanical shifter. The OEM shifter knobs on many XK8s are pretty pedestrian looking also, relative to the rest of the interior, so check out the offerings at British Autowood.

## **Driveline**

The tubular steel driveline has a Guibo (also referred to as a Jurid or Elastomeric Flex Coupling) at the transmission end and a center stabilization bearing bolted to the guard pan for refinement. Guibo replacement needs to be done very carefully to ensure that the critical balancing of the driveline is not disturbed. Always mark all bolt positions, keep them paired up with their specific nuts and don't allow anything to move until everything is back in the exact original positions. The Guibo has a directional arrow molded in, so make sure that you study everything before disassembly and that you have it facing the right way during reassembly. If it were me, I would have the Jaguar shop do this critical work. Guibos are good for ~150K mi, unless you are really hammering the drivetrain hard.

## **Differential**

The differential is reportedly a Dana44. There is no drain plug and the fill plug is in a nearly impossible to access location near the top rear of the differential. Because of this, the rear axle assembly really needs to be dropped several inches to do the lubrication service. The conventional wisdom seems to be, when the pinion seal leaks, it is time to replace it and the fluid as well. I would do this service even if the seal hasn't leaked somewhere between 100K and 120K mi. Do this at the same time as you replace the rear shock/struts to save repeat labor. Unless you have a special installation, there were no Limited Slip Differentials installed in these cars. Jack up the rear of the car (so that the half shafts can rotate freely) yearly and grease the four U-joint zerk fittings, so moisture can't get in and they should last for over 200K mi.

## Exhaust System

The exhaust manifolds are stainless steel and attached with heat shields long bolts and spacers to maintain proper tension and compensate for the different material expansion coefficients. This is a low thermal inertia system and the closely coupled catalysts are an important part of the design, but they are bare steel, so their exteriors rust badly. An EGR system was added in the 2003MY and plumbed to the intake from the engine right side exhaust manifold. There are two upstream C2C7359 wideband sensors and two downstream C2C25956 conventional lambda (O2) sensors. Both are 4-wire heated types and their lifetime is typically ~100K mi and they normally fail due to catalyst depletion. As they age they tend to report leaner mixtures, the ECM enriches the long term fuel trim in response, exhaust gases get richer, producing more carbon monoxide and hydrocarbons, leading to poorer fuel economy. Similar to my position on spark plugs, I think that replacing the upstream sensors well before end of life is good practice and probably justifies their cost vs wasted fuel.

The XK8 exhaust system is a five box stainless steel design. In our opinion, Jaguar designers went too far in reducing the music from this engine, but they were doing what they thought best for the British market. Furthermore the pipes tuck up so far above the rear axle that the bend angles are just too restrictive. There are several good aftermarket systems that replace the OEM system at quite a hefty price, because they're stainless steel, but replacing just the aft boxes with straight thru pipes can get you a nicer sound. If you feel the need for more, replace all four aft boxes or go for a full "Cat Back" system.

## Electrical System

Of all the innovative technologies introduced by Jaguar in the XK8, there is one bound to go largely unseen by owners: multiplexed electronics, not unlike the MIL-STD-1553B differential data bus protocol used in modern jet fighters. Though relatively new to automobiles, multiplex technology is thoroughly proven in the aerospace industry, where it has simplified wiring harnesses, reduced weight and improved overall system functionality.

In contrast to conventional systems, in which all features must be linked by dedicated hard-wired electrical connections, multiplexed systems control the various vehicle functions over a network of interconnected electronic modules operating by low-current switching. The control commands are encoded at the output device, such as a switch or a sensor, to be utilized at a specific destination. This coding technique (in computer terms, a communications protocol) enables many messages to travel over a differential pair of wires, rather than thru dedicated hard connections between modules. Shared usage of the communication pathway is very much like the system of roads our cars use every day: rather than providing each person in a town with their own personal road from home to workplace, home to school and home to the supermarket, all drivers share main thoroughfares, connecting to the road system through their driveways, local streets and on/off ramps. Roadways can be shared by many users simultaneously, even though they are going different places and doing different things, they follow agreed upon rules governing lane usage and right of way -- a protocol system.

The shared pathway, or data bus, brings with it an enormous boost in efficiency. With operational information made available across the entire multiplex system, control refinement advances greatly. As an example, communication between the car's various electronic control modules enables the transmission shift program to be altered when the traction control system is activated, helping the driver maintain control under slippery conditions.

When the driver switches on the rear window defogger, that message is acted on not only by the appropriate heating coil control circuits, but also noted by the engine management system. In this way, the increased electrical demand can be anticipated, and engine idle adjusted to compensate for the increased torsional load on the alternator.

The use of relays keeps switch contacts from having to carrying high DC currents that can produce pitting/arcing, but does mean that circuits become slightly more complex in the process. Having

diagrams of the fuse/relay boxes located throughout the car, combined with a listing of which relay does what, could help out tremendously in a roadside emergency and allow you to trade out a failed relay in a critical circuit with one from a less critical circuit. The brown relays LJA6703AA are the most commonly used.

The windows are frameless so, to ensure a quiet interior at speed, Jaguar developed a system that drops the windows slightly to facilitate door opening and then drives them back up into their rubber seals after door closure. Jaguar recommends that any time you work on an area that has an electrical component, the battery be disconnected before beginning work and reconnected upon completion. Some cars apparently need codes to reset the radios and such, but I have had no such issues. Any time the battery power is disconnected and then reconnected, the window limits will need to be retaught. To do this, sit inside, close both doors, close a window and hold the button until you hear a click (a few seconds after closure), then open that window all the way and hold for another few seconds until you hear a similar click. Close the window, then open the door to confirm window drop upon open and window rise upon closing of the door. Do this for the other window/door. If the battery is left disconnected for long periods, other programming may be lost and require re-training. If it keeps happening, check the battery and/or charging system. I like to make sure the car is unlocked and the keys in my pocket any time I disconnect the battery. **DO NOT disconnect the battery and then close the boot lid, as you may find it difficult to operate the seldom used manual boot lid key mechanism hidden in the right rear badge.**

The OEM battery is a wet cell unit vented to the outside thru a tube. They are usually good for at least 5 yrs. Top off the electrolyte in each cell twice a year, using distilled water. Suitable equivalent Absorbed Glass Mat (AGM or VRLA) maintenance free batteries are also available.

The internally rectified/regulated alternator is cooled by forced air (in contrast to the water-cooled unit in BMW V8s) coming from the underside of the car thru a fixed tubular "C-shaped" plastic tube. Cooling air is drawn into this tube with the aid of a removable flared plastic duct HJA4477AD (held to the steel cross bar by a single M5 bolt). This duct prevents access to the oil filter, so it is usually the first thing removed and the last thing reinstalled during an oil change, often getting misplaced by careless service personnel. It tucks up above the tubular duct at the rear (it is split on the aft end to allow the center portion to get captured inside the tube) and then clips into the radiator support at the front. The duct is not shaped like a NACA vent on aircraft, so I question its efficacy. If yours is MIA, you should probably still get a new one. For every 10°C cooler you can keep the rectifier diodes, you will theoretically double their life.

Along the sides of the engine compartment are wiring troughs that tend to collect all kinds of muck, so blast them clean with a pressure washer periodically. Along these same lines, the lower body sill rails undershoot the wheelwells, creating the ideal gravel trapping opportunity. Blast these areas clean and wax treat them periodically as well. The front splash guard tends to fill with small pebbles, leaves and such that should be cleaned out from time to time.

The molded plastic end retainer tabs on the side marker lights (and other similar polystyrene or polycarbonate lamp fixtures) stress crack over time so, while they are still new, wedge some EPDM sponge rubber between the body and the tab for support and you will extend their life. This approach also works well to reinforce the fuse box cover latches that lose their mojo in the engine bay heat.

The battery in the key remote is CR2032 and the directions for battery replacement are in the Driver's Handbook. There is also a procedure to reattach your key fob remote posted on the Jag forum. The presence of a power antenna instead of a hidden dipole that won't collect crap from the air and jam up boggles the mind. There is an Inertia Cutoff Switch tucked up behind the plastic panel just forward of the bonnet release latch that shuts off fuel, opens door locks and such during an accident sufficient to trip it.

Just a few words about British color coding. Wiring Colors are abbreviated in textual manuals.

B is Black	G is Green	K is pink
LG is Light Green	N is brown	O is Orange
P is Purple	R is Red	S is Slate
U is bIUe	W is White	Y is Yellow

A brown wire with a White tracer would be NW.

Black base colored wires indicate ground circuits, the wire connecting an electrical unit to ground, usually the car's metal chassis. A brown base colored wire is HOT or one that always has power present and is not fused.

Since the brown wires run different circuits, it is necessary to further differentiate them with the tracer color. The tracer is a different colored stripe running the length of the wire to indicate the particular job of that wire. Therefore a brown wire with a Yellow tracer is for the generator warning light while brown with a White tracer is for the ammeter.

BIUe wires are for the headlights with plain bIUe being Power to the dimmer switch, while the Power from the switch is denoted two ways. BIUe/Red (UR) is for the low beams and bIUe/White (UW) is for the high beams and the indicator lamp.

White denotes a circuit that is powered when the ignition is ON. A plain white wire runs the fuel pump, ignition relay, and various fuse box connections. White with Red tracer (WR) is the power to the starter solenoid, and White with Green tracer (WG) is power to the radio. White with Black (WB) is power to the ignition coil unless there is a ballast resistor then the wire is White with Light Green (WLG).

Slate indicates circuits that are hot when the ignition is off, such as emission control power. Purple is for always hot circuits with fuses such as courtesy lamps (PW) or key buzzers (PG or PK).

More info can be found at <http://www.icna.com/library/tech/tech0014.html>

## Suspension

The sophistication of Jaguar's suspension design has long been amongst the most highly ranked of the marque's traits. The XK8 basic suspension system design relies on long-proven components -- independent, double-wishbones up front and an independent, control-arm layout at the rear. To prevent road surface noise and vibration from reaching the cabin, suspension components are not attached directly to the XK8 body. The inboard ends of the upper and lower wishbones attach to a cast front cross beam, a structural member which spans the car from side to side. This intricate aluminum alloy casting is light and very torsionally rigid. Jaguar further enhanced its durability by heat treating and applying a Dacromet protective coating to minimize the galvanic couple where aluminum meets steel. The suspension arms bushings are specially tuned to provide the proper degree of compliance when subjected to cornering loads. Besides the suspension arms, the forward portion of the engine's weight is carried by tuned hydraulic (oil filled) motor mounts attached directly to the cross beam. I'm told that the bolts attaching the crossbeam to the frame can seize in situ after many years of galvanic action so, if you ever manage to get them out, you may need to replace them and use anti-seize compound upon reassembly.

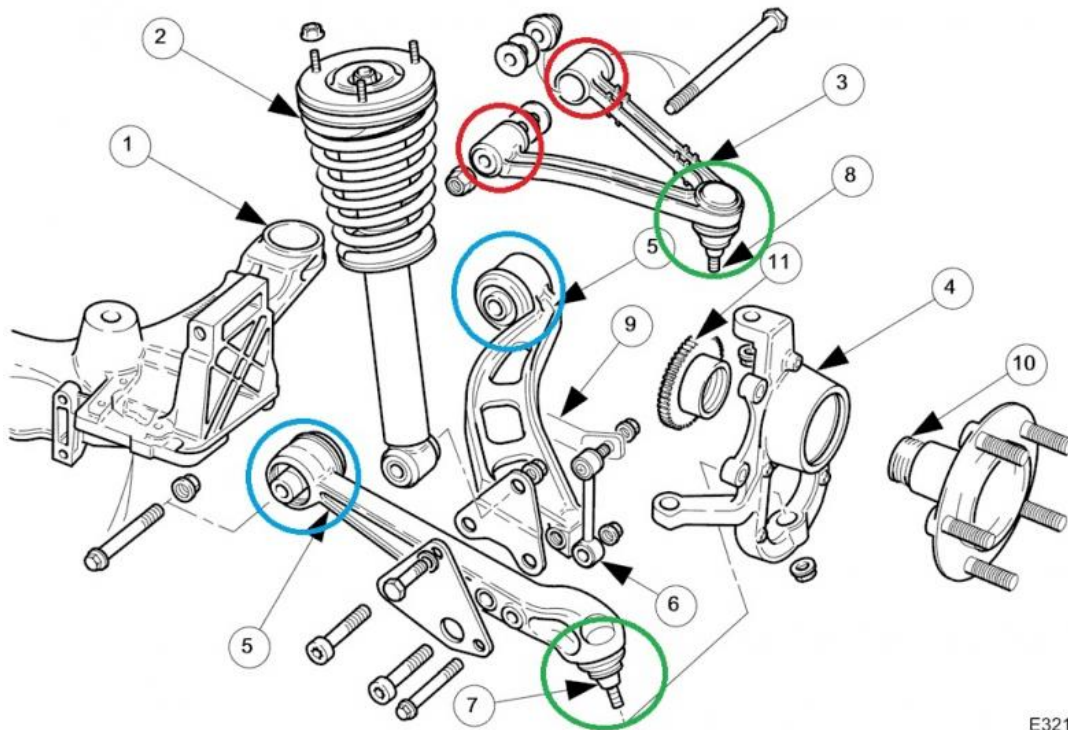

E3216f

Despite the good design, at low speeds the springs are stiff and produce a somewhat harsh ride over rough road surfaces like brick or cobblestone. At freeway speeds everything seems just about right, although I find the front-end strut rebound damping too light. A front anti-roll bar reduces body lean and the car corners as if it were on rails. The line drawing above shows the replaceable bushings. The upper ends of the coil springs, which surround the dampers, mount directly to the body, reducing the load on the lower control arm bushings to improve durability. Front wheel bearings are a robust sealed double cartridge-type, greased for life and never require repacking. They should last well over 150K mi.

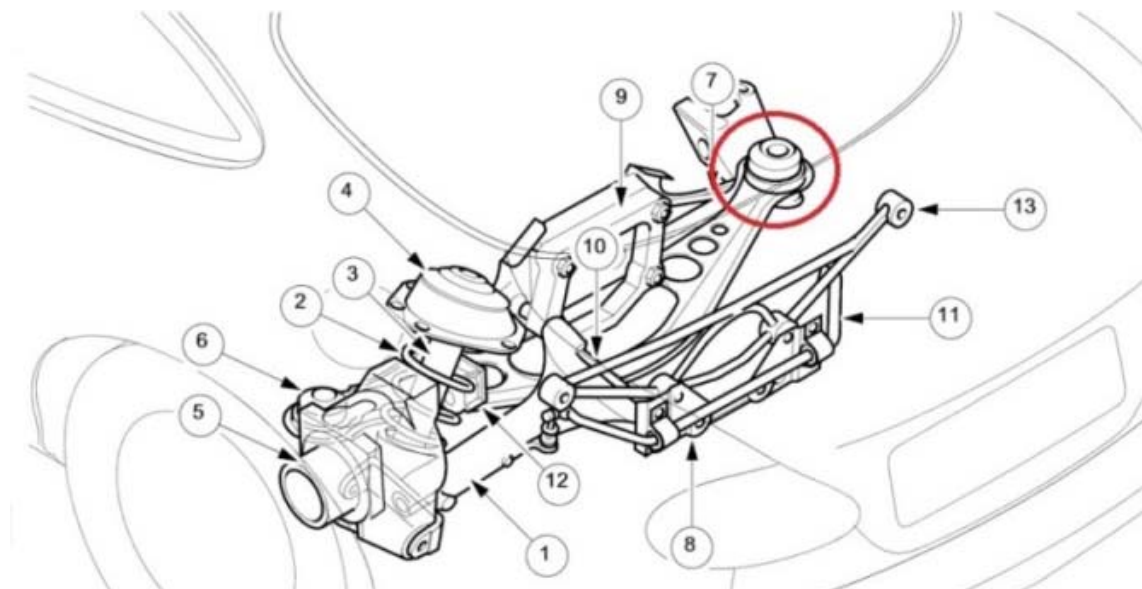

The XK8 rear suspension design shown in the line drawing above reduces the natural tendency of the car to squat under acceleration. Like the front end, the XK8 rear suspension utilizes a control-arm design, with the coil spring and damper combined into a single unit. The spring is seated directly on the cast-iron transverse lower wishbone, not the damper, which reduces friction for better ride comfort and noise isolation. The half-shafts serve as the upper suspension links.



The entire rear suspension is mounted to a stamped steel carrier cross beam, that is bolted to the body through elastomeric bushings tuned to isolate road harshness. In addition, the lower control arm pivots allow some deflection toward the rear when the wheel is subjected to the sharp impact of a pothole or bump. A rear anti-roll bar helps control body roll in cornering. Due to the limited space, a slim spring compressor like the Sir Tools ST 9050 is needed for the rear end damper work. The rear wheel bearings are not sealed for life and are probably gone by 150K mi.

I am a big fan of Powerflex brand urethane bushings when the time comes to replace any of the aging OEM elastomeric bushings used thruout the suspension. Be sure to lube the inside surface of the anti-roll bar bushings with the included grease or they are guaranteed to squeak.

The front of the car is pretty low (~5 inches at the front bumper fascia on my car), so you must learn to adjust your approach angle when negotiating driveways and gutters and never take them straight on. A 45° approach/departure with no braking dive is the best practice, or you will certainly end up scraping the plastic air dam and/or the underside of the bumper fascia. Still, I end up sanding and repainting the underside of the bumper fascia about once a year.

## **Steering**

Continuing a long-standing Jaguar tradition, the XK8 steering system is a rack and pinion design and provides a suitable level of driver feedback without compromising its luxury-class smoothness and feel. Based on ZF Servotronic components, Jaguar's advanced steering system incorporates speed-sensitive variable power assist and a variable steering ratio. Speed-sensitive power assist: the hydraulic system providing the power assist delivers full boost at low speeds for easy parking but, as vehicle speed rises, the assist lessens to give a well-weighted, confident feel to the steering at highway speeds. Due to the high assist at low speeds and the wide front tires, driving on rippled/scalloped road surfaces results in some tramlining, but you can't have it both ways. While some less sophisticated systems provide variable assist by cutting the flow of fluid to the steering rack itself, their effectiveness is hampered by the need to maintain sufficient flow for emergency evasive maneuvers at high-speeds. Using the hydraulic reaction principle to vary steering effort enables the XK8 to offer both world-class steering feel and power assist that is always available regardless of speed.

To further refine the steering feel during straight-ahead highway driving, the steering gear valve incorporates a positive center feel torsion bar. As the name implies, the torsion bar twists a slight amount in operation, effectively programming an on-center position into the action of the steering valve at small steering angles, improving stability in conditions such as crosswinds. When the steering wheel angle exceeds a predetermined amount, the torsion bar reaches the end of its travel and the control of assist levels is assumed by the Servotronic system. Variable-ratio steering: the steering rack is a design in which the rate of road wheel movement quickens as the extremes of wheel travel left and right are approached. This makes parking less tedious yet provides an appropriate level of assist -- not overly sensitive to small steering wheel movements -- for excellent stability at highway speeds.

To reduce lateral friction forces on the front tires, the steering layout of the XK8 provides near-100% Ackermann geometry. The desirability of this design arises from the fact that, in a turn, the left and right front wheels describe circles of differing diameters (the tire on the inside of the turn describes a smaller radius circle than the tire on the outside of the turn). As a result, the tires need to point at slightly different angles, though they still must return to parallel alignment when the car is traveling straight ahead. If the steering geometry design does not achieve the correct differential angles -- ideally 100% Ackermann in non-racing vehicles -- the result will be coarse turning at low speeds and higher tire wear.

Why the steering column tilt and reach motors don't always work well still mystifies me. Sometimes they function better when colder, sometimes when warmer, but they are completely functional

individual components that seem to work properly as a system only on occasion. Is there current limiting circuitry that is adjusted too near the starting current of the motors and erroneously shuts the motors down just as they start to move? When the motors stop for no apparent reason, removing/reinstalling the ignition key and/or jockeying the joystick on the side of the column repeatedly is the only way to get the column into its correct programmed position. Sometimes the tilt motor is affected, sometimes the reach motor and sometimes both. I have swapped both motors and position sensors and the system still misbehaves. The motors are good quality Bosch units, used in many vehicles that don't have these problems, so there must be another explanation. Maybe there are other contacts elsewhere in the column assy that are not robust enough for DC and they pit readily. The tilt/reach system functionality seems to get worse if unused for a long periods, so the mantra seems to be "use it or lose it".

## **Stability Control**

Standard equipment on the XK8 is automatic stability control (ASC), which reduces drive torque to the wheels by controlling the throttle position, ignition timing and fuel supply to the cylinders. An optional traction control (TRAC) adds brake intervention, using the anti-lock brake components to slow a spinning wheel.

In both systems, wheel spin is detected by the anti-lock brake sensors after comparing information supplied by all four wheel-speed sensors. Both systems may be manually canceled by pressing a switch on the center console to power out of deep snow or when using tire chains. Automatic stability control is operational at all speeds to enhance car control in slippery conditions. When wheel spin is detected, the anti-lock electronic control module calculates the engine torque level that can be utilized without causing the tires to slip, based on information from the vehicle's controller area network (CAN).

First, the throttle angle is reduced, but because the effect of this action is not instantaneous, two further measures are taken. Ignition timing is retarded (the spark plug fires later than normal) and fuel to the cylinders is cut off until the proper throttle position is reached.

## **Brakes**

The XK8 brake system is pretty much standard fare when compared with other modern luxury cars and uses the ATE Continental Teves MK25 4-channel DSC ABS unit. Unfortunately the OEM single pot single acting brake calipers are somewhat weak in their ability to act on the reasonably good sized disk to stop this car from high speed. I would like it very much if there were a good low priced option (<\$1K) vs the big chunk of change needed to upgrade to Brembos or similar. The braking ability is there if you get on the pedal harder, it's just not as responsive as my BMW X5. I use Drilled and Slotted Centric Power Stop Discs, Centric Semi-Metallic Pads (virtually no dust, much more bite than OEM pads and their stopping power only improves as they get warm) and Super Blue Racing fluid. Cool Carbon and Akebono pads are also good choices but may be noisier than the softer pads. The lower limits on rotor wear are 26mm for the front and 18.5 for the rear. Speedbleeders are available that make single person brake system bleeding much easier (two SB8125L-SS in front and two SB8125-SS in the rear). They also sell a tubing equipped plastic recovery bag (like an IV bag) that catches the expelled fluid for easy disposal, so "no muss, no fuss".



ABS Control Electronics are in the black box attached to the hydraulic block and can be removed for repair separately from the block. All the connections from the circuit board in the box and the hydraulic block are inductive. Some have experienced solder joint fractures to the circuit board that are easily rectified if you know how to solder. Unfortunately the Jaguar brake fluid lines are dressed/formed down across the face of the box, making it tough to remove without draining the system and undoing the hard lines. On most BMWs, separating the Control Electronics from the hydraulic block is a simple matter, as they do not route the hard lines in a way that obstructs black box removal. The harness connector has a sliding end bar to seat and lock the connector in place and it needs to be drawn out from the end to disconnect the harness.

## Wheels/Tires

Chrome plated wheels (both original equipment and aftermarket) can experience separation of the chrome plating over time, leading to slow escape of air from the tire bead seating area. You need to get your tire guy to inspect the plating all around the bead seating areas during tire mounting and advise you, **but this is a bad time to find out that you need a new wheel**. Another possible way of assessing their condition is to look around the perimeter of the center growler badge. If you see chrome separating (a raised area) in this region, then you can be assured that the chrome in the tire bead seating area is also compromised. Newer plated wheels that do not exhibit this concern are available, and these may be recognized by the presence of grey paint instead of chrome plating, across the inside of the wheel in the bead seating areas. This issue is covered in an SB.

Many XK8s originally came with Pirelli P-Zero tires, but I prefer Michelin Pilot Super Sports because they are asymmetrical, dual compound, super sticky and quieter than Pirellis. However they do have a rather straight cut tread that tends to track rain grooves. Whatever tires you put on, you will generally get twice as much mileage out of the front set as the rears. The rear set will usually only get you ~20K mi, depending on road surfaces and how hard you get on it. The low profile tires make wheels prone to curb rash if you are careless in picking your parking spot, so stay well clear of curbs. When you do need to buy new wheels, the aftermarket is your best option. Many of the wheels used by Jaguar came from Keystone.

These cars came with a lot of different wheel/tire size combinations over the years, but I like the sizes I have, their grip is great in all conditions except freezing, they are quiet and they turn in and out well. It seems to me that Jaguar could easily have done a better job of either zinc plating or painting the wheel hubs, as they become quite a rusty mess after only a few years of moisture ingress in and around the center caps. I hit them with a wire brush and then a light coat of VHT or Rustoleum enamel from a rattle can when doing the first brake job. Put grease on the wheel center boss to keep them from sticking to the painted steel hubs and a drop of oil on all stud threads.

Speaking of growler wheel center caps, the OEM ones that came on my car looked like they were Chinese made items bought from the toy department at Walmart. There are much nicer looking replacements available at your dealer and online in a variety of styles/colors. Why would Jaguar "value engineer" their caps/badges to cheapen their appearance in this manner? The boot release button also begins to look shoddy after a few years of normal use.

## Windscreen Washers/Wipers

The wipers are 21" and have a short length of black tubing traveling from fittings in the windscreen trough thru the wiper arms to the arm mounted nozzles. The tubing seems to be of good quality, but won't last forever, so watch it. The passenger wiper arm pivot is in the center of a very strong low pressure area creating a vacuum/venturi effect near the rear edge of the bonnet at speed (like blowing across an open bottle). The faster you drive (above 90 mph) and the longer you drive fast, the more this irresistible force wants to suck the plastic cap up and off of the wiper arm recess. It's Bernoulli's fault. I've lost two, so now I push it back down every time I see that it is riding up and I also keep a spare. The driver's side doesn't have this problem, being that it is tucked so much deeper under the bonnet edge that the low pressure doesn't act on it axially. If you lose the cap GJA8966AB, the nut and shaft will rust due to exposure and the tendency of the recess to trap moisture. The cap is made of polyethylene, so no adhesive will stick well to it.

The washer fluid system lower filler neck-to-reservoir joint is a poor fit and will leak as the rubber grommet dries out over time. Remove the unit from the left front wheelwell, disassemble the reservoir to filler neck joint. Remove the large rubber grommet and clean everything in the vicinity of the joint well with Isopropyl Alcohol. Get some silicone aquarium sealant (it has better adhesive properties than some of the other caulking silicones) and butter up both the grommet outside groove and inside surfaces with sealant. Reassemble the grommet, neck and reservoir then reinstall in the car to cure in situ.



## Soft Top

The decision to use a soft top -- rather than a hard panel -- was reportedly a deliberate XK8 styling choice. The XK8 soft top fabric and liner are attached to a folding aluminum framework engineered to provide a low "stack" height. You can operate it easily, even inside a garage with a fairly low ceiling. Operation requires pressing and holding a momentary rocker switch on the center console until a chime indicates first the start, then about 20 seconds later the completion of the soft top close or open action while traveling at up to 10 miles per hour. Latching, unlatching and rear side window operation are all automatically sequenced, but you must continue to hold the button down beyond the chime for the entire cycle to complete. When using the door key method to lower the top, the door windows are also driven to their fully down positions.

Here in the states there were many early reports of hydraulic line failures under warm to hot conditions. The dreaded "Jaguar Green Shower" happens without warning. The hose failures occur

in the windscreen frame but are virtually unheard of in the UK, so heat is definitely a factor here. Two methods of lowering the peak pressure in the system have been developed. The left photo below shows the 0.2 Ohm 100W (actually two 0.1 Ohm 50W resistors in series) pump voltage dropping resistor method and the right photo, the LSI pressure relief valve method. The valve solution is probably superior, but at a greater acquisition cost and considerably more installation work. Use only Pentosin CHF11S (green synthetic fluid) in these pumps and if you have any other fluid (earlier XK8 model years used a different brown fluid that gelled in the small diameter lines over time and temperature cycles), it must be completely purged/flushed or bad things will happen. The Soft Top hydraulics are driven by a PowerPacker brand pump that spikes to 1600 psig worst case and the hose problem has been most strongly associated with Parker hose types 303 and 363. It is unclear to me when/if these hoses were discontinued. You can read more at JagRepair.com.

The soft top hydraulic system was designed to be very compact, using small diameter hoses, long hose runs, small diameter cylinders and such, resulting in the need to run high hydraulic pressures to do the hard work of moving the soft top and actuating the latching mechanism over a great distance. This is hard on the components and the environmental conditions the system must endure may have been difficult for the UK designers to run in simulation. The pump portion of the system seems robust, but the plumbing itself and/or the termination of the fittings to the hose may both be suspect. You really should address your situation with one of these two solutions or you may have a mess on your hands.



JagWrangler.com has a spiffy modification that, once installed in the driver's door, will allow you to remotely control soft top operation using the headlamp button of your key fob remote. Certain areas of the inner liner (probably a polyester material that looks and feels like a light fleece) will get sooty along with all of the rear seat surfaces (same as the radio antenna) if you are driving around a lot with the top down. I use a combination of 70% Isopropyl Alcohol on a microfiber towel and a little steamer vacuum cleaner (VAPamore MR-50 that I have modified so as to allow both the steam generator and vacuum motor to run simultaneously) to clean the liner periodically.

## Seating and Interior

The OEM separate headrest type seats were a poor choice for a car of this caliber and, though adequate to the task of driving, they fail big time in the cornering department. Due to quirks of their design, they also have a tendency to develop creaks over time with occupant movement, requiring you to apply some lithium spray lubricant up, in and around the hinges and folds. There is also an SB for a fix to the seat riser end float. The seat position control electronics sit in a plastic enclosure under the front of the seat bottom and after years of seat loading impact, the cases or lids can crack and rattle. There is an SB that offers a replacement lid C2N3565. The range of seat motion is somewhat limited for long legged drivers and the seat can only go back so far as the rear seat bolster will allow. Top up, there is just enough head room and I'm 6' 2". I have the seat base height all the way down both front and back.

The headrest drive cables can be troublesome, but there is an SB fix and fellow Pastafarian Reverend Sam has a YouTube video describing correcting the sheath length, so that the internal cable ends fully engage in the drive spindles. Use a good quality ½" starting diameter semi-rigid wall heat shrink tubing having a meltable adhesive inner liner (meeting AMS-23053/4-105-0) when doing this SB (don't use duct tape) and this fix will last forever. The headrest automatically lowers when the seat back is tilted forward. This feature is controlled by a microswitch on each seat frame. The seat side release lever allows the seat back to tilt forward, actuating the microswitch and running the motor to retract the headrest. When the seat backrest is returned to the normal driving position, the microswitch causes the headrest to run to its preprogrammed position. Be aware that these microswitches are mounted externally on the seat frames facing the driveshaft tunnel and can easily get dislodged by careless vacuuming of the interior.

The driver's seat lumbar bladder was in the wrong vertical position for my back, but it can easily be adjusted by disassembling the rear of the seat back and changing the tie wrapped height of the bladder relative to its rubber mounting web.

Starting 2003MY there is a flux gate compass equipped rearview mirror. The cup holder is completely laughable, but take heart as a rebuild kit is available if you break yours. Was there really no room for a proper one? The center console armrest "goody tray" cover foam gets compressed and the leather starts to ripple and begins to look bad over the years. Better foam is probably a good retrofit. Sam's got this, as well as many other XK8 DIY activities, covered in YouTube videos too.

Another weak area is the door weather stripping, but only in two areas. The molded rubber can split where the window glass edges exit at the front just above the mirror and at the rear just above the door latch. The cost of replacement is significant and installation laborious. There is a solution that has worked for me. For the front split, just trim off the split sharp corner and smooth it into a more rounded corner with a Dremel tool sanding drum. For the aft end, buy some Permatex Black Rubber Sealant #80338. Put some in a non-waxed paper mixing cup, add a little Acetone to thin it out to brushing consistency and make sure it's mixed real well. Clean the rubber area adjacent to the repair area really well using Acetone. Scrub the area real well to get the release agents off. Using an acid brush, apply the mixed liquid in multiple thin coats. If you need to, use masking tape to hold any split area together and drip some of the rubber mix down the inside of the rubber strip. Let setup overnight and reapply as necessary until the area looks like new.

I like dash mats in all of my vehicles and Cover King makes a good velour one. Just make sure that you get the Velcro anchors stuck well to the glare shield surface, as having a dash mat fly up in your face on a convertible at speed could be really dangerous. I found that the acrylic adhesive equipped Velcro didn't work well (the acrylic adhesive softens in the heat), so I ended up using Acetone as a cleaner and Contact Cement to bond the anchors down. Gorilla glue may also work well, but use it sparingly since it expands during curing.

There is a microswitch inside the door on the latch mechanism that can degrade over time and there is a fix for it, so when your door doesn't sense that it has been closed and bump the glass up, and you have in fact reset the window glass limits, it may be time for a new switch.

Regarding "popping" door hinges, the hinge foot attached to the body shell shears from one tangent point of the bolt clearance hole to the opposite tangent point as the door is opened and closed. It is basically just snapping back and forth because the bolt has loosened, and Jaguar hasn't bothered to shake proof the fastener. It normally occurs on the driver's side first, because that's the door that gets opened and closed the most. Remove the bolt and reinstall it using some Loctite 242 and retorque securely (about 5 ft-lb [60 in-lb]), and your problem is solved.

## Climate Control

On the knee bolster there is a little plastic grille behind which lies a reference thermistor and fan for the climate control system to key off of. This item gets dirty so the climate control system can't accurately determine the temperature of the interior and appropriately throttle the system's resources. A little bit of dash disassembly is required using plastic pry tools -- go slowly so you don't break anything. Clean the thermistor with a little Isopropyl Alcohol and reassemble. It might be a good thing to power up the fan with 12VDC to ensure it still works. There are also concerns with the heater system coolant circulation pump getting gunked up and the commutator brushes wearing out over time. Access for this disassembly is difficult.

## Restraints

Extensive safety considerations are engineered into the XK8. There is a sophisticated onboard system constantly assessing the occupancy/position of those in the cabin and providing for optimum deployment of the airbags under a wide variety of conditions. Dual seat bolster airbags are provided for the driver and front passenger, along with pyrotechnic seat belt pre-tensioners to take up seat-belt slack during impact.

## Pollen Filters

There are no OEM interior pollen filters or filter boxes under the bonnet of any XK8s sold in the states and seriously, do they even work on convertibles?

## Heat Soak

Due to the fact that the engine bay is largely full of, well ... engine, there is little room for anything else that doesn't help get you on down the road. Heat produced by the engine and conducted through the attached alloy structures needs to be forcibly ejected by moving the car spritely down the road, so "stop and go" traffic should always be avoided. This is a touring car made for the open road. As the hot engine is shut down, all that waste heat bakes into the surrounding structures including the fuel rails, wiring harnesses, plastic and rubber parts. Heat drives out the plasticizers and emollients in plastic and rubber parts respectively. There are many difficult to reach/replace hoses in and around the firewall that are subject to drying out and cracking with dire results. The radiator fans are electronically controlled and don't run at all when the engine is first started cold, run slowly (electrically connected in series) at coolant temperatures of around 190°F and then run at full speed (electrically connected in parallel) at coolant temperatures around 204°F. In our opinion, the designers really should have programmed the controller to keep power on the fans at lower temperatures for several minutes following hot shutdown to combat this heat trapping tendency. The point being, heat will have a lasting cumulative effect on the contents of the engine bay, so inspect, maintain and act accordingly.

## Protection

Keep all hoses, and for that matter all rubber items (except the serpentine belt), well coated with a good silicone oil spray for longest life. Don't waste your time and money on silicone sprays sold in most auto parts or hardware stores, the industrial rated stuff is much better. I recommend using the food grade low viscosity spray CRC 03040 (Fastenal carries it) for large area coverage and Easy Rider RT630A (paint ball aficionados use it) for coating small bushings, because it is thicker and clings better. Dupont makes a Krytox Spray with PTFE for bicyclists that has numerous applications for cars.

If your XK8 is a daily freeway driver, you do need to protect the front end against FOD. Sadly, the C2S4496 Front Bonnet Protector (black vinyl bra) was never reconfigured for the front end changes made in the 2003MY, so it ends up being a marginal fit around the driving lamps and the lower intake areas. The intake mouth of the newer grille is a different shape and deeper, so the plastic clips don't reach. You will need to make your own bungee attachments to adapt it to the 2003 – 2005MY range, preferably scallop the lower portion to clear the bottom intake and re-hem it so as not to block air flow to the lower radiating fins. You will also need to make some loops (I formed some of .032" dia

stainless steel aircraft safety wire) to hold the bra corners up and back using the fir tree clips of the wheelwell liners as anchor points. A clear protective film bra is also available from custom installers.

Convertibles get very dirty inside when you drive around a lot with the top down. I use Lexol wipes to clean then Surf City Garage Voodoo Blend Leather Rejuvenator to treat the leather. The outboard piping on the driver's seat back and surrounding area will get rubbed raw by your derriere long before any other leather surface except the console armrest starts to show wear, so maybe protecting this area with a pad or something similar is a good idea. New seat skins are available from GAHH, but are quite expensive.

Other protectants may be needed in different climates. Noxudol 750 anti-corrosion treatment cavity wax should be applied on and/or into all places you can get to with the included snaky hose that might be subject to moisture ingress and road salt effects. Remove the plastic front wheelwell liners for access and apply wax in these areas too. If you can get the car up on a lift, look for lower areas that are prone to moisture or rusting and apply it (just don't get it on braking surfaces or items that must move freely without binding). The steering linkage knuckle U-joint is an area that has a tendency to rust badly, so wax it regularly.

For soft top external fabric cleaning and protection, I use the Raggtopp system to clean and treat the fabric twice a year.

For treating the fuel injection system I prefer Berryman's B-12 Chemtool, but Valvoline Syn-Power VPS and BG 44K are also good choices.

There isn't much plastic on the XK8, but the best plastic treatment I've found is Meguiar's Ultimate Protectant (more water resistant than Armorall).

## Lighting

My XK8 has the OEM Halogen headlamps including washers and I don't plan on converting to HID, as they are quite satisfactory as is. The headlamp lenses are non-safety glass (and quite sharp when shattered) and, as a result, prone to FOD damage. I recommend applying the X-Pel 3M protective film appliques (~\$50) to the glass ASAP or you may be buying a \$260 lens (left W0133-1657394, right W0133-1657395) sooner than you would like. The film kit I bought had six precut pieces to cover all the individual headlamp glass surfaces including the driving lamps and washer nozzle half moons.

Halogen lamps are available in various enhanced performance versions and should always be used in pairs so that the color and intensity of the beams on one side of the car are substantially similar to the other side. All other lamps are available in Long Life or LED equivalents. It's a personal thing, but frankly, I find LEDs used in brake light applications really irritating/startling, because they come on so abruptly, vs incandescents. The XK8 Driver's Handbook page 6-17 is incorrect regarding the proper lamps fitted as Fog Lamp, Dipped (Hi) Beams and Main (Lo) Beams. The below listing is correct. It was nice of Jaguar to give us an unused spare lower center position lamp that can be traded out in emergencies for a failed rear/stop lamp in each fixture. Replacement lamps are as listed below:

<u>Position</u>	<u>Sylvania P/N</u>	<u>Description</u>
• Front Lo Beams (2)	H1	STR 55W Halogen
• Front Hi Beams (2)	9005	RA 65W Halogen
• Front Parking (2)	2825 LL	5W
• Front Turn Signal (2 YELLOW)	7507A LL	Y21W
• Front Fog/Driving (2)	H1	STR 55W Halogen
• Front Side Marker (2)	2825 LL	5W
• Door Puddle (2)	2825 LL	5W
• Glove Box (1)	3893	T4W or LED
• Interior Panel (4)	194	LED



• Interior Footwell (2)	2825 LL	5W
• Interior Dome (1)	6411 LL	10W
• Interior Map (2)	2825 LL	5W
• Rear Side Marker (2)	2825 LL	5W
• Rear Tail/Stop (2)	7528	21W/5W
• Rear Center (2 Spare)	7528	21W/5W
• Rear Turn Signal (2 YELLOW)	7507A LL	Y21W
• Rear HMSL (1)	2825 LL	5W
• Rear Back Up (2)	7506	21W
• Rear Fog (2)	7506	21W
• Rear License Plate (2)	2825 LL	5W
• Rear Boot (2)	6418 LL	5W or LED

## OBD2

The OBD2 system is conventional and an appropriate scan tool (I have an Innova 3130) will return Diagnostic Trouble Code (DTC) P1111 when all systems are “in the green”. Get a good list of Generic and Jaguar specific DTCs so that, when your car throws a DTC you don’t recognize, you can at least have a rough idea of what is going on. Some tools are more sophisticated than others and many auto manufacturers are very keen to keep their OBD2 details proprietary. The Autologic, AutoEnginuity and ScanXL tools are high-end tools for professional shops, the Snap-On Ethos is a good mid-range tool and the Innova Equus series are decent low-end tools for the DIY’er. Scan your car’s systems Key-ON Engine-OFF (KOEO) and read the live data Key-ON Engine-Running (KOER) while driving at varying speeds when things are running good, so that you will be able to recognize normal range readings. The live data can often be captured in memory and subsequently uploaded to your PC to produce graphs and reports. Do not begin replacing things on a single throw of a given DTC, but do use the tool and OBD2 system to help you baseline, monitor and troubleshoot your car’s systems and look for trends over time. Try to develop a good diagnostic sense that allows you to proceed logically to narrow down and pinpoint the malfunctioning item in the system. There are a number of good YouTube videos that can help you to hone good troubleshooting skills.

As with all systems, their ability to function as designed depends on each component doing its job correctly and consistently. The OBD2 diagnostic capability helps to pinpoint which of the many components is the slacker in any given subsystem and allows you to channel your diagnostic and corrective efforts methodically towards those items most logically responsible for the fault. Like Sherlock Holmes, take your time in sorting thru the evidence and try to eliminate the extraneous to arrive at the truth, and “Don’t fix it, if it ain’t broke”.

Following are some of the normal range OBD2 Parameter Identifications (PIDs) accessible by my tool:

Fuel System 1 (KOEO Open Loop, KOER Closed Loop)  
 Fuel System 2 (KOEO Open Loop, KOER Closed Loop)  
 Calc Load (KOEO 0% KOER 0 to 100%)  
 Eng Cool Temp Sensor (-30 to 260°F)

Short Term Fuel Trim B1 (-10 to 10%)  
 Long Term Fuel Trim B1 (-10 to 10%)  
 Short Term Fuel Trim B2 (-10 to 10%)  
 Long Term Fuel Trim B2 (-10 to 10%)

Fuel Press Sensor (50 to 60 psi)  
 Man Air Press Sensor (0 to 30 inHg)  
 Engine Speed (0 to 6400 rpm)  
 Vehicle Speed (0 to 155 mph)

Spark Adv Cyl #1 (0 to 45°)  
Intake Air Temp Sensor (0 to 130°F)  
Man Air Flow Sensor (0 to 30 lb/min)  
Throttle Pos Sensor (0 to 100%)

O2 Sensor B1 S2 (.2 to .8 V) .45 V is ideal  
O2 Sensor B2 S2 (.2 to .8 V) .45 V is ideal

Malfunction Indicator Lamp (MIL) ON/OFF