

# JAGUAR Lamp Control Module LJA 2245 AD /05 8200 00

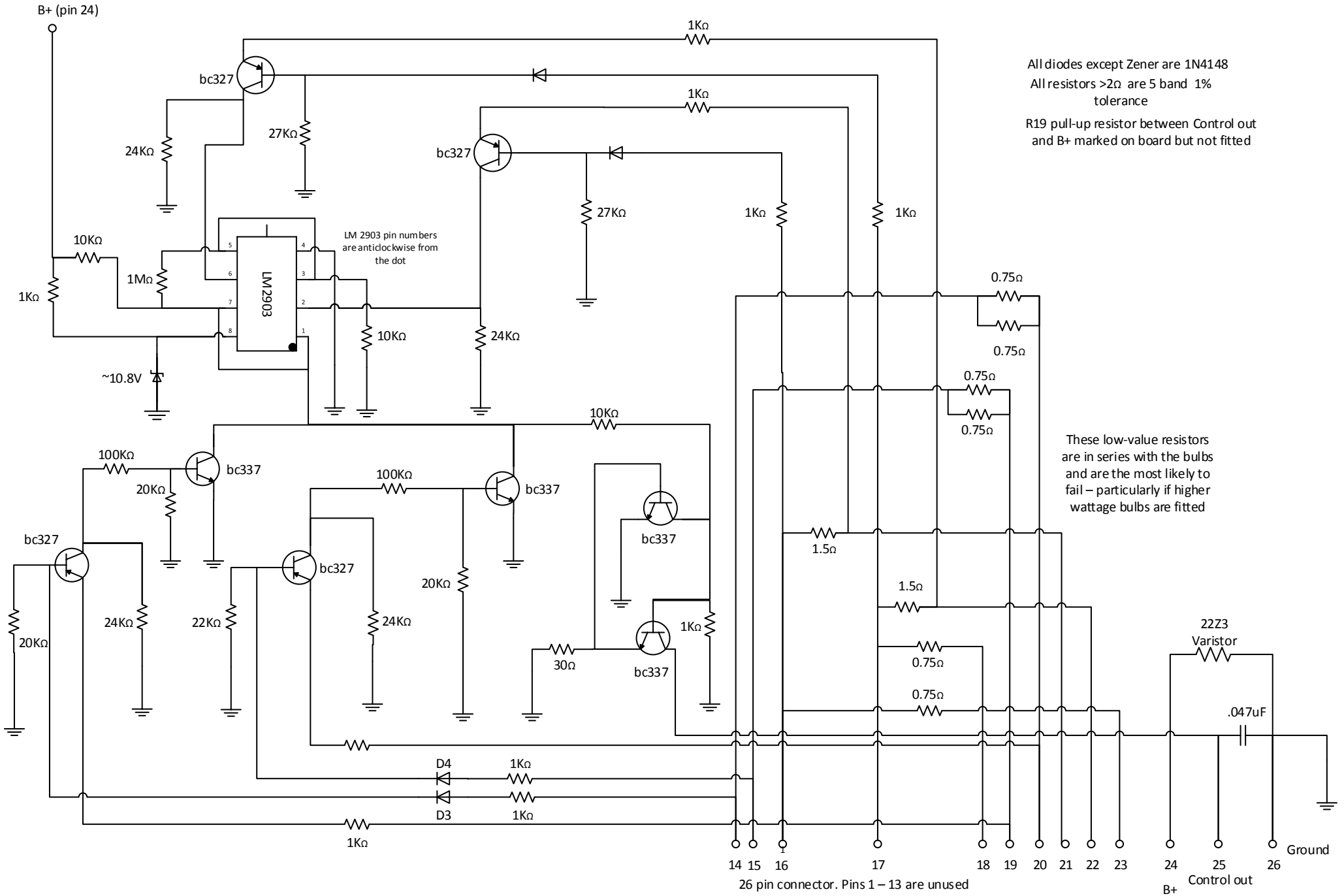

All diodes except Zener are 1N4148  
 All resistors >2Ω are 5 band 1% tolerance

R19 pull-up resistor between Control out and B+ marked on board but not fitted

These low-value resistors are in series with the bulbs and are the most likely to fail – particularly if higher wattage bulbs are fitted

26 pin connector. Pins 1 – 13 are unused

Ground  
 B+ Control out

Switched 12V lines from trunk fusebox

