



V8 XJ Series/XK

DATE 08/04
Amended 11/04

303-S514

SERVICE

TECHNICAL BULLETIN

Operation Of Throttle While In Closed Position – Service Action S514

MODEL
1997-98 MY XK8 Range
1998 MY V8 XJ NA
VIN 1998-99 MY V8 XJ S/C
Refer to text

Remove and destroy Bulletin 303-S514, dated 08/04.
Replace with this Bulletin.
Revisions are marked with a bar and in **bold text**.
References to the tie strap for plastic adjustment nuts
have been added on page 10.

Issue:

A concern has been identified with the operation of the throttle on a number of 1997-98 MY XK8, 1998 MY XJ8 and 1998-99 MY XJR and VDP SC vehicles. Under exceptional circumstances this concern could cause the engine to cut out, although the engine will continue to be driven by the road wheels through the transmission and drive the ancillaries, so there will be no loss of power steering, brakes, air conditioning, etc. The engine should restart without difficulty once the vehicle has come to a complete standstill.

Action:

Perform this Service Action on **all** vehicles within the VIN ranges listed below, **both in and out of new vehicle warranty**.

To aid in the identification of repairs required by vehicle, the table below provides a breakdown of the repair required by model year, model, and VIN range. Workshop Procedures are included in this bulletin.

Model Year	Model	VIN Range	Repair Required
1997 to 1998	XK	001036 to 020734	Reprogram ECM - page 2
1998	V8 XJ (both NA and SC)	812256 to 819771	Reprogram ECM - page 2
1998	XK	020735 to 031302	Replace throttle body - page 4
1998	V8 XJ NA only	819772 to 853935	Replace throttle body - page 4
1998 to 1999	V8 XJ SC only	819772 to 878717	Replace throttle body - page 4

⚠ Caution: For those vehicles that require ECM reprogramming, use only Worldwide Diagnostic System (WDS) release JTP759/33, or later.

NOTE: THE INFORMATION IN TECHNICAL BULLETINS IS INTENDED FOR USE BY TRAINED, PROFESSIONAL TECHNICIANS WITH THE KNOWLEDGE, TOOLS, AND EQUIPMENT TO DO THE JOB PROPERLY AND SAFELY. IT INFORMS THESE TECHNICIANS OF CONDITIONS THAT MAY OCCUR ON SOME VEHICLES, OR PROVIDES INFORMATION THAT COULD ASSIST IN PROPER VEHICLE SERVICE. THE PROCEDURES SHOULD NOT BE PERFORMED BY "DO-IT-YOURSELFERS." DO NOT ASSUME THAT A CONDITION DESCRIBED AFFECTS YOUR CAR. CONTACT A JAGUAR RETAILER TO DETERMINE WHETHER THE BULLETIN APPLIES TO YOUR VEHICLE.



RE-PROGRAM ENGINE CONTROL MODULE (ECM)

1997-98 XK 001036 to 020734

1998 V8 XJ (both NA and SC) 812256 to 819771

Note: Before continuing, ensure the following:

- The PTU is docked on the base station.
- The WDS base station is connected to the line power supply.
- The vehicle battery is in a good state of charge (12.5 volts).
- All Diagnostic Trouble Codes (DTCs) are cleared.

The engine coolant and intake air temperatures MUST be below 50° C (122° F) for the following operation.

⚠ Caution: Do not attempt to 'trick' the system by cooling the ECT sensor or substituting a different ECT sensor. The EPROM within the ECM is temperature sensitive and must be cool for programming to take place correctly. Failure to follow the guidelines may result in the ECM becoming inoperative, which will result in non-payment of the warranty claim.

Component Locations

During the reflash procedure, the WDS will prompt the technician to temporarily remove relays and fuses. **Since some fuses can be confused with similar ones in other locations**, refer to the chart below before beginning the reflash procedure.

	XK	V8 XJ Series
EMFR01 relay	in fusebox located in front of ECM in control module enclosure (cool box)	in Engine Management fusebox located on left front fender
EMF012 fuse	Fuse 12 (red 10 amp) located in fusebox located in front of ECM in control module enclosure (cool box)	-
EMF014 fuse	-	Fuse 14 (red 10 amp) located in Engine Management fusebox located on left front fender
BTFR04 relay	in trunk fuse box	in trunk fuse box

Note: This information can be checked at any time by using the Connector Information Viewer (CIV) in WDS.

XK8 Vehicles equipped with KTM only – VIN range 018108 to 020733

1. On the driver side of the vehicle, release and remove the instrument panel end fuse aperture cover (for access).
2. Release and remove fuse number 6 from the 18-way fuse box.

Note: Fuse 6 is located on the right-hand row of nine fuses, sixth fuse down from the top. It is tan in color and the rating is 5 amps.

3. Continue to procedure below.

XK8 vehicles not equipped with KTM (VIN 001001- 018107) and all V8 XJ Series (VIN 812256-819771)

1. Position World Wide Diagnostic System (WDS) alongside vehicle, switch Portable Test Unit (PTU) 'ON' and allow software to load.

Note: Ensure WDS is loaded with software release **JTP 759/33 or later**.

2. Connect PTU to vehicle using diagnostic cable.
3. Enter vehicle VIN and navigate to configuration main menu.
4. Select and run 're-configure existing ECM' application.
5. After the re-configuration of ECM is complete, switch 'OFF' PTU, disconnect from the vehicle and return WDS to original location.
6. Re-install fuse.
7. Re-connect connector.

REPLACE THROTTLE BODY

1998	XK	020735 to 031302
1998	V8 XJ NA only	819772 to 853935
1998 to 1999	V8 XJ SC only	819772 to 878717

1. Disconnect the battery ground cable; refer to Global Technical Reference (GTR), Workshop Manual, section 414-01.
2. Remove the air cleaner cover/intake assembly.
3. Disconnect the connectors and vacuum pipe.

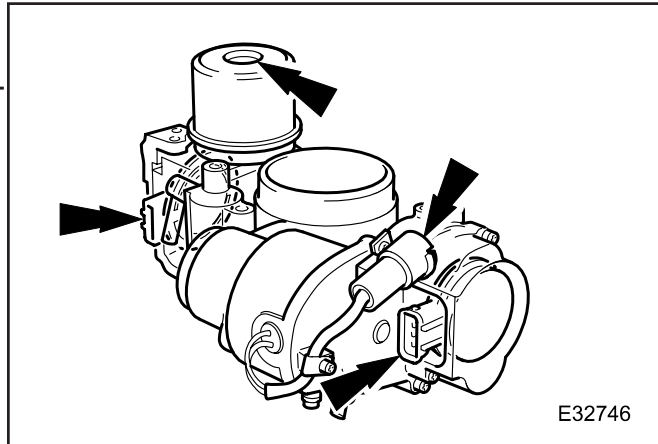

ILLUSTRATION 1

4. Rotate the throttle quadrant to allow disconnection of the inner cable.

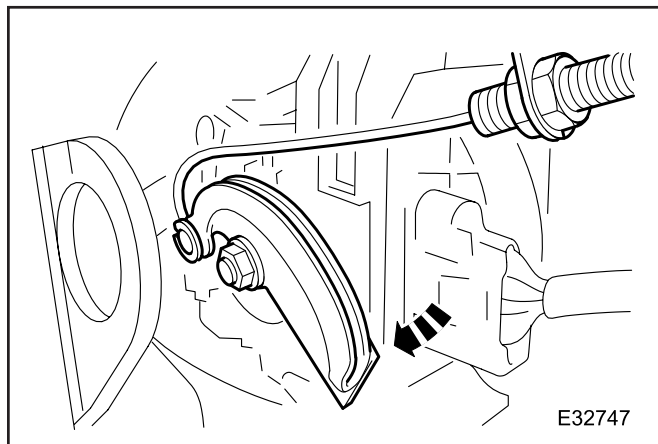

ILLUSTRATION 2

5. If installed, release the cable tie fitted around the throttle cable adjuster nut and the abutment bracket, and displace the throttle cable adjuster nut from the abutment bracket.
6. If installed, release the throttle cable-locking nut and displace the outer cable from the abutment bracket

Note: Do not disturb the adjusting nut.

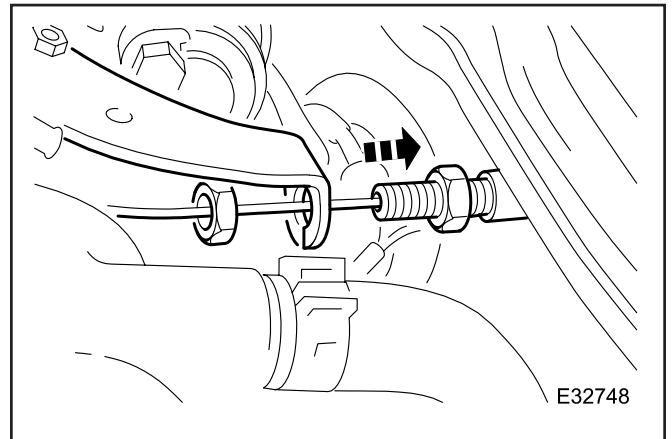

ILLUSTRATION 3

6. Remove the coolant hoses and install suitable blanking plugs.

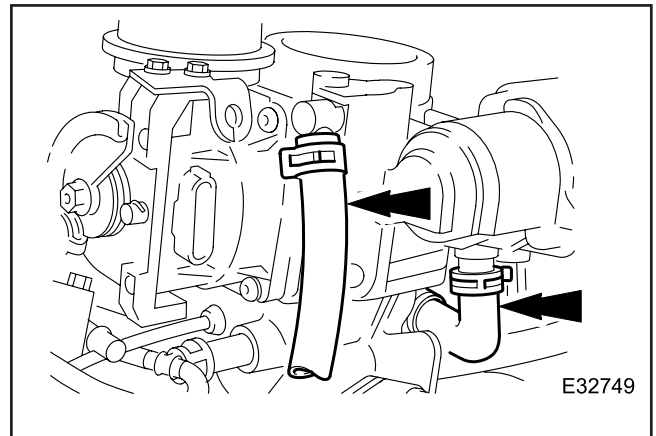

ILLUSTRATION 4

7. Release the connector from the bracket under the left hand side of the assembly.

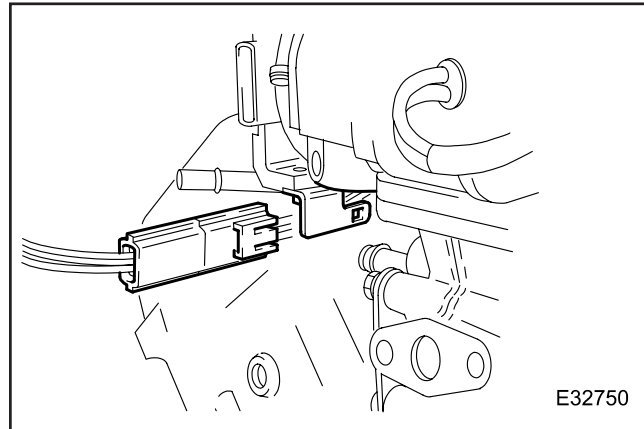

ILLUSTRATION 5

8. Remove the throttle body to induction elbow securing bolts.

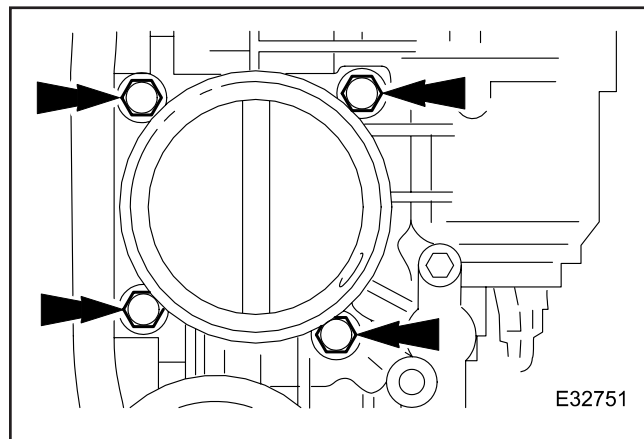

ILLUSTRATION 6

8. Remove the throttle body from the induction elbow, discard the gasket, and blank off the inlet tract to prevent ingress of foreign matter.

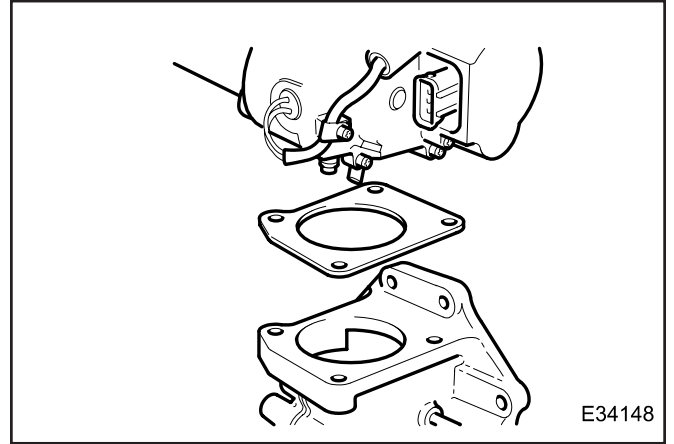

ILLUSTRATION 7

9. Remove the throttle cable and intake duct bracket.

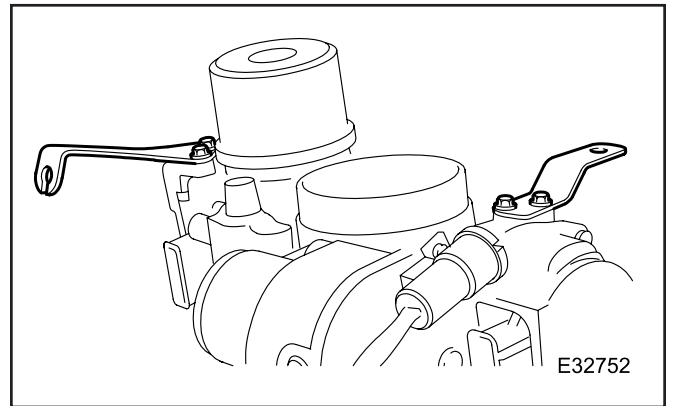

ILLUSTRATION 8

Note: Cut the wires to the motor of the displaced throttle body to make the throttle body inoperative and then discard.

INSTALL THROTTLE BODY

10. Install throttle cable and intake duct brackets.

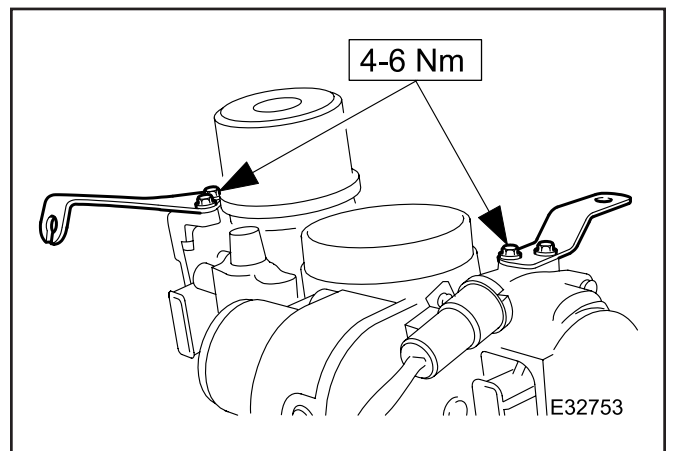

ILLUSTRATION 9

11. Install new throttle body gasket. Install new throttle body.

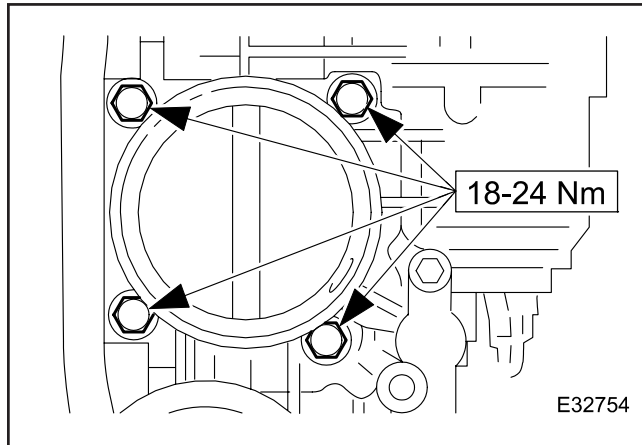

ILLUSTRATION 10

Note: The new throttle body has a Molykote coating and cannot be cleaned. The new throttle bodies can be identified by a sticker (Illustration 11).

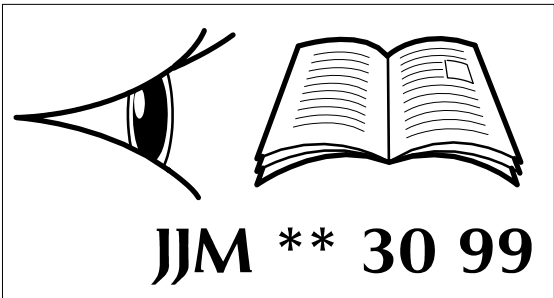

ILLUSTRATION 11

12. Install connector.

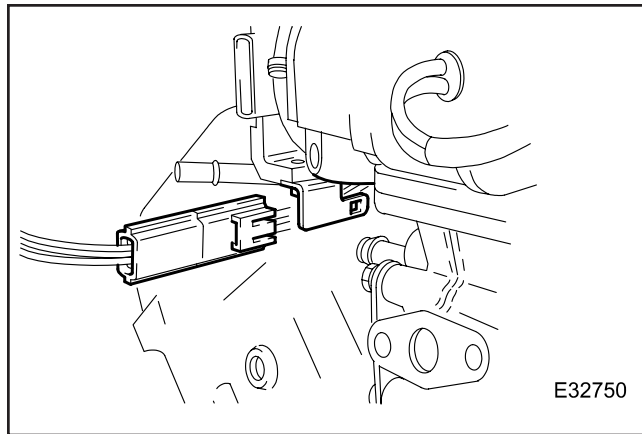

ILLUSTRATION 12

13. Install coolant hoses.

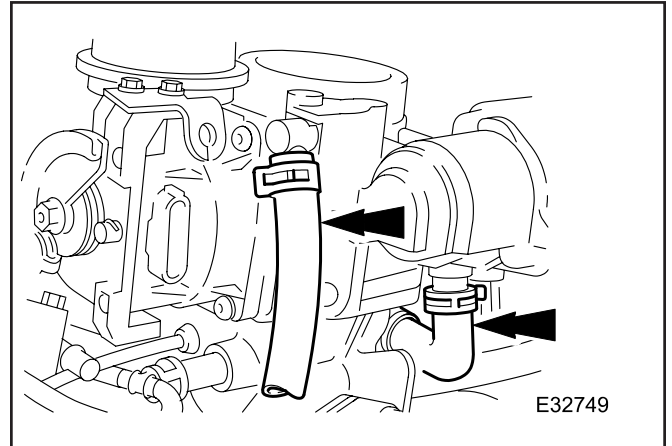

ILLUSTRATION 13

14. Reposition outer cable to abutment bracket and install, but do not fully tighten, the adjusting nut.

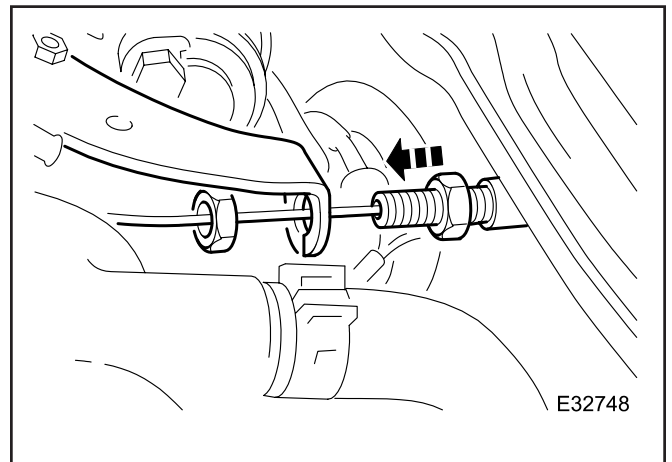

ILLUSTRATION 14

15.

⚠ Caution: Under no circumstances should the quadrant be held clear of the throttle stop by cable tension. Ensure there is no tension or slack in the cable.

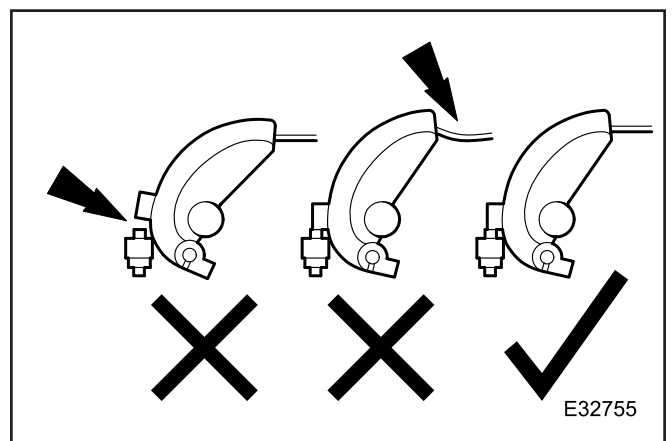

ILLUSTRATION 15

Install the throttle cable. Tighten the locknut without altering the setting or introducing any twist into the outer cable.

16. **⚠ WARNING: FOR VEHICLES WITH THE PLASTIC ADJUSTMENT NUT, AFTER CORRECT CABLE ADJUSTMENT, YOU MUST INSTALL A RATCHET TIE STRAP TO FULLY RETAIN THE ADJUSTER NUT IN ITS LOCATION WITHIN THE ABUTMENT BRACKET, (ILLUSTRATION 16) REFER TO RECALL ACTION R466.**

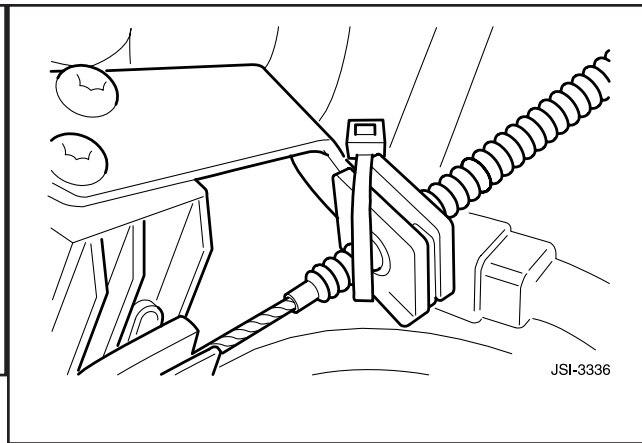

ILLUSTRATION 16

17. Connect the connectors and the vacuum pipe (Illustration 17).

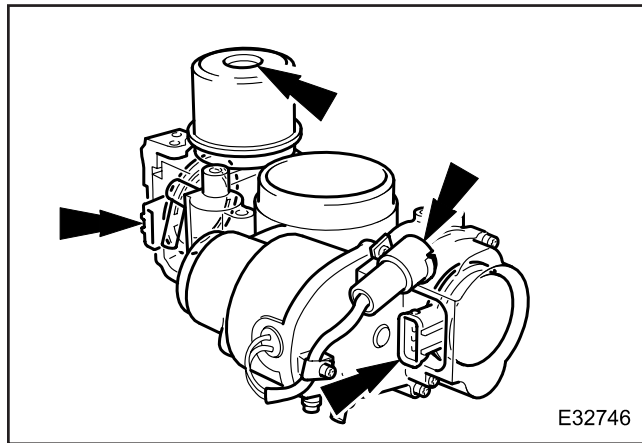

ILLUSTRATION 17

18. Install air cleaner cover/intake assembly.
 19. Check the coolant level and top up if required.
 20. Reconnect the battery ground cable, refer to Global Technical Reference, Workshop Manual, section: 414-01.

Note: Only throttle bodies with an EK suffix can be used in this Service Action. In addition, throttle bodies with an EK suffix must **not** be used to repair any vehicle not covered by this service action.

Parts Information:

<u>DESCRIPTION</u>	<u>PART NUMBER</u>	<u>QTY</u>
Throttle body	C2A 1470 EK	1
Gasket	NCA 3021BA	1
Ratchet tie strap	ADU 9028	1

PARTS SUPPLY INFORMATION

An initial supply of throttle bodies/gaskets will be allocated to each dealer based on size and volume to ensure an even distribution and full coverage during the initial launch phase. After the initial allocation, parts should be ordered according to actual demand requirements from Jaguar Parts Operations following normal procedures. All other parts required should be ordered through Jaguar Parts Operations following the normal process.

If you require parts or technical assistance, please contact 1-888-JagDlrs.

Global Technical Reference (GTR) Workshop Manual Information:Dealer Access: <https://hub.franchise.jaguar.com>Internet Access: <http://www.jaguartechno.com>**Warranty Information:**

Warranty claims should be submitted quoting the information found in the table below. This will result in payment of the stated time and, where applicable parts/miscellaneous expense codes as listed.

Use S514 as the program code with the relevant option code and **also enter** the SRO (s) and parts details on the claim applicable to the repair completed.

Service Action S514

Model	Year	VIN Range	
XK Range	1997 MY	VC 001001 -	VC 018107
XK Range	1998 MY	WC 018108 -	WC 031302
V8 XJ Series	1998 MY	WC 812256 -	WC 853935
XJR	1999 MY	84*XC 853936 -	84*XC 878717

Model Year	Model	VIN Range	Repair Required
1997 to 1998	XK Series	001036 to 020734	Reprogram ECM
1998	V8 XJ Series (both N/A and SC)	812256 to 819771	Reprogram ECM

Program Code	Option	Description	SRO	Time	Part Number	Part Description	Qty
S514	B	Reprogram ECM	86.99.13	0.4 hrs.	-	-	-
S514	C	Reprogram ECM	86.99.13	0.4 hrs.	-	-	-
		Drive in/drive out	10.10.10	0.1 hrs.			

Note: Only throttle bodies with an EK suffix can be used in this Service Action. Throttle bodies with an EK suffix must not be used to repair any vehicle not specifically covered by this service action.

Model Year	Model	VIN Range	Repair Required
1998	XK Series	020735 to 031302	Replace throttle body
1998	V8 XJ Series N/A only	819772 to 853935	Replace throttle body
1998 to 1999	V8 XJ Series SC only	819772 to 878717	Replace throttle body

Program Code	Option	Description	SRO	Time	Part Number	Part Description	Qty
S514	D	Replace throttle body and gasket	19.91.65	0.5 hrs.	C2A 1470EK NCA 3021BA ADU 9028	Throttle body	1
						Gasket	1
S514	E	Replace throttle body and gasket	19.91.65	0.5 hrs.	C2A 1470EK NCA 3021BA ADU 9028	Throttle body	1
		Drive in/drive out				10.10.10	0.1 hrs.
						Tie strap	1

Note: Always perform a DDW claim search first to determine whether this service action has been performed on this vehicle. The “Review Claim History” function will provide a listing of all claims against the vehicle. If this service action number appears in the program code field, do not perform this service action.



RE: S-514 Service Action – Closed Throttle Operation

JAGUAR CARS
555 MacARTHUR BOULEVARD
MAHWAH NJ 07430

Dear Jaguar Owner:

T 800 4 JAGUAR
www.jaguar.com

Jaguar Cars has identified a concern relating to the operation of the throttle body while in the closed position that may exist on the specific models listed below. If you are a recipient of this notice, and an owner of one of the vehicles within the VIN range, this letter is to inform you that your vehicle is included in this service action.

The following is a breakdown of the affected vehicles by model year, model and (VIN) range.

> 1997-1998	XK Vehicles	001036-031302
> 1998	XJ Vehicles Normally Aspirated Engine	812256-853935
> 1998-1999	XJ vehicles Supercharged Engine	812256-878717

What is the problem?

A concern has been identified with the throttle operation while in the closed position on a number of vehicles that could include your vehicle. Under exceptional circumstances this concern could cause the engine to cut out. If this occurs, the engine will continue to be driven by the road wheels through the transmission and there will be no loss of power steering, brakes, air conditioning, etc. The engine should restart without difficulty once the vehicle has come to a complete standstill.

This concern can be rectified by a modification to the throttle operation of your vehicle. Although it is most unlikely that you will have experienced this issue with the functionality of the throttle in your vehicle, Jaguar has determined that the engine management software that controls the throttle strategy does not meet our expected durability requirements.

What will Jaguar and your Dealer do?

Your vehicle will be repaired to modify the throttle operation at no charge to you.

What should you do?

At your earliest convenience you should contact your authorized Jaguar Dealer who will be able to make an appointment to undertake the necessary actions. To assist your Dealer please ensure that at the time of contact you have at hand your applicable Vehicle Identification Number.

The time to complete the repair on your vehicle is approximately one hour. However due to vehicle scheduling and the temperature of the engine, your Dealer may need to keep your vehicle longer to complete the repair.

Moved or no longer own a Jaguar?

Please fill out the enclosed card and return it to Jaguar by simply putting it in the mail.

Should you have the need to contact Jaguar by mail, please use the following address:

Jaguar Cars
ATTN: Customer Relationship Center
555 MacArthur Boulevard
Mahwah, NJ 07430-2327

Attention Leasing Agencies.

Please forward this Service Action notice to the lessee within 10 days.

What you should do if you have further questions?

Please contact your Jaguar Dealer or the Jaguar Customer Relationship Center at 1 800 4JAGUAR (1-800-452-4827), option 9 or by e-mail at jaguarowner@jaguar.com.

Sincerely,



Benjamin I. Weiner
Customer Satisfaction Manager