

1999 XK RANGE - Intake Air Distribution and Filtering - 303-12

4.  **CAUTION:**
Take care to avoid any coolant from dripping into supercharger.

Remove supercharger outlet duct.

1. Remove three bolts.
 2. Remove four bolts.
- Discard rubber seals from bolts.
 - 3. Remove outlet duct.
 - Discard outlet duct gasket.

5. Blank supercharger outlet with body tape, or similar, to prevent ingress of foreign matter.

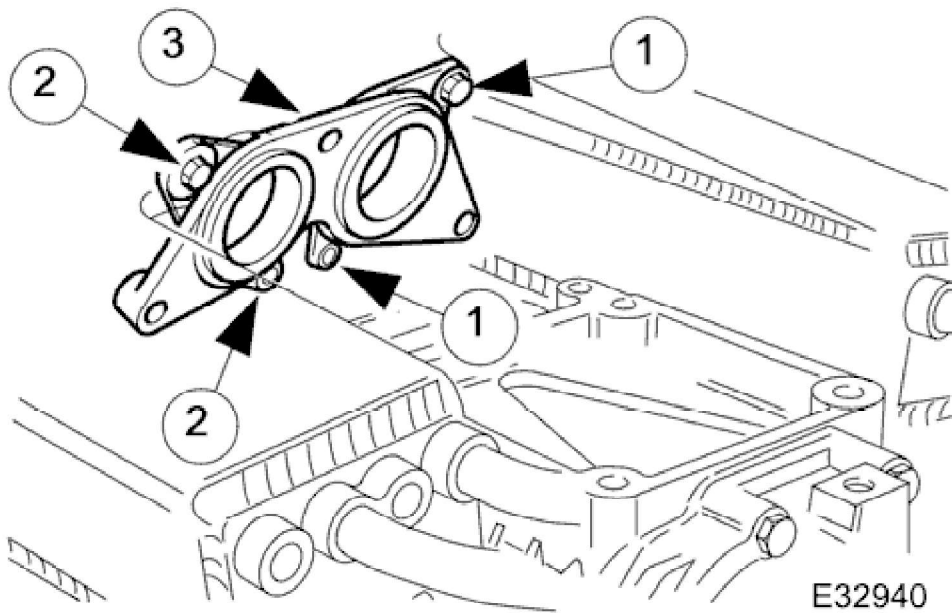

6. Remove charge air cooler inlet assembly.

1. Remove two bolts.
2. Remove two bolts.
3. Remove charge air cooler inlet assembly.

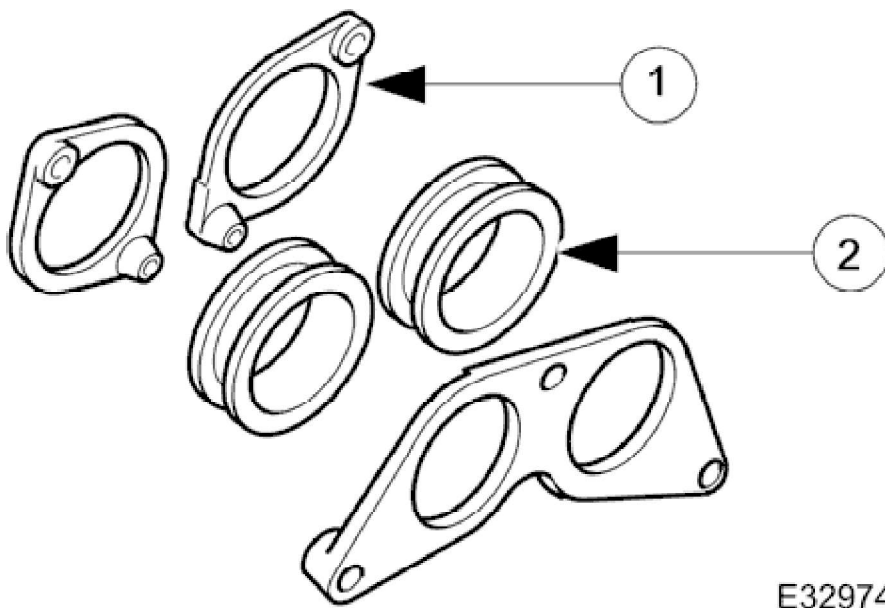

1999 XK RANGE - Intake Air Distribution and Filtering - 303-12

7. Remove ducts from charge air cooler inlet assembly.
 1. Remove two clamp plates.
 2. Discard two ducts.

8. Clean all relevant parts and mating faces.

Installation

1. Re-assemble charge air cooler clamp inlet assembly.
 - Use new ducts.

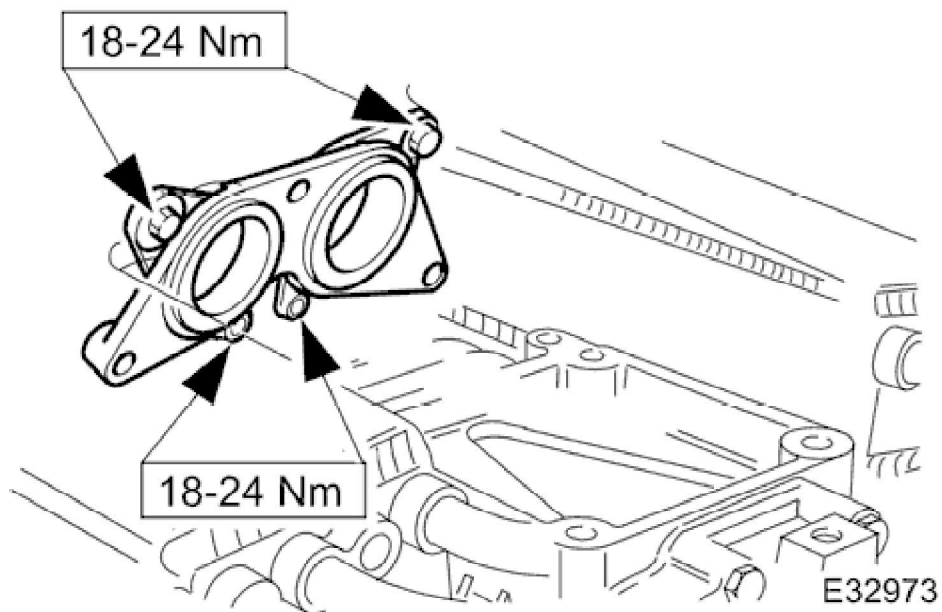

2. Install charge air cooler inlet assembly to charge air coolers.

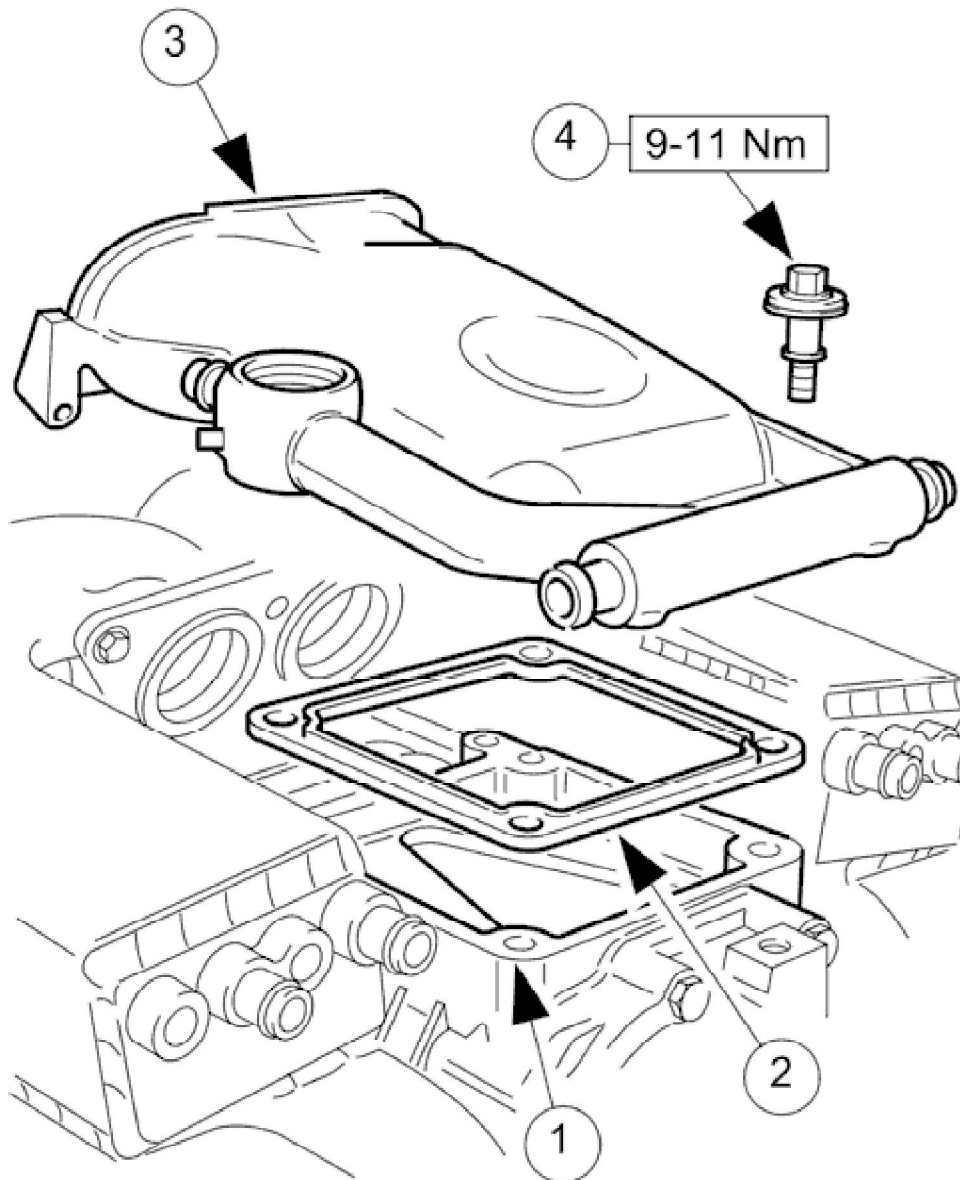

E32976

3.  **CAUTION:**
Take care to avoid ingress of dirt or foreign matter into the supercharger.

Install supercharger outlet duct.

1. Remove blanking tape from outlet port of supercharger.
- Clean supercharger outlet mating face.
2. Install new gasket.
3. Install duct.
4. Install new rubber seals to the four bolts.

1999 XK RANGE - Intake Air Distribution and Filtering - 303-12

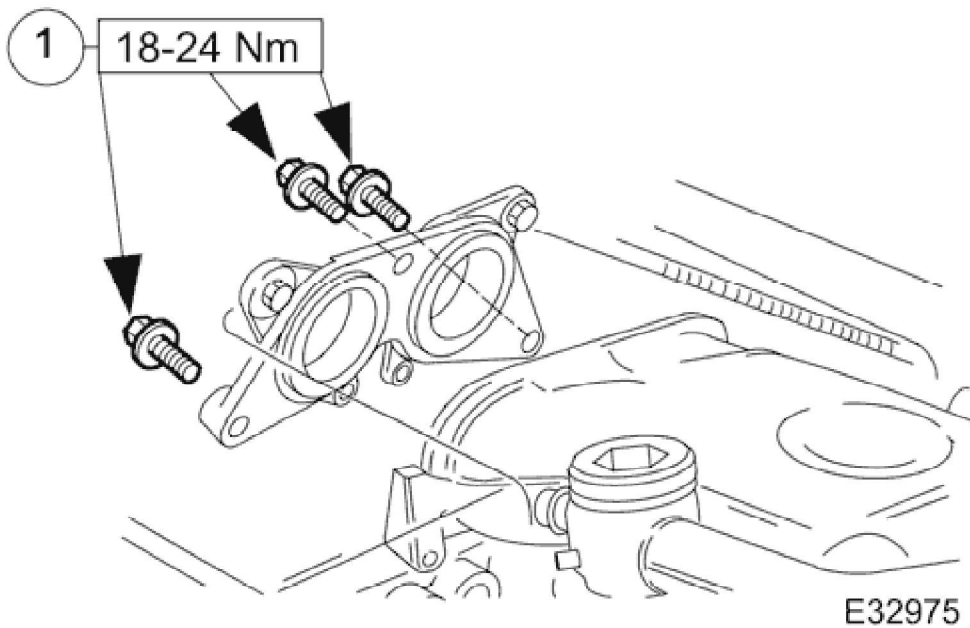

4. Secure charge air cooler inlet assembly to supercharger outlet duct.
1. Install bolts.

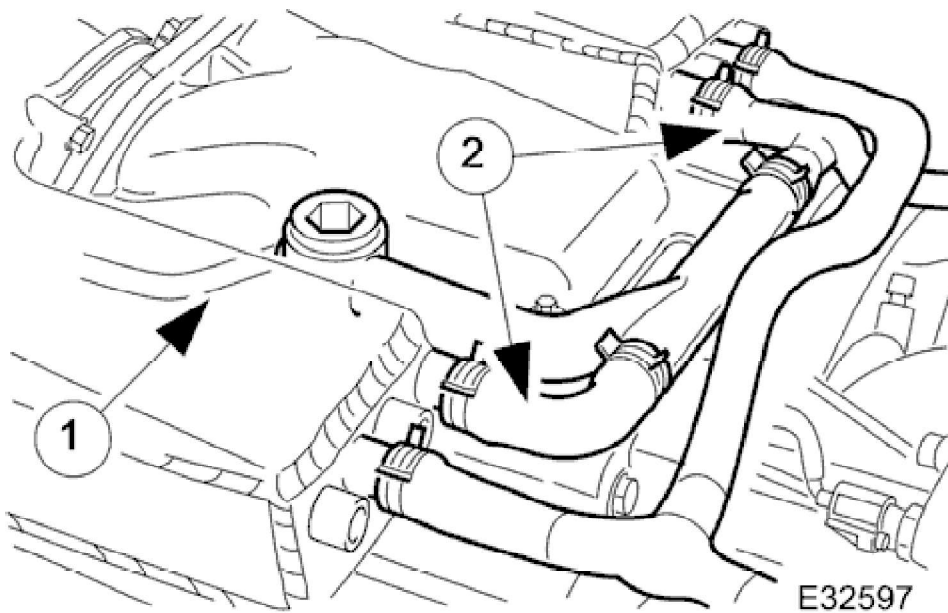

5. Install coolant hoses and vacuum pipe to outlet duct.
1. Install vacuum pipe.
2. Install coolant hoses.

6. Refill cooling system; refer to (SC) (26.10.01).

7. Install intake tube / air flow meter / air cleaner cover assembly; refer to 19.10.30.

1999 XK RANGE - Intake Air Distribution and Filtering - 303-12

Supercharger Outlet Pipe Gasket 18.50.17

Removal

1. Remove supercharger outlet duct; refer to <<18.50.16>>.

Installation

1. Installation is a reversal of the removal procedure.