



XK8

DATE 9/98

501-17

SERVICE

TECHNICAL BULLETIN

Water Ingress – Body Seams – Diagnosis

MODEL 1997 MY-ON
XK8 Range

VIN 001001-ON

Issue:

This bulletin provides information on areas to check if, following a customer complaint, it is suspected that water is entering a vehicle through a seam or opening.

Action:

In case of a customer complaint, the areas described in this procedure should be inspected, and where necessary modified, according to the following instructions.

The approved adhesives and sealers to be used in this procedure are listed under Parts Information at the end of the bulletin.

Illustration 1, on page 2, lists the areas of potential leaks in alphabetical order and these areas are then referred to, in the following pages, in that order.

LOCATIONS TO BE CHECKED

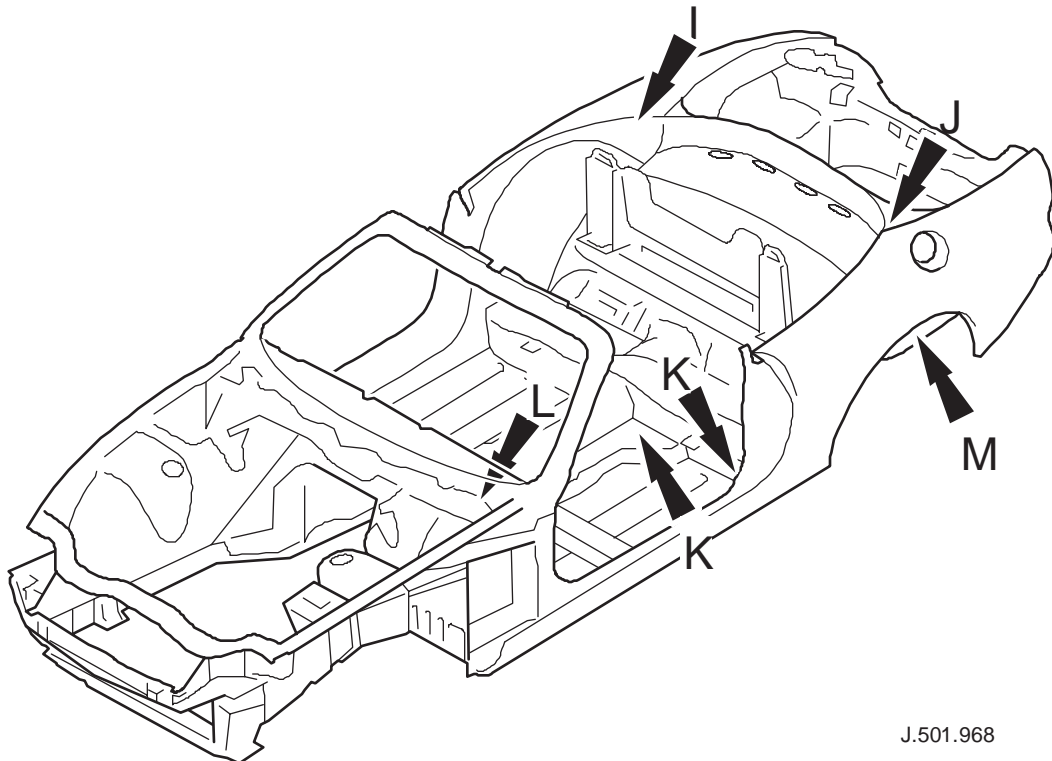
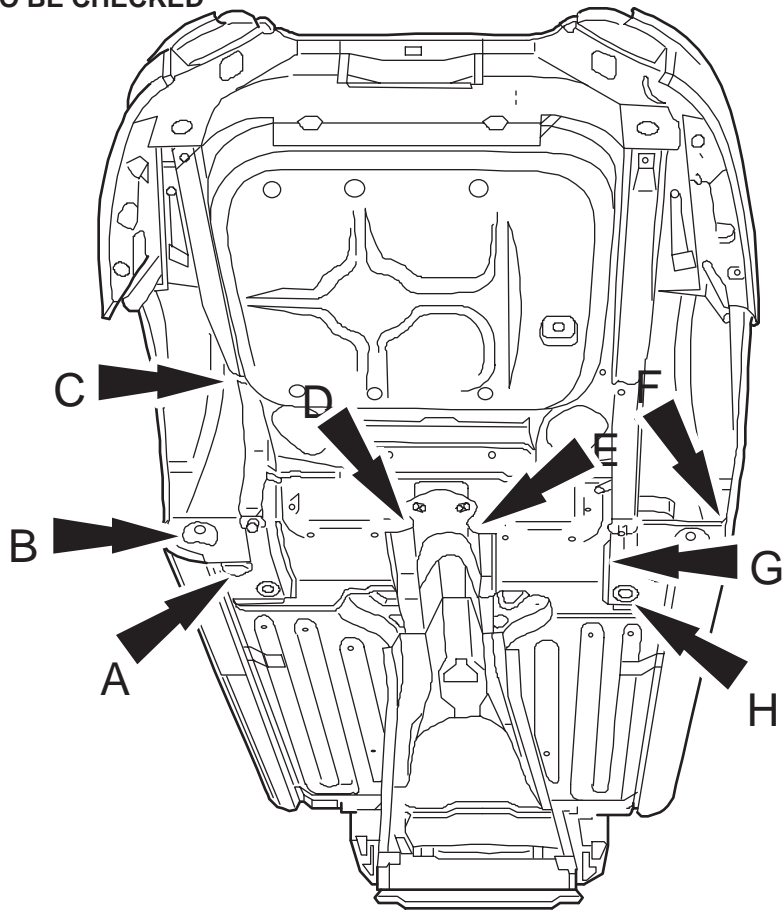

J.501.968

ILLUSTRATION 1

JUNCTION OF SILL AND REAR WHEEL WELL, LEFT-SIDE LOCATION A

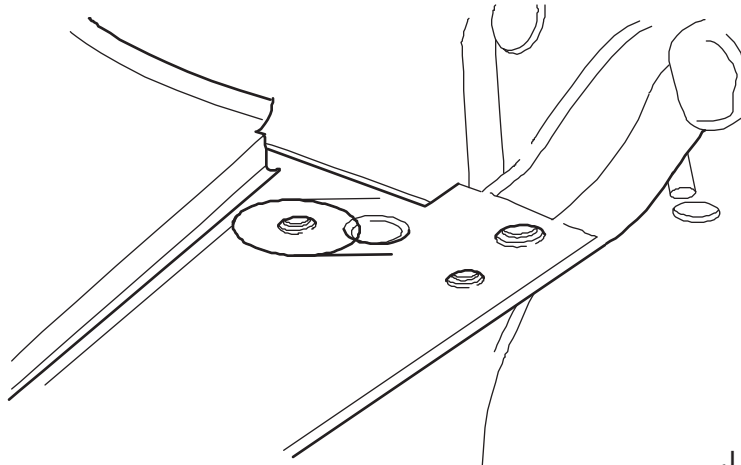

J.501.895

ILLUSTRATION 2

A. JUNCTION OF SILL AND REAR WHEEL WELL, LEFT-SIDE

Clean away any old sealant around the rear suspension mounting bolts.

Seal around the bolt head and the bracket and test.

If, after testing, further sealing is required, remove the bolts, clean around the bracket, install new bolts and then fully seal the area.

The above operation applies to both left and right sides

REARWHEEL WELL/SILL CLOSING PANEL, LEFT-SIDE LOCATION B

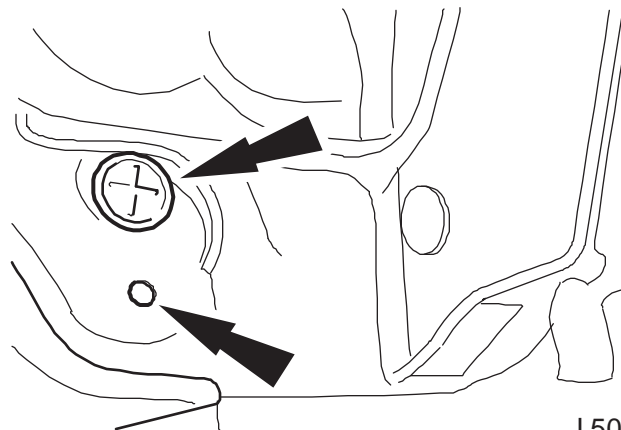

J.501.891

ILLUSTRATION 3

B. REAR WHEEL WELL/SILL CLOSING PANEL, LEFT-SIDE

Remove the large grommet, (upper arrow Illustration 3), and clean all the existing sealer from the grommet and the opening.

Replace the grommet, (replace, if necessary), and seal the grommet to the opening.

Identify the hole, (lower arrow Illustration 3) which is in the sill void area and through this hole fill the void with sealer.

The above operation applies to both left and right sides.

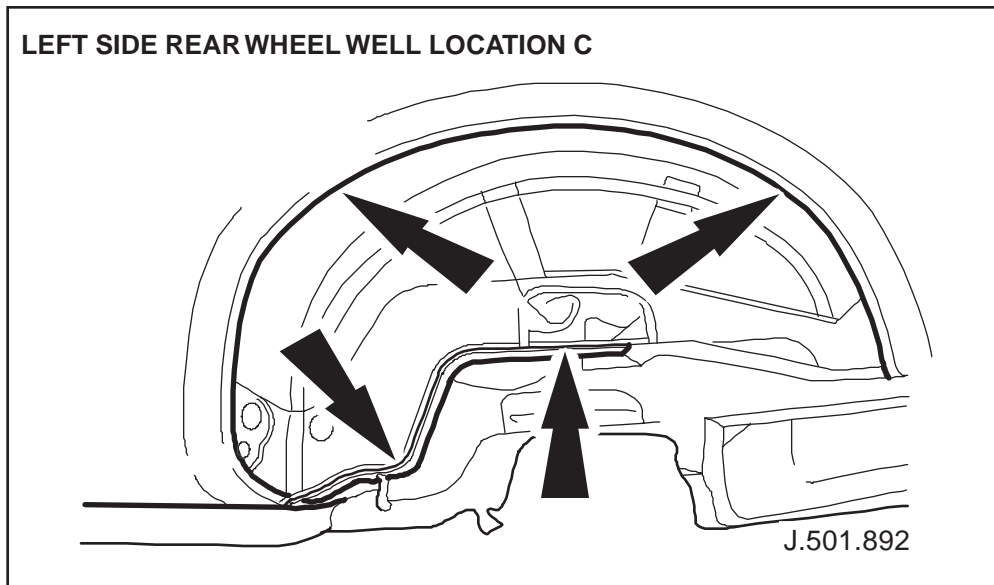

ILLUSTRATION 4

C. LEFT-SIDE REAR WHEEL WELL

Remove all old sealant from within and around the seam areas indicated in Illustration 4, and then check for possible leakage in these areas by applying air pressure behind the seams.

Apply a two pack adhesive/sealer to the seams, (see the next section for information on sealing the luggage compartment side of the wheel well seam).

The above operation applies to both left and right sides.

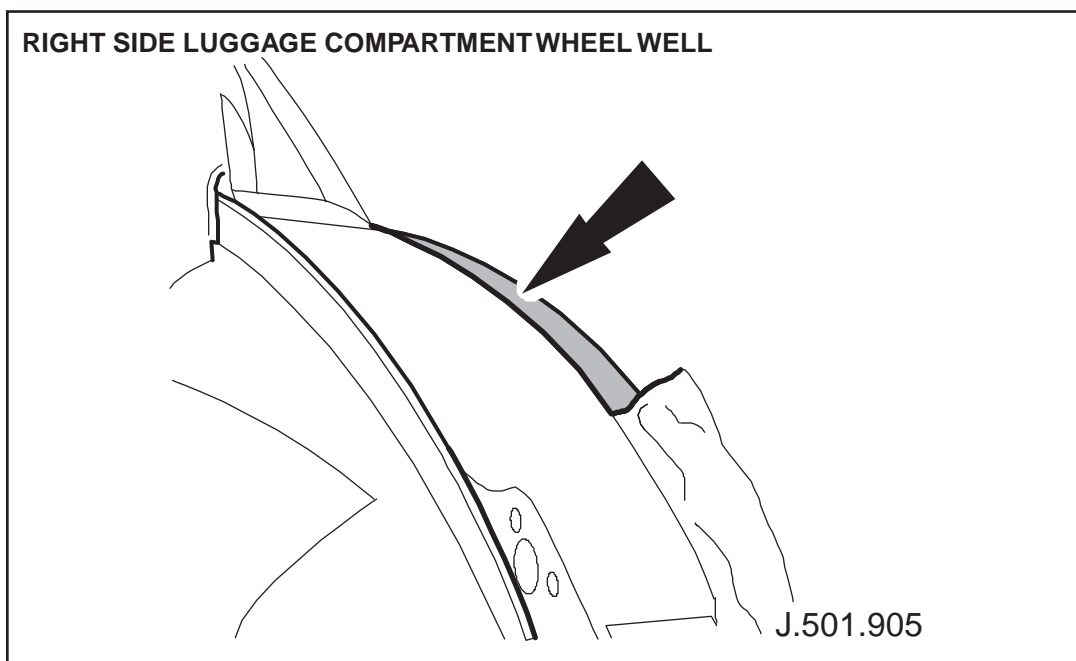

ILLUSTRATION 5

RIGHT-SIDE LUGGAGE COMPARTMENT WHEEL WELL

From within the luggage compartment, remove any sealer that lies in the seam between the wheel well and the outer skin, (shown shaded in Illustration 5).

Fill the whole length of the seam with adhesive/sealer.

The above operation applies to both left and right sides.

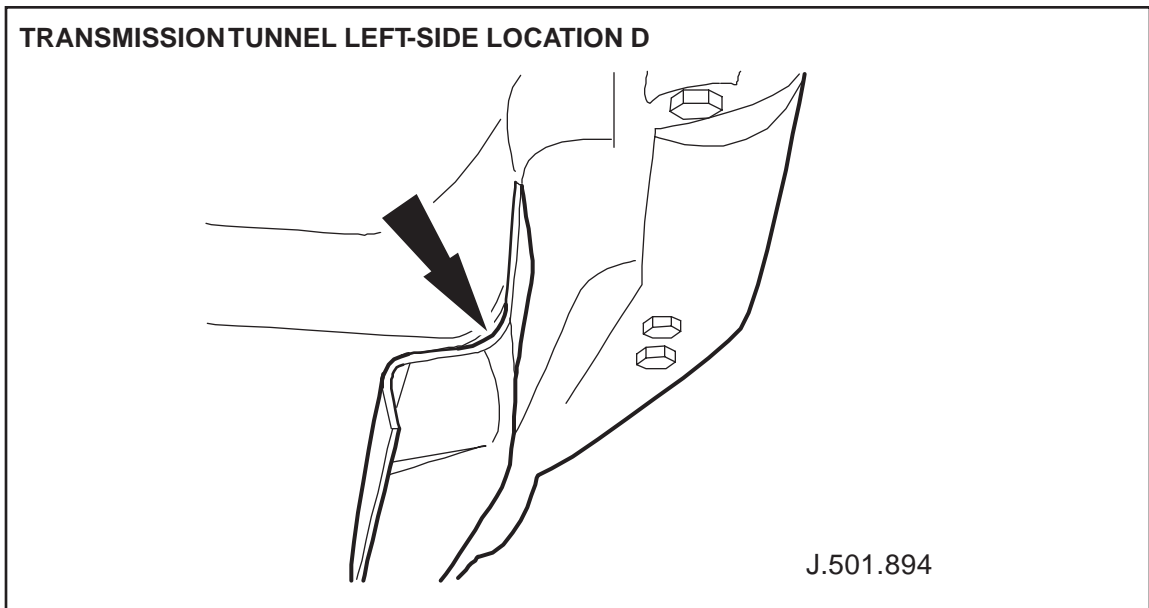

ILLUSTRATION 6

D. TRANSMISSION TUNNEL LEFT-SIDE

Using a suitable tool, probe the seam between the floor panel and the transmission tunnel, (arrowed in Illustration 6), to remove all the existing sealing material.

When the seam has been cleaned of all sealing debris, fully seal the area with adhesive/sealer. Check the seal with air pressure.

The above operation applies to both left and right sides.

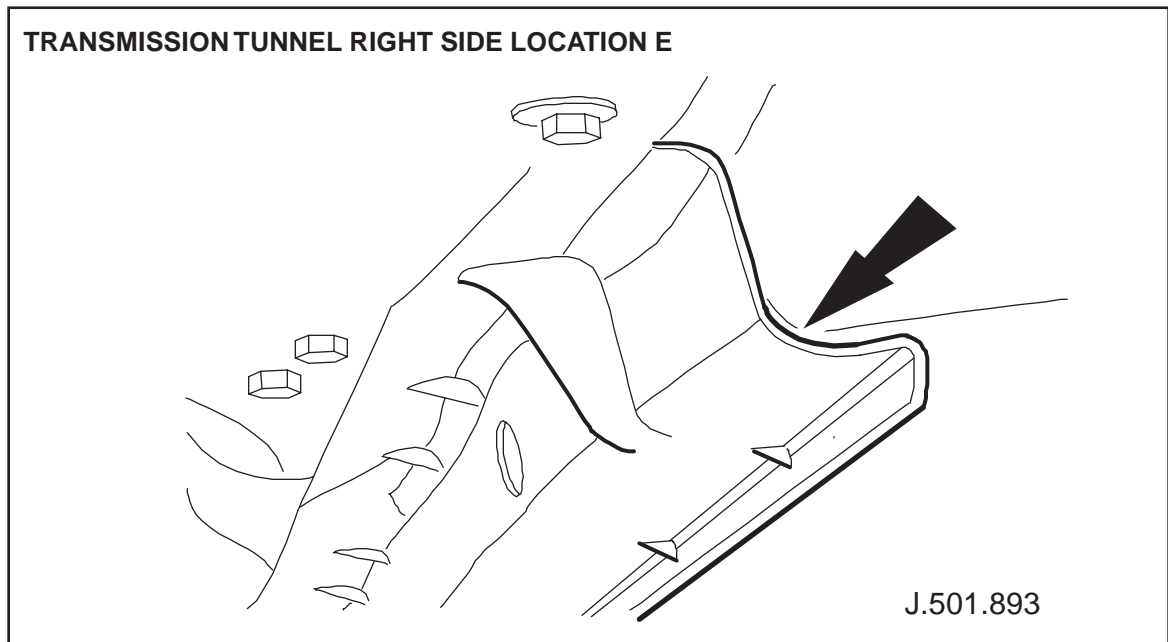

ILLUSTRATION 7

E. TRANSMISSION TUNNEL RIGHT SIDE

Clean and seal this area as with area D. (Illustration 6).

The above operation applies to both left and right sides.

REAR INNER WHEEL WELL, FRONT EDGE LOCATION F

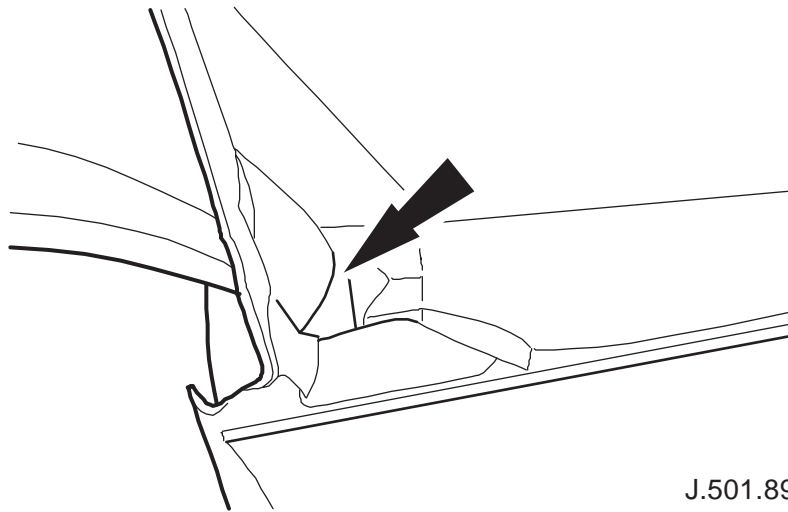

J.501.897

ILLUSTRATION 8

F. REAR INNER WHEEL WELL, FRONT EDGE

Clean and seal this area, (Illustration 6).

The above operation applies to both left and right sides.

LEFT-SIDE UNDER FOOTWELL LOCATION G

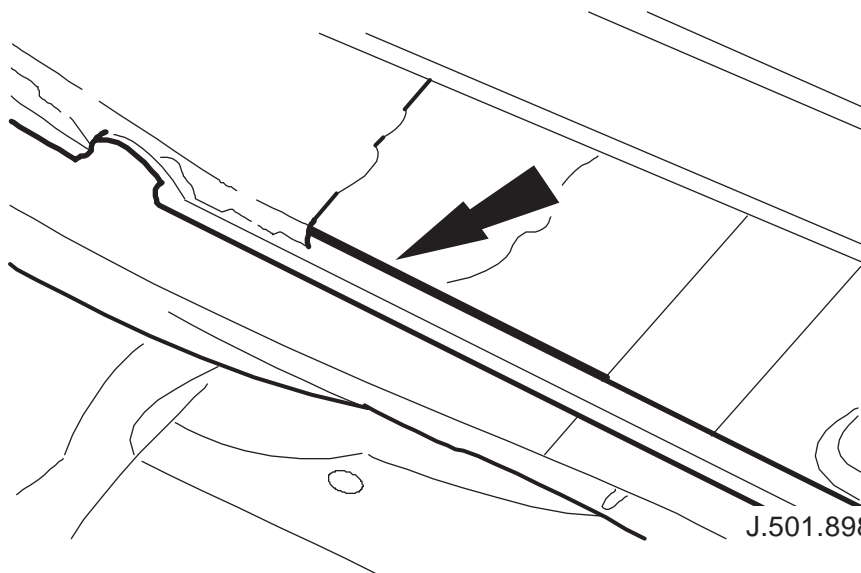

J.501.898

ILLUSTRATION 9

G. LEFT-SIDE UNDER FOOTWELL

The sill to floor seam, indicated by the arrow, should be inspected for any gap in the seal.

If a break or gap is discovered, the sealing material in that area should be removed and the area resealed.

The above operation applies to both left and right sides.

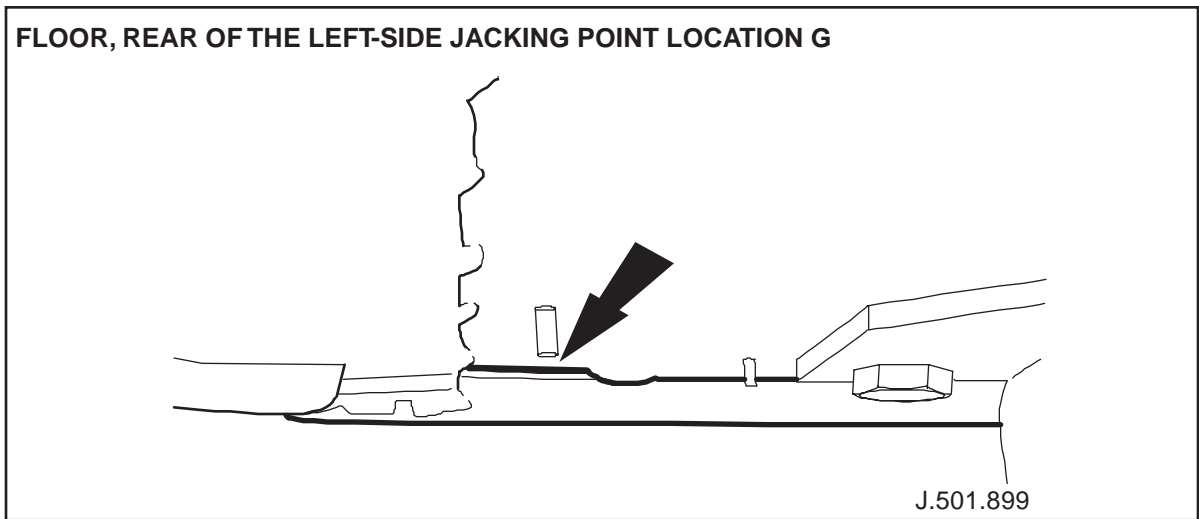

ILLUSTRATION 10

G. FLOOR, REAR OF THE LEFT-SIDE JACKING POINT

The seam, indicated by the arrow, should be inspected for any gap in the seal.

If a break or gap is discovered, the sealing material in that area should be removed and the area resealed.

The above operation applies to both left and right sides.

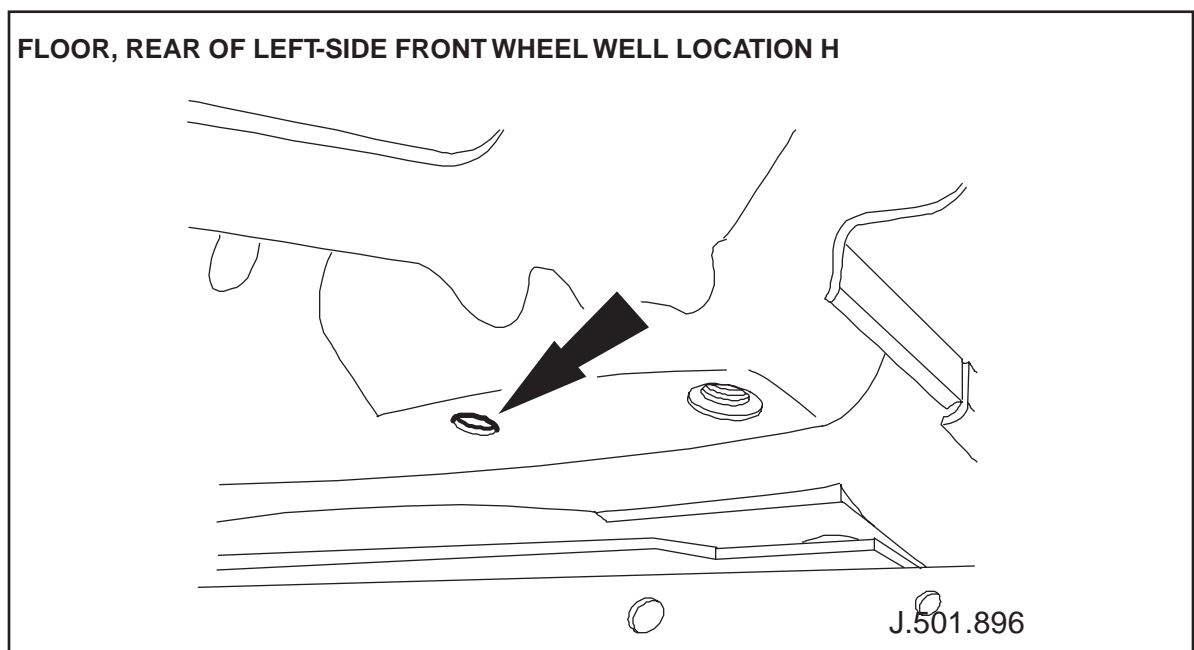

ILLUSTRATION 11

H. FLOOR, REAR OF LEFT-SIDE FRONT WHEEL WELL

Inspect the hole indicated by the arrow. Clear out any debris and fill with sealant.

The above operation applies to both left and right sides.

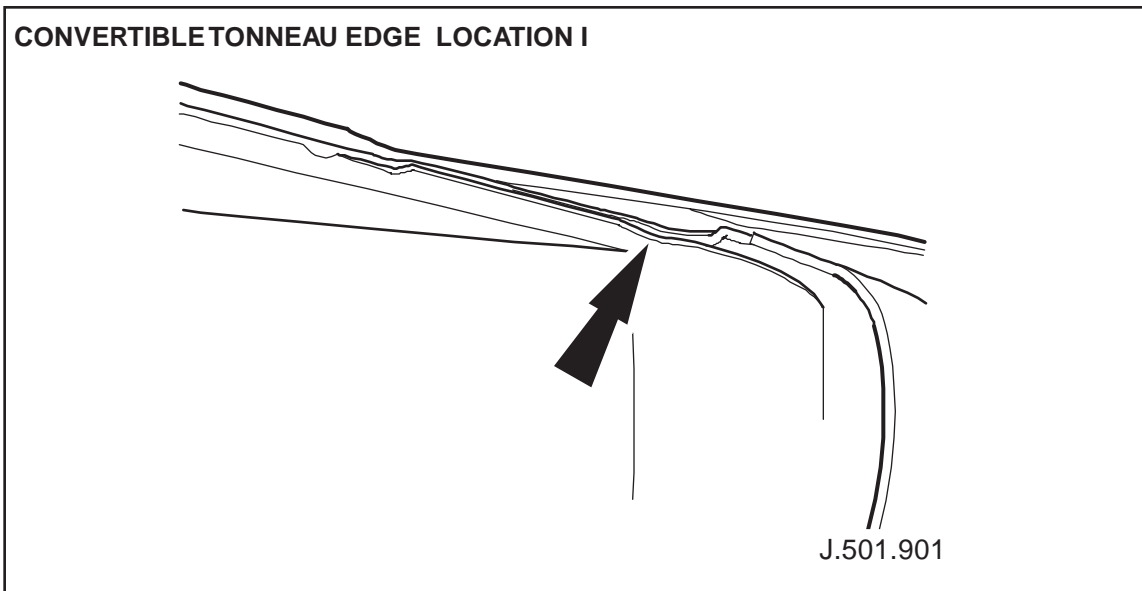

ILLUSTRATION 12

I. CONVERTIBLE TONNEAU EDGE

Clear out any debris and fill with sealant.

The above operation applies to both left and right sides.

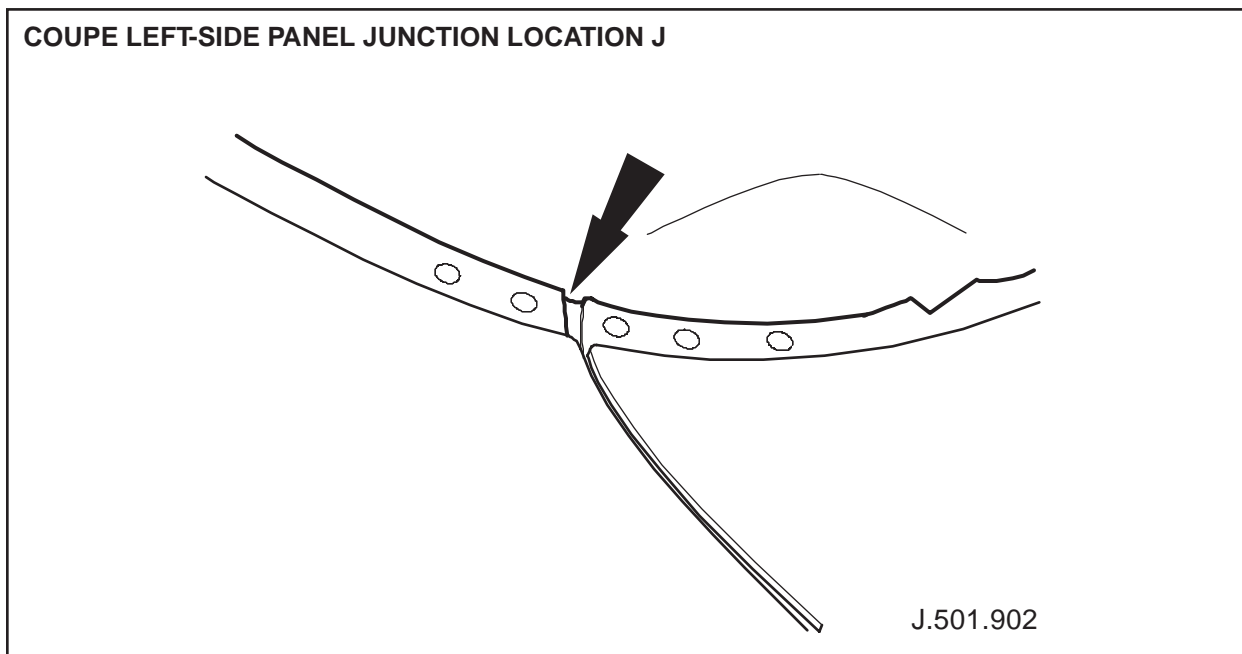

ILLUSTRATION 13

J. COUPE LEFT-SIDE PANEL JUNCTION, REAR GLASS MOUNTING FLANGE

If water is leaking into the luggage compartment this area should be inspected.

If this area is proved to be the source of the leak, the rear glass must be removed, the gap, (arrowed in Illustration 13), filled with glass sealer adhesive and the glass reinstalled.

The above operation applies to both left and right sides.

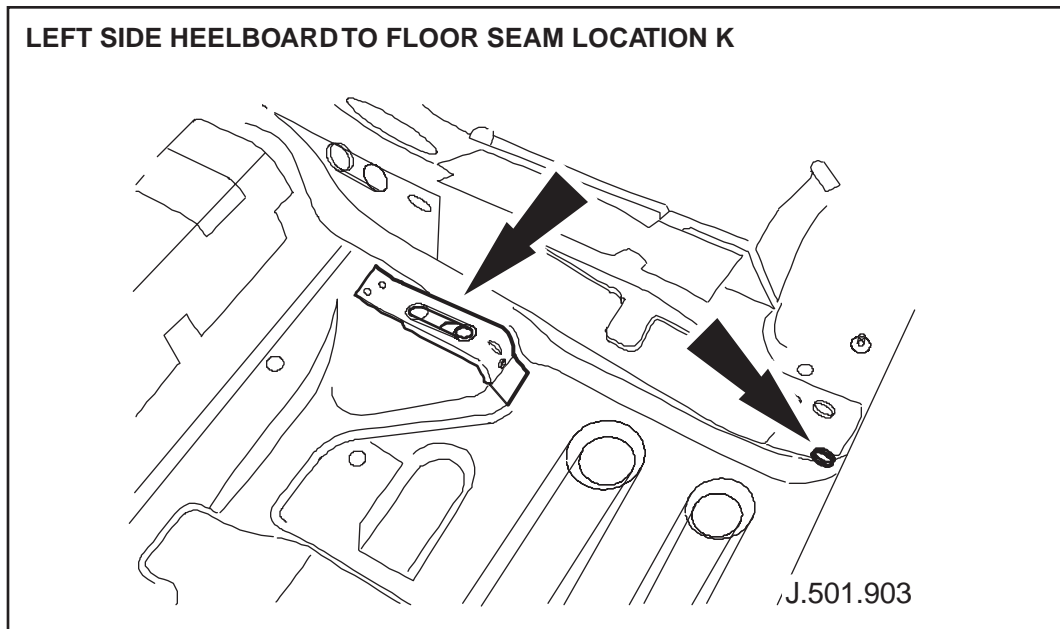

ILLUSTRATION 14

K. LEFT SIDE HEELBOARD TO FLOOR SEAM LOCATION

Inspect the seam indicated by the arrows and, if there is evidence of a water leak, remove the existing sealant and fill the seam with sealant.

The above operation applies to both left and right sides of the floor and the transmission tunnel.

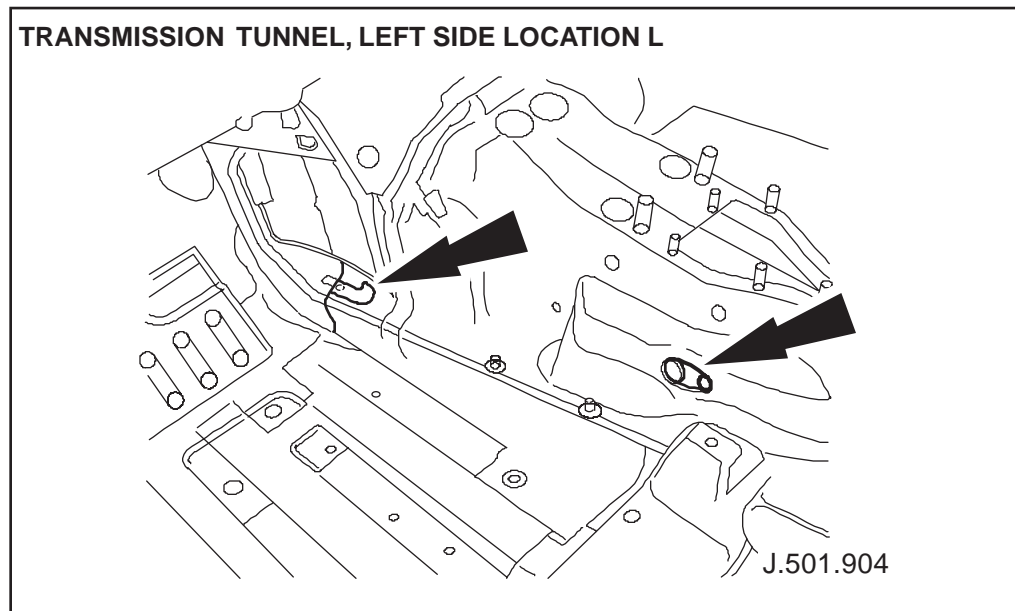

ILLUSTRATION 15

L. TRANSMISSION TUNNEL, LEFT SIDE LOCATION

Inspect the selector lever cable grommet, indicated by the arrow and if there is evidence of a leak, remove the grommet, clean off all sealant from the grommet and the body, replace the grommet in position in the body aperture and then seal the area.

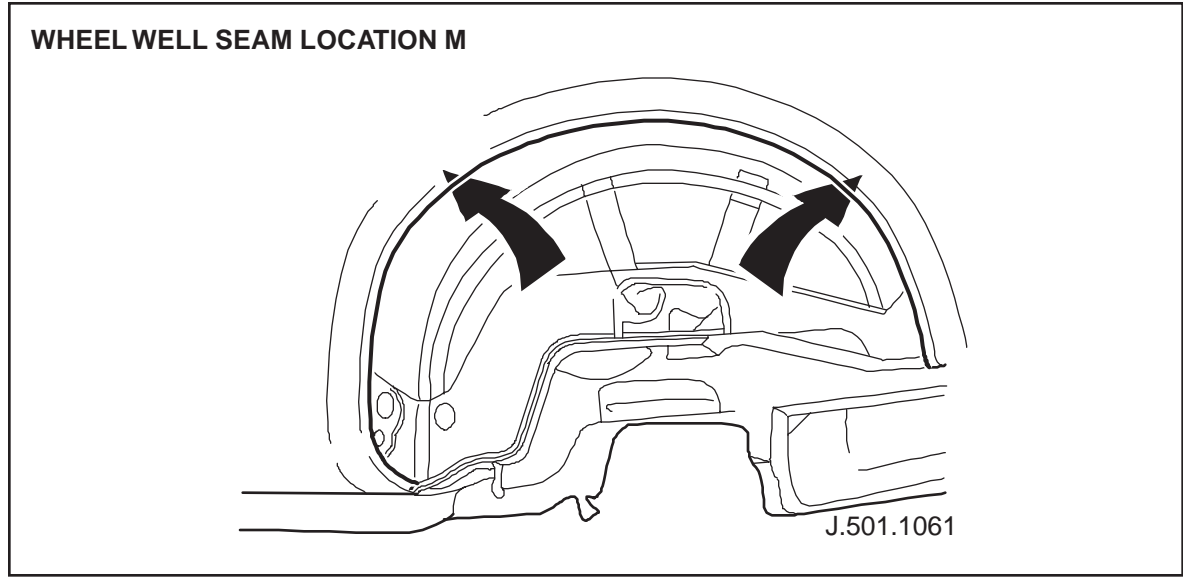

ILLUSTRATION 16

M. WHEEL WELL SEAM

Inspect the area around the wheel well, between the inner and outer panels, indicated by the arrows. Clear out any debris and fill with sealant.

The above operation applies to both left and right sides.

Parts Information:

Jaguar approved materials

<u>MANUFACTURER</u>	<u>MATERIAL</u>	<u>QTY</u>	<u>PART NUMBER</u>
3M	Panel bonding adhesive	310ml	08115
	Ultrapro urethane seam sealer	310ml	08360
	Flexseal sealer	310 ml	08405
	Auto sealer	310 ml	08500
	Auto joint and seam sealer	310 ml	08646
Kent	Quick seal 325	290 ml	08648
	Leak chek clear	220 ml, 8 oz.	10556
	Leak chek clear	325 ml, 11 oz.	10500
			30040

Warranty Information:

This bulletin is for technical information purposes only.