

Camshaft Position (CMP) Sensor LH Vehicles Without: Supercharger 18.31.12

Special Service tools

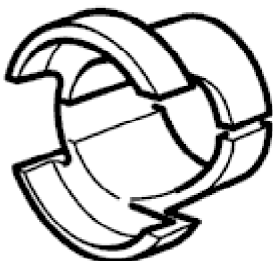



E36393

Quick Fit Connector Release Tool
310-044

Removal  **WARNING:**
PLACE THE VEHICLE IN A QUARANTINED AREA AND ARRANGE 'NO SMOKING/PETROL FUMES'
SIGNS ABOUT THE VEHICLE.

 **WARNING:**
BEFORE ANY WORK IS CARRIED OUT ON THE FUEL SYSTEM, GROUND THE VEHICLE TO EARTH
AND MAINTAIN THE GROUND CONNECTION UNTIL THE WORK IS COMPLETE.

 **WARNING:**
DO NOT SMOKE OR CARRY LIGHTED TOBACCO OR OPEN FLAME OF ANY TYPE WHEN WORKING ON
OR NEAR ANY FUEL RELATED COMPONENTS. HIGHLY FLAMMABLE VAPORS ARE ALWAYS
PRESENT AND MAY IGNITE. FAILURE TO FOLLOW THESE INSTRUCTIONS MAY RESULT IN
PERSONAL INJURY.

 **WARNING:**
THE FUEL SYSTEM REMAINS PRESSURIZED FOR A LONG TIME AFTER THE IGNITION IS SWITCHED
OFF. THE FUEL PRESSURE MUST BE RELEASED BEFORE ATTEMPTING ANY REPAIRS. FAILURE TO
FOLLOW THESE INSTRUCTIONS MAY RESULT IN PERSONAL INJURY.

 **WARNING:**
AFTER CARRYING OUT REPAIRS, THE FUEL SYSTEM MUST BE CHECKED VISUALLY FOR LEAKS.
FAILURE TO FOLLOW THESE INSTRUCTIONS MAY RESULT IN PERSONAL INJURY.

 **WARNING:**
THIS PROCEDURE INVOLVES FUEL HANDLING. BE PREPARED FOR FUEL SPILLAGE AT ALL TIMES
AND ALWAYS OBSERVE FUEL HANDLING PRECAUTIONS. FAILURE TO FOLLOW THESE
INSTRUCTIONS MAY RESULT IN PERSONAL INJURY.

 **WARNING:**
IF FUEL IS TAKEN INTERNALLY DO NOT INDUCE VOMITING, SEEK IMMEDIATE MEDICAL ATTENTION.
FAILURE TO FOLLOW THESE INSTRUCTIONS MAY RESULT IN PERSONAL INJURY.

2000 XK RANGE - Electronic Engine Controls - 303-14



WARNING:
IF FUEL CONTACTS THE EYES, FLUSH THE EYES WITH COLD WATER OR EYEWASH SOLUTION AND SEEK MEDICAL ATTENTION.



WARNING:
WASH HANDS THOROUGHLY AFTER HANDLING, AS PROLONGED CONTACT MAY CAUSE IRRITATION. SHOULD IRRITATION DEVELOP, SEEK MEDICAL ATTENTION.



WARNING:
DO NOT CARRY OR OPERATE CELLULAR PHONES WHEN WORKING ON OR NEAR ANY FUEL RELATED COMPONENTS. HIGHLY FLAMMABLE VAPORS ARE ALWAYS PRESENT AND MAY IGNITE. FAILURE TO FOLLOW THESE INSTRUCTIONS MAY RESULT IN PERSONAL INJURY.

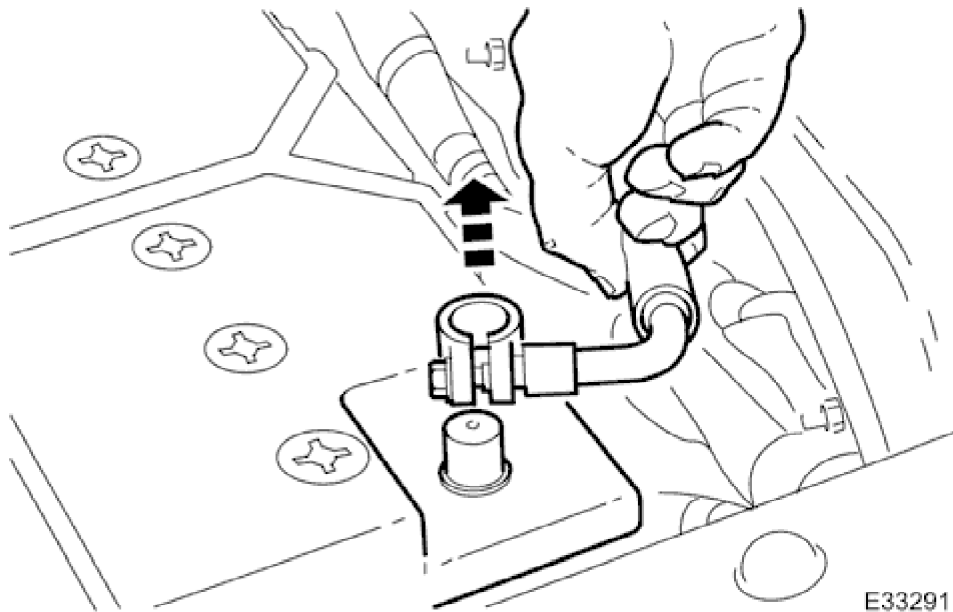

1. Disconnect the battery ground cable.
 - Remove the battery cover.
2. Release the fuel system pressure. <<310-00>>

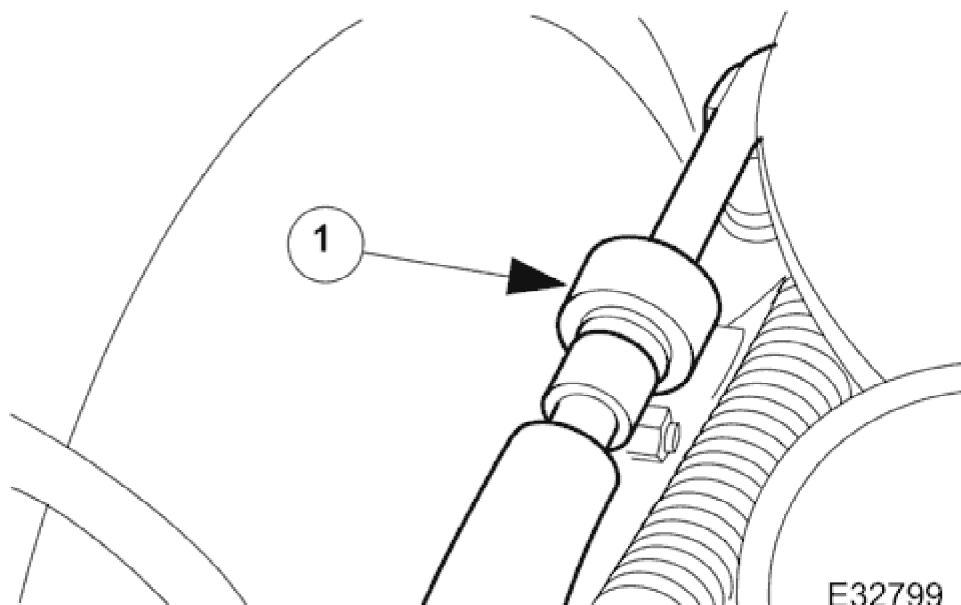

3. **NOTE:**

Place an absorbent cloth under the fuel connection to absorb any spillages.

NOTE:

Cap the fuel line and fuel injection supply manifold to prevent contamination.

Disconnect the fuel feed hose.

1. Disconnect the fuel feed hose at the Quick Fit connector, using special tool 310 - 044.

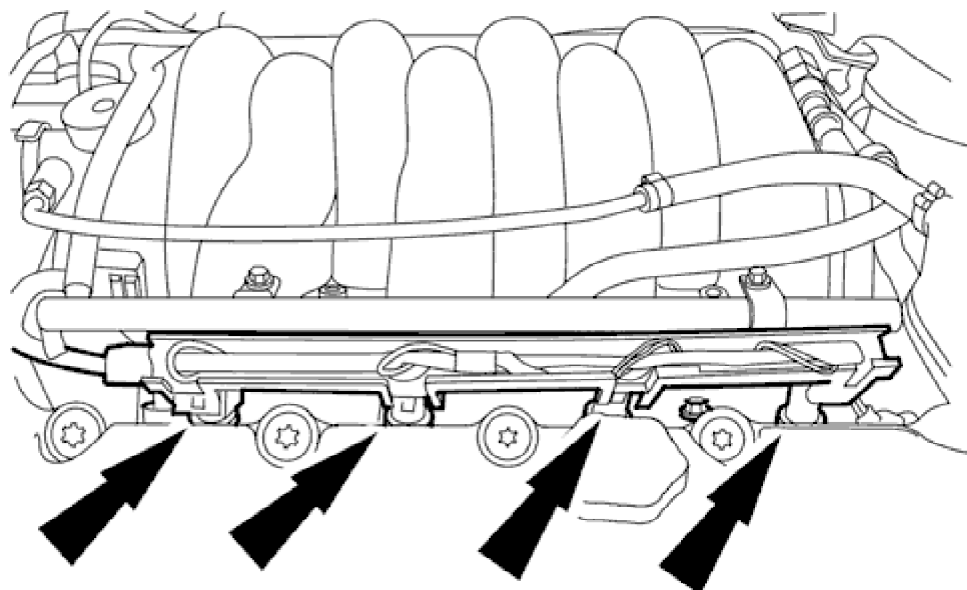

4. Disconnect the left-hand fuel injectors electrical connectors.

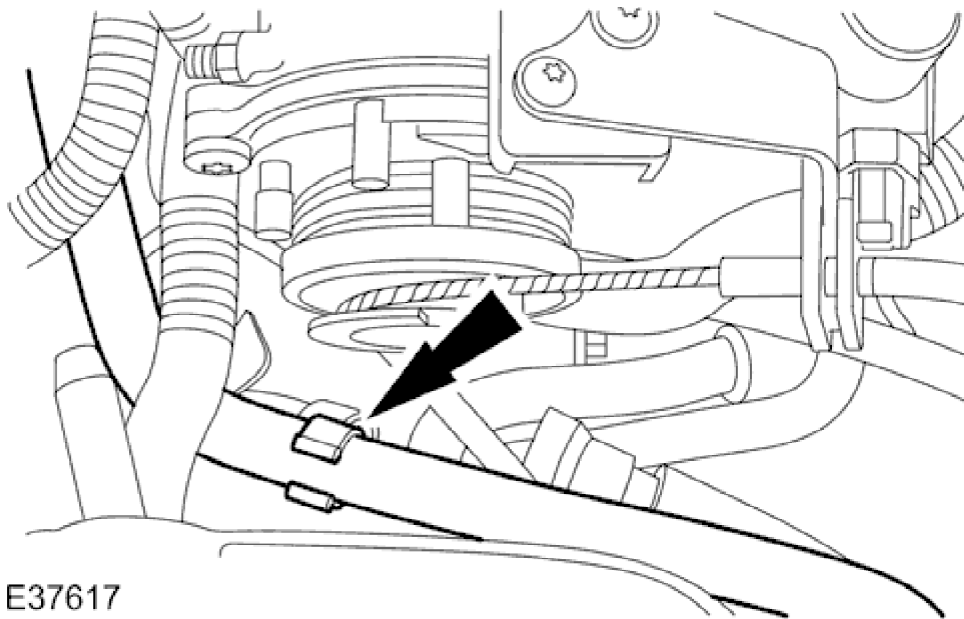

E37617

5. Detach the fuel injector supply manifold from the retaining clip.

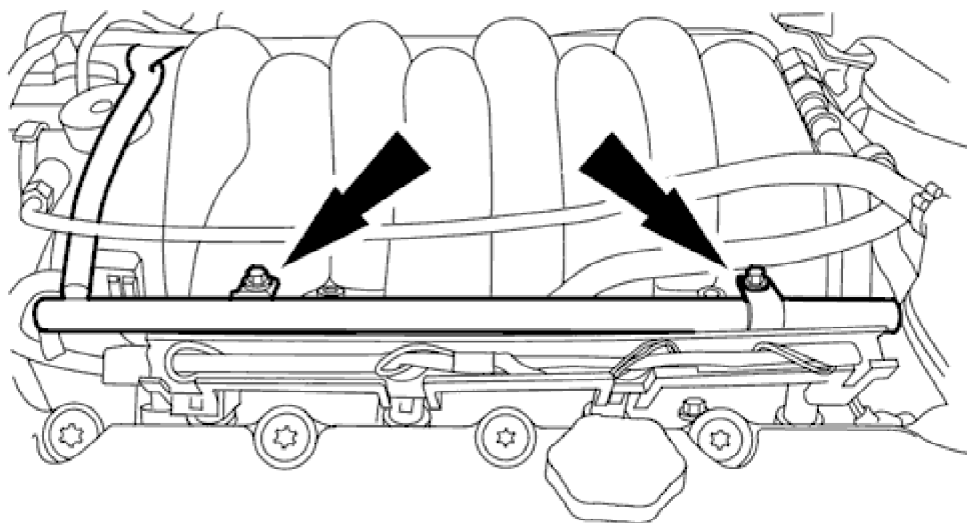

E37583

6. Detach the fuel injector supply manifold from the intake manifold.

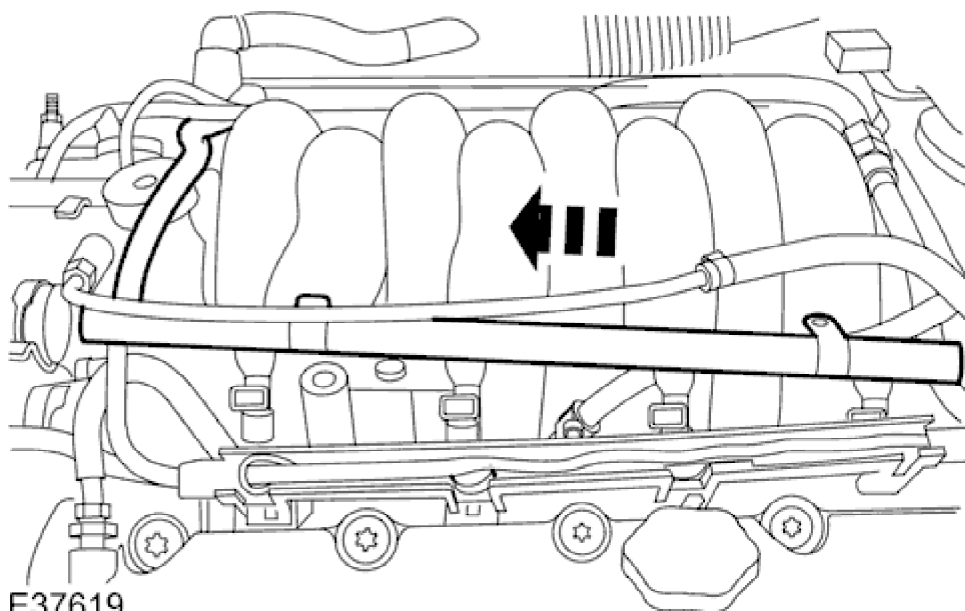

E37619

7. **NOTE:**

Cap the intake manifold injector ports.

Reposition the fuel injector supply manifold.

- Remove and discard the fuel injector O-ring seals.

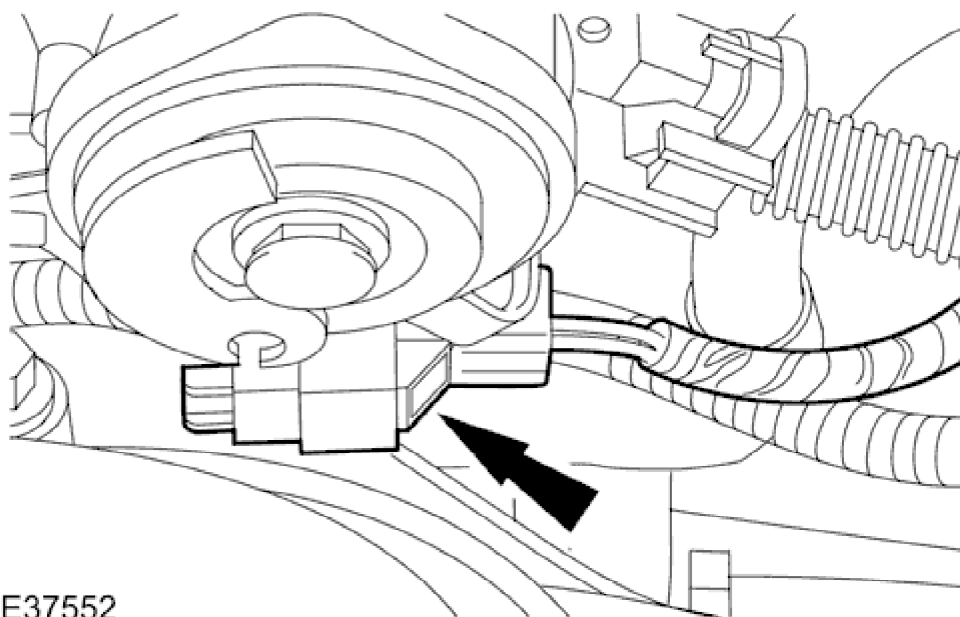

E37552

8. Detach the camshaft position (CMP) sensor wiring harness from the throttle body elbow.

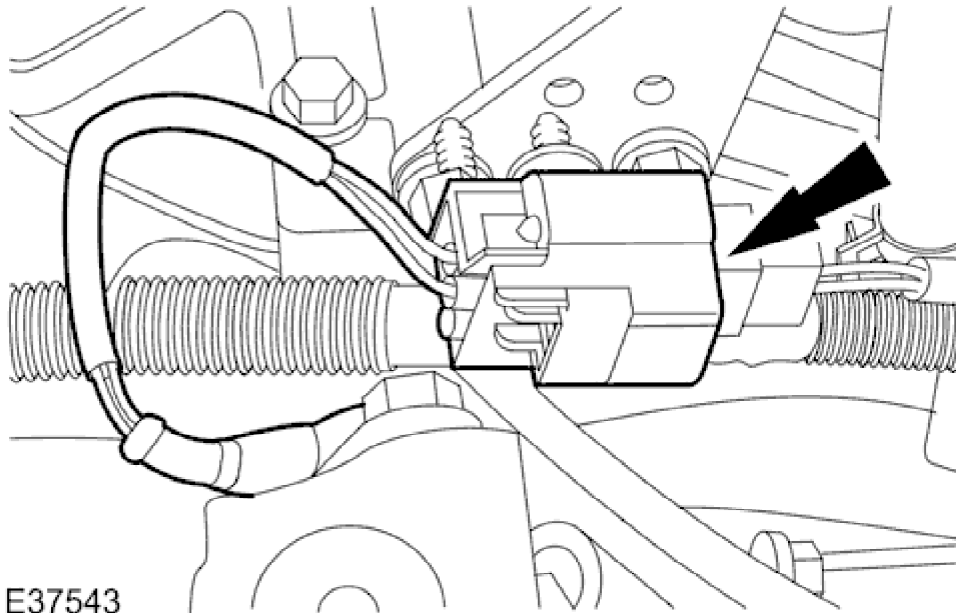

E37543

9. Disconnect the CMP sensor electrical connector.

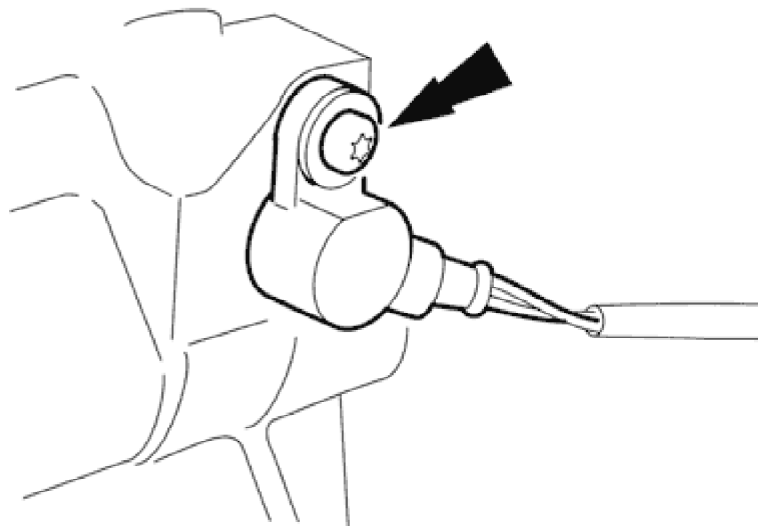

E37618

10. Remove the CMP sensor.

Installation

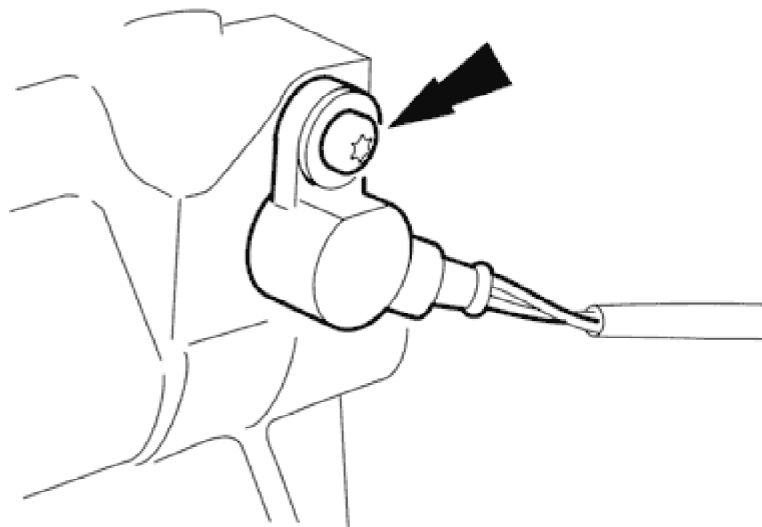

E37618

1. Install the CMP sensor.
 - Tighten to 7 Nm.

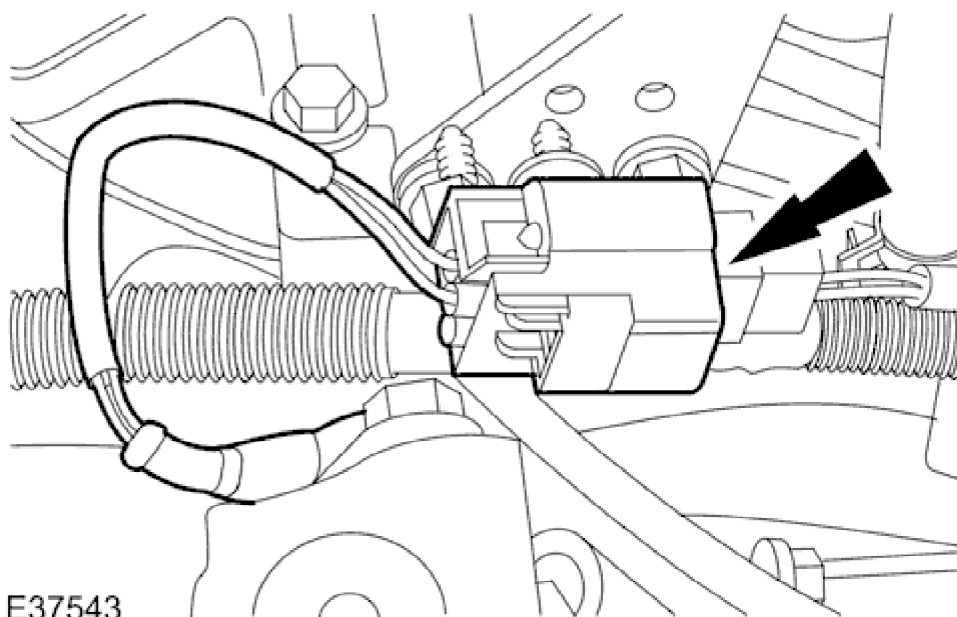

E37543

2. Connect the CMP sensor electrical connector.

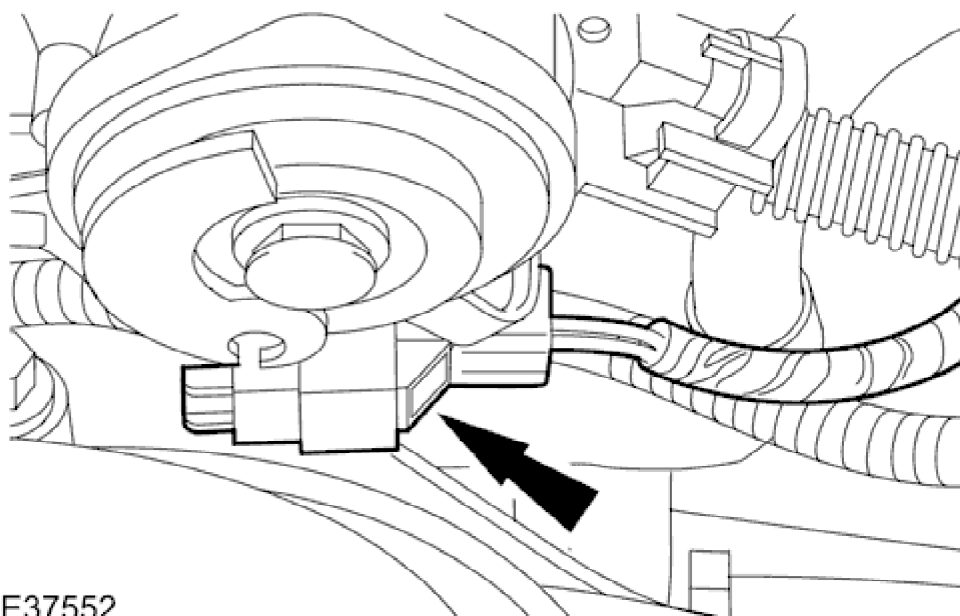

E37552

3. Attach the CMP sensor wiring harness to the throttle body elbow.

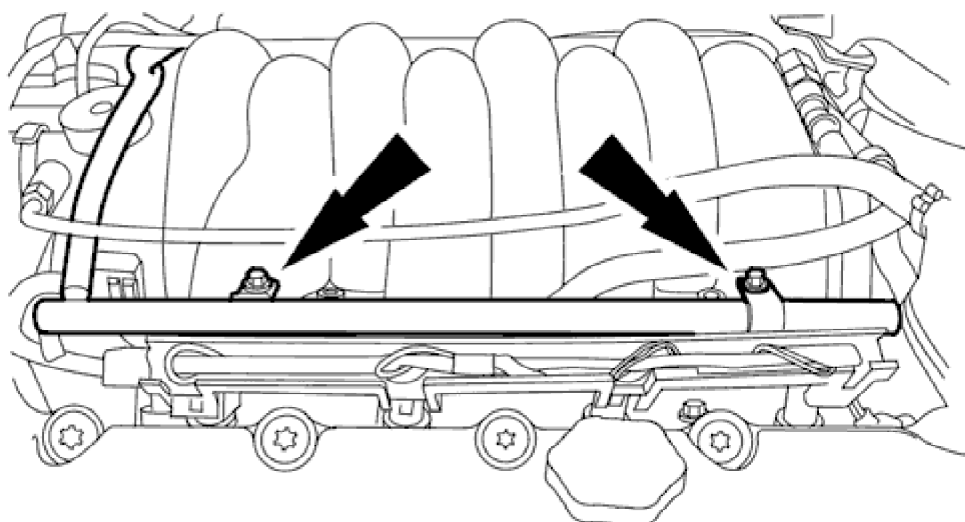

E37583

4.  **CAUTION:**
Make sure the fuel injectors are correctly installed to the intake manifold. Failure to follow these instructions may result in damage to the vehicle.

NOTE:
Install new fuel injector O-ring seals.

Install the fuel injection supply manifold.

- Tighten to 12 Nm.

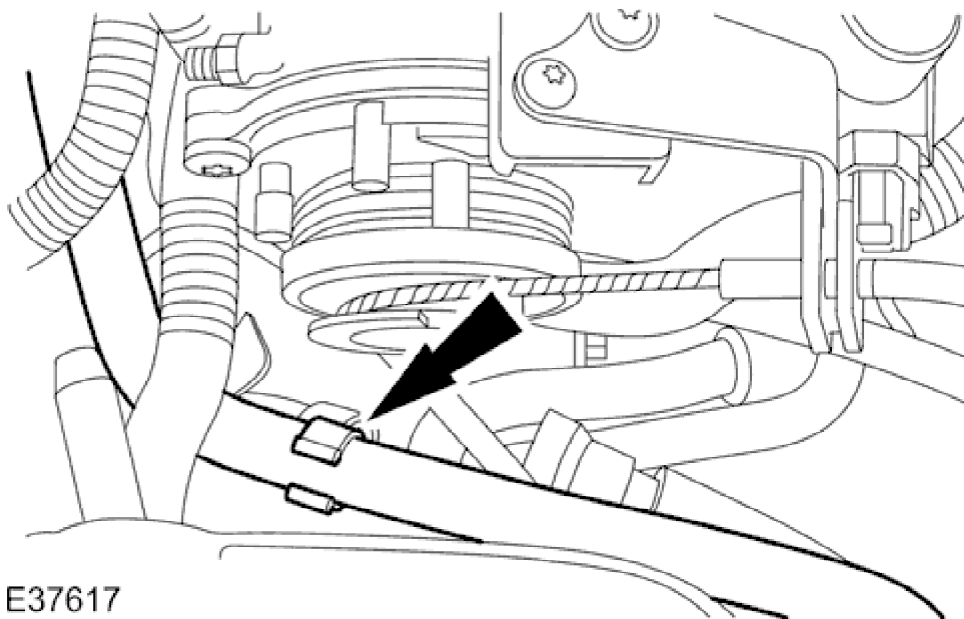

E37617

5. Attach the fuel injector supply manifold to the retaining clip.

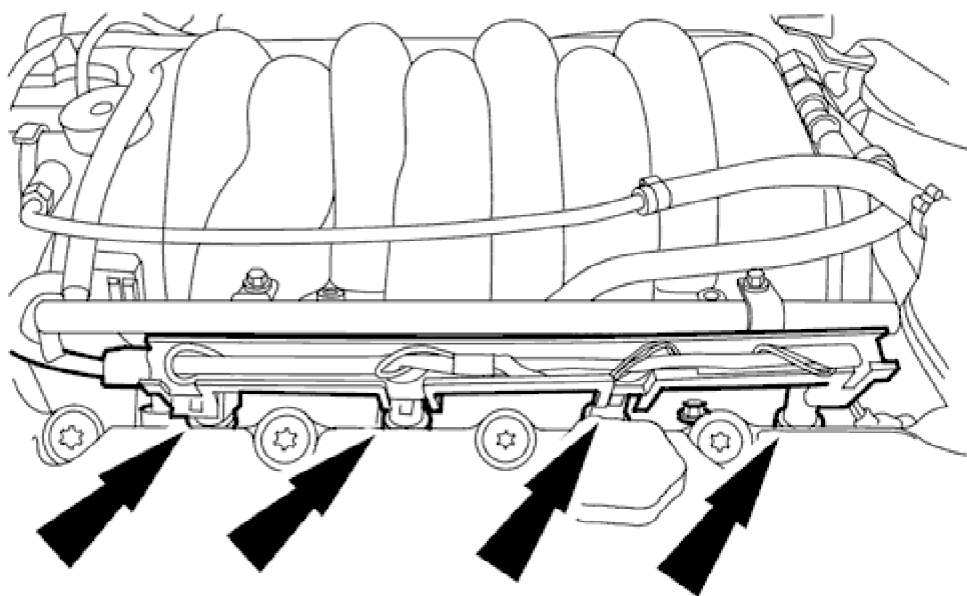

E37582

6. Connect the left-hand fuel injectors electrical connectors.

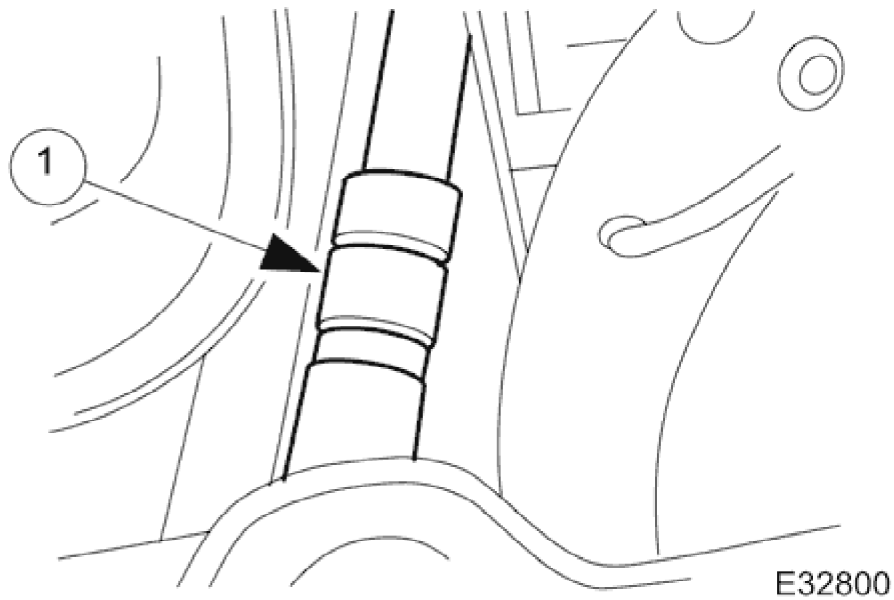

7. **NOTE:**
Uncap the fuel line and fuel injection supply manifold.

NOTE:
Remove and dispose of absorbent cloth whilst complying to local health and safety standards.

Connect the fuel feed hose.

1. Connect the fuel feed hose at the Quick Fit connector. Ensure that the hose is fully seated to the feed pipe.
8. Carry out the battery reconnection procedure. <<414-01>>