

1999 XK RANGE - Electronic Engine Controls - 303-14

Electronic Engine Controls

Engine Sensors

Vehicles Without Supercharger

1999 XK RANGE - Electronic Engine Controls - 303-14

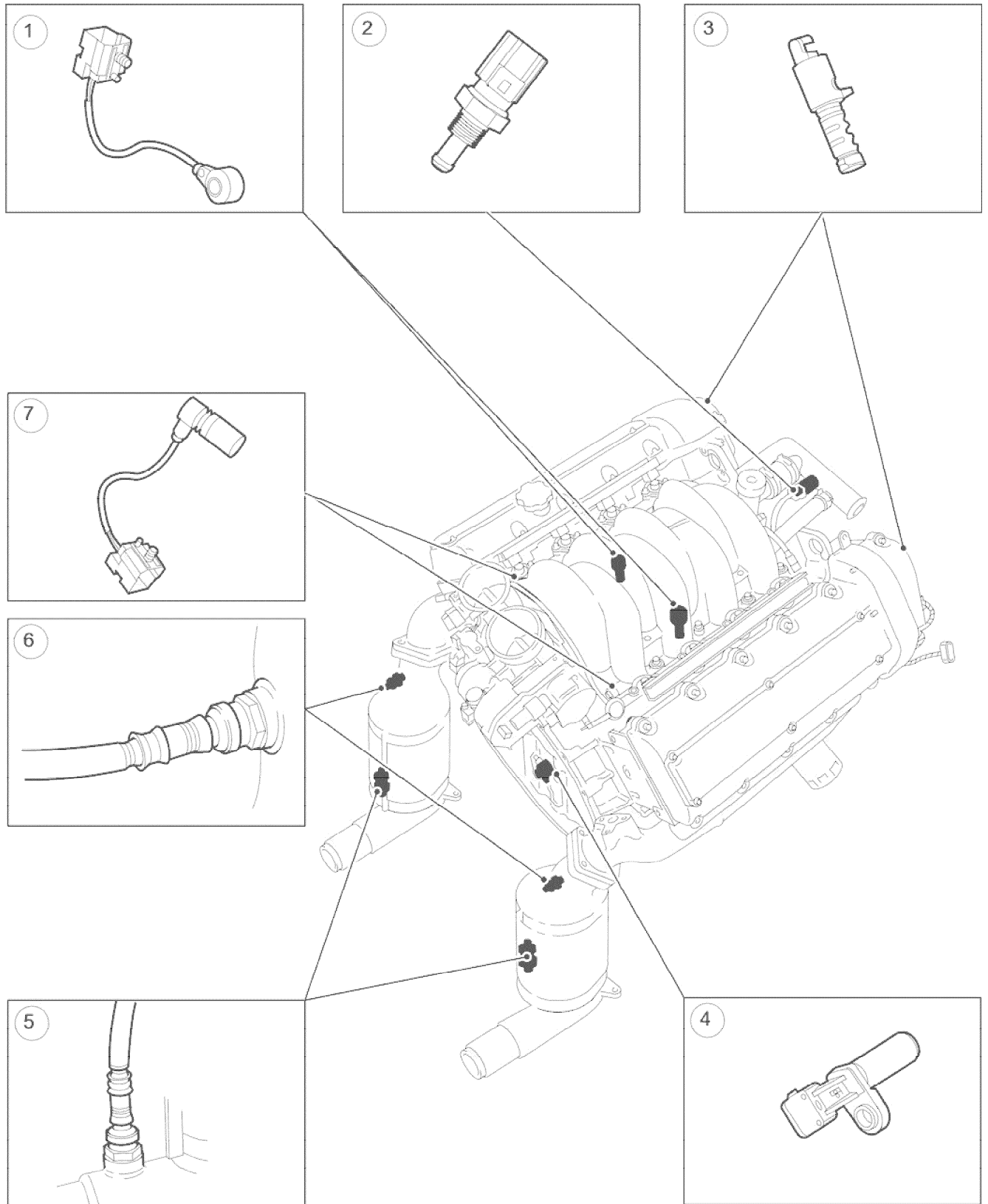

E37606

Parts List

| Item | Description |
|------|-------------|
|------|-------------|

1999 XK RANGE - Electronic Engine Controls - 303-14

| | |
|---|---|
| 1 | Knock sensors (KS) |
| 2 | Engine coolant temperature (ECT) sensor |
| 3 | Variable camshaft timing oil control solenoid |
| 4 | Crankshaft position (CKP) sensor |
| 5 | Catalyst monitor sensor |
| 6 | Heated oxygen (HO2) sensor |
| 7 | Camshaft position (CMP) sensor |

Electronic Engine Control

The engine management system provides optimum control of the engine under all operating conditions using several strategically placed sensors and any necessary actuators. Electronic engine control consists of:

- engine control module
- throttle position sensor
- engine coolant temperature sensor
- camshaft position sensor
- crankshaft position sensor
- mass air flow sensor
- charge air cooler intake air temperature sensor (vehicles with supercharger)
- knock sensor
- heated oxygen sensor
- Catalyst monitor sensor

Engine Control Module (ECM)

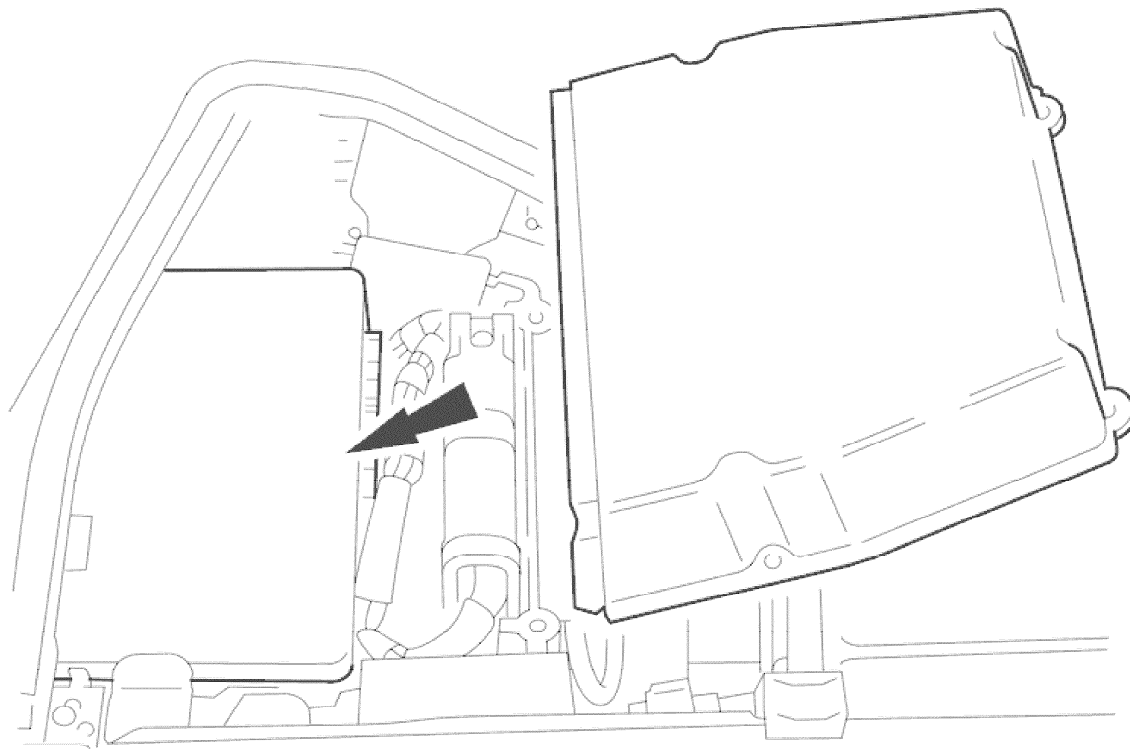

E34101

The ECM incorporates a comprehensive monitoring and diagnostic capability including software variations to ensure system compliance with the latest diagnostic and emissions legislation in different markets. The engine control module controls the coil on plug ignition system, electronic fuel system, cruise control and the electronic throttle control system.

The ECM responds to input signals received from sensors relating to engine operating conditions and provides output signals to the appropriate actuators. These output signals are based on the evaluated input signals which are compared with calibrated data tables or maps held within the ECM before the output signal is generated.

The ECM needs the following inputs to calibrate the engine properly:

- camshaft position
- engine rpm
- engine coolant temperature
- amount of engine detonation

Throttle Position (TP) Sensor

Location

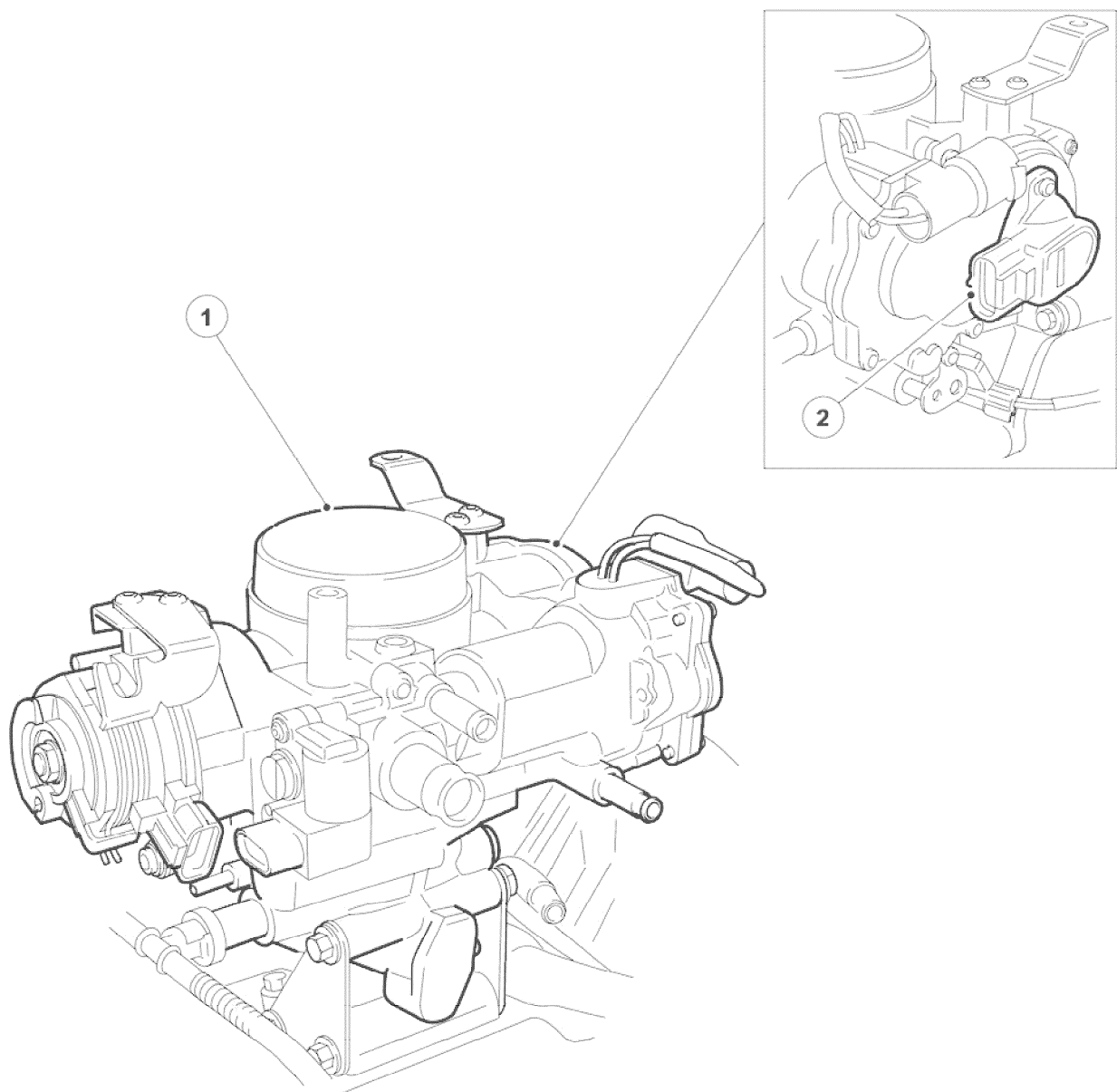

E37607

Parts List

| Item | Description |
|------|-------------------------------|
| 1 | Throttle body |
| 2 | Throttle position (TP) sensor |

- sends the ECM a signal indicating throttle plate angle
- is the main input to the ECM from the driver
- is mounted on the motor end of the throttle body

The throttle body also has an accelerator pedal position (APP) sensor consisting of twin potentiometers which provide separate analogue input signals, proportional to driver demand to the ECM. As a further safety feature the two potentiometers have different input/output characteristics for unique signal identifications and any corrupt signal between the expected outputs will cause the ECM to switch the throttle to limp home mode.

1999 XK RANGE - Electronic Engine Controls - 303-14

Camshaft Position (CMP) Sensor

- sends the ECM a signal indicating camshaft position for fuel synchronization purposes
- is a variable reluctance device mounted on each cylinder head
- generates a signal when the ring fitted to each intake camshaft passes the sensor

Crankshaft Position (CKP) Sensor

- is a variable reluctance device mounted on the engine oil pan
- generates a signal when the drive plate passes the sensor
- sends the ECM signals indicating crankshaft position and engine speed
- is essential for calculating spark timing

Engine Coolant Temperature (ECT) Sensor

- sends the ECM a signal indicating the temperature of the engine coolant
- is a temperature dependent resistor with a negative temperature coefficient (resistance changes inversely with respect to temperature) and is constantly monitored by the ECM

Knock Sensor (KS)

- is a piezo-electric device which sends a signal to the ECM indicating engine detonation

Between 700 and 6800 rpm, the ECM will retard individual cylinder ignition timing when detonation occurs while allowing the other cylinders to continue operating normally.

During acceleration, at critical load and speed conditions, the ECM retards ignition timing to prevent the onset of detonation.

Heated Oxygen Sensor (HO2S)

- are positioned upstream of the catalytic convertor
- is equipped with a heating element which improves the response time of the sensors during engine warm-up
- has the ability to generate a voltage signal proportional to the oxygen content of the exhaust gases leaving the engine
- provides feedback information to the ECM used to calculate fuel delivery and provide optimum gas emissions

Catalyst monitor sensor

- are positioned downstream of the catalytic convertor
- has the ability to generate a voltage signal proportional to the oxygen content of the exhaust gases leaving the catalytic convertor
- provides feedback information to the ECM used to calculate fuel delivery

Variable Camshaft Timing Oil Control Solenoid - Vehicles Without Supercharger.

The variable camshaft timing oil control solenoid is a hydraulic actuator, which advances and retards the inlet camshaft timing, thereby altering the camshaft to crankshaft phasing for optimum engine performance.

Mass Air Flow (MAF) Sensor

Location

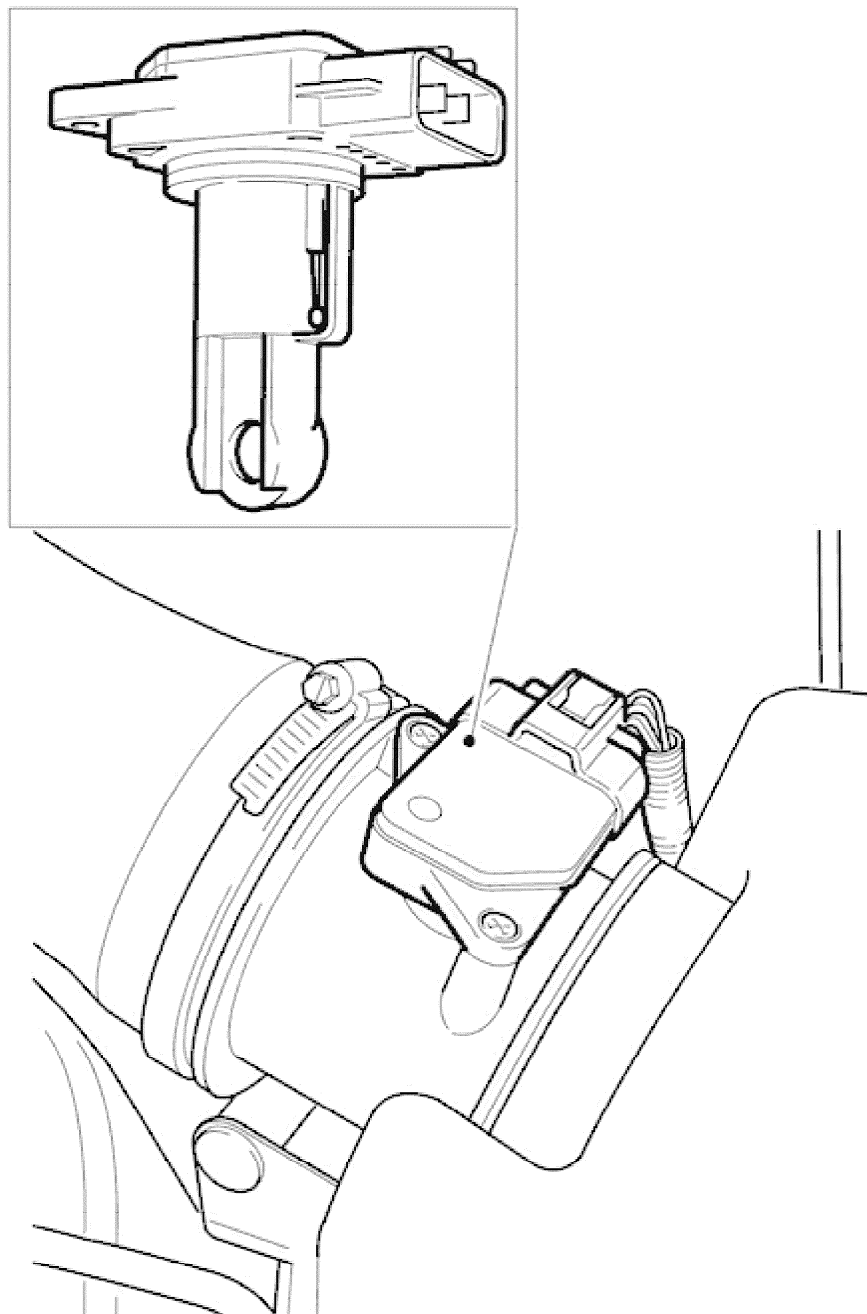

E37608

The MAF sensor informs the ECM of the rate of air flow entering the engine by producing a voltage which is proportional to the rate of air flow into the engine. The voltage produced by the MAF sensor increases as the rate of air flow increases. The ECM takes into account the density of the air entering the air intake system so that it is possible to maintain the required air to fuel ratio, and to compensate for variations in atmospheric pressure.

Integral to the MAF sensor is the intake air temperature sensor (IAT) which measures the temperature of the air

1999 XK RANGE - Electronic Engine Controls - 303-14

entering the air intake system. The ECM uses this information to compensate for higher than normal air intake temperatures.

Intake Air Temperature (IAT) Sensor - Vehicles with supercharger.

Vehicles with supercharger have an additional intake air temperature (IAT) sensor located on the right-hand charge air cooler. The IAT sensor measures the temperature of the air entering the charge air cooler. The ECM uses this information to compensate for higher than normal air intake temperatures.