



Brake System Bleeding Vehicles With: Brembo Brakes

1.  **WARNING:**
IF BRAKE FLUID IS TAKEN INTERNALLY, DRINK WATER AND INDUCE VOMITING. GET MEDICAL ATTENTION IMMEDIATELY.

 **WARNING:**
WASH HANDS AFTER HANDLING BRAKE FLUID. IF BRAKE FLUID COMES INTO CONTACT WITH THE EYES, FLUSH EYES WITH COLD RUNNING WATER. IF IRRITATION PERSISTS SEEK MEDICAL ATTENTION.

 **CAUTION:**
Remove brake fluid spillage immediately from paint work with clean water.

Position vehicle on a four-post lift.

2. Open engine compartment and fit paint work protection covers to fenders.

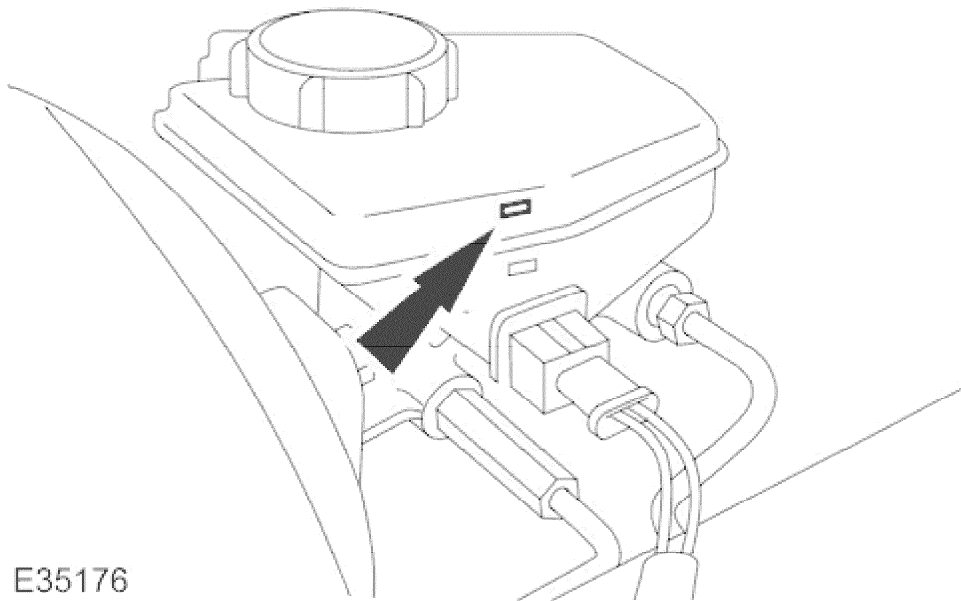

E35176

3. **NOTE:**
Make sure the brake-fluid level does not fall below the fluid reservoir 'MIN' (minimum) mark when bleeding the brake system.

Fill fluid reservoir to the 'MAX' (maximum) mark.

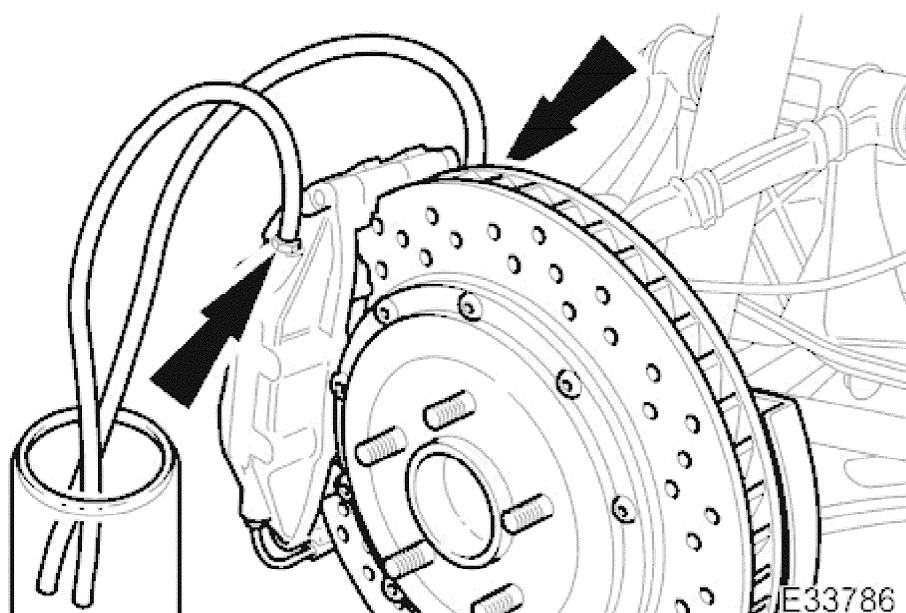

4. Prepare the left-hand front, brake-caliper for bleeding.
- Connect bleed pipes and fluid containers to bleed nipples.

5. Bleed the brake.
1. Apply pressure to brake pedal.
 2. Open caliper's outer bleed nipple.
 3. Fully depress brake pedal.
 4. Close bleed nipple.
 5. Release brake pedal.
 6. Wait two seconds to allow system to prime.
 7. Repeat procedure until air-free brake fluid is expelled from the bleed nipple.
 8. Repeat procedure to caliper's inner bleed nipple.

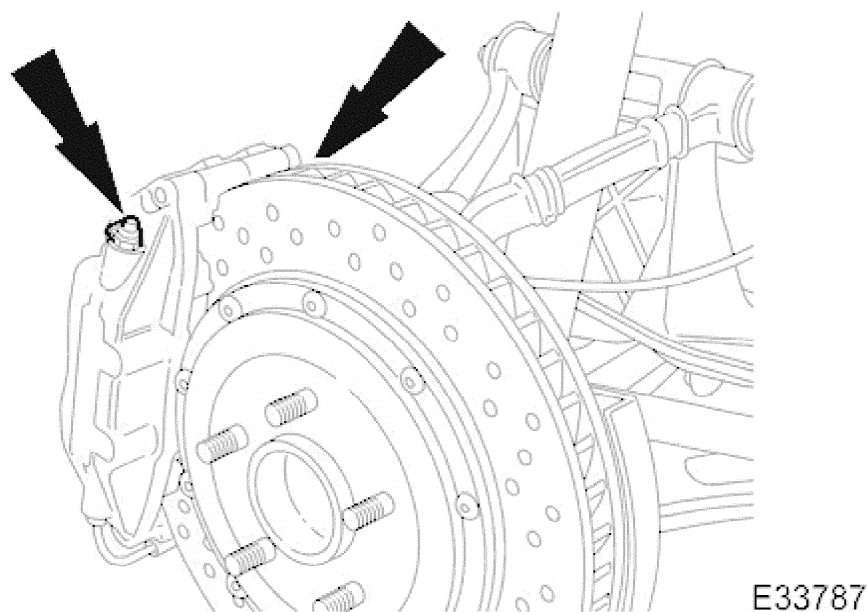

6. Tighten bleed nipples to 12-16 Nm.

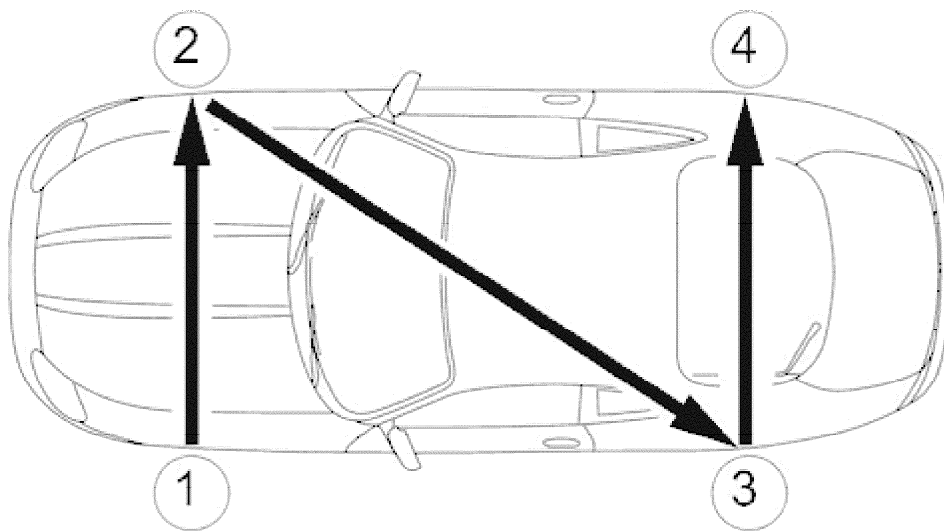

E35183

7. Following the procedure above, bleed the brakes in the order shown:

1. Left-Hand Front,
2. Right-Hand Front,
3. Left- Hand Rear,
4. Right-Hand Rear.

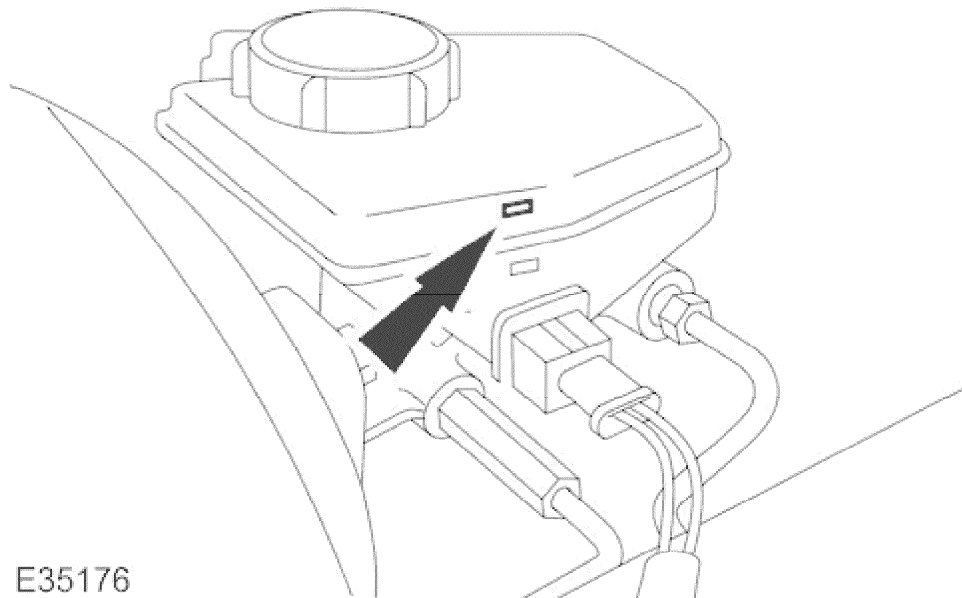

E35176

8.  **CAUTION:**
Remove brake fluid spillage immediately from paint work with clean water.

Fill fluid reservoir.

- Fill reservoir to the 'MAX' mark.
- Fit filler cap.

9. Start engine.

10. Check for correct brake-pedal travel and pressure.

2004 XK RANGE - Brake System - General Information - 206-00

11. Apply brake pedal and check around vehicle for brake fluid leaks.

Make sure brake fluid level is at the 'MAX' mark.