

## Water Pump Vehicles Without: Supercharger 26.50.01

### Removal

1. Open the engine compartment and fit paintwork protection sheets.
2. Drain the cooling system.

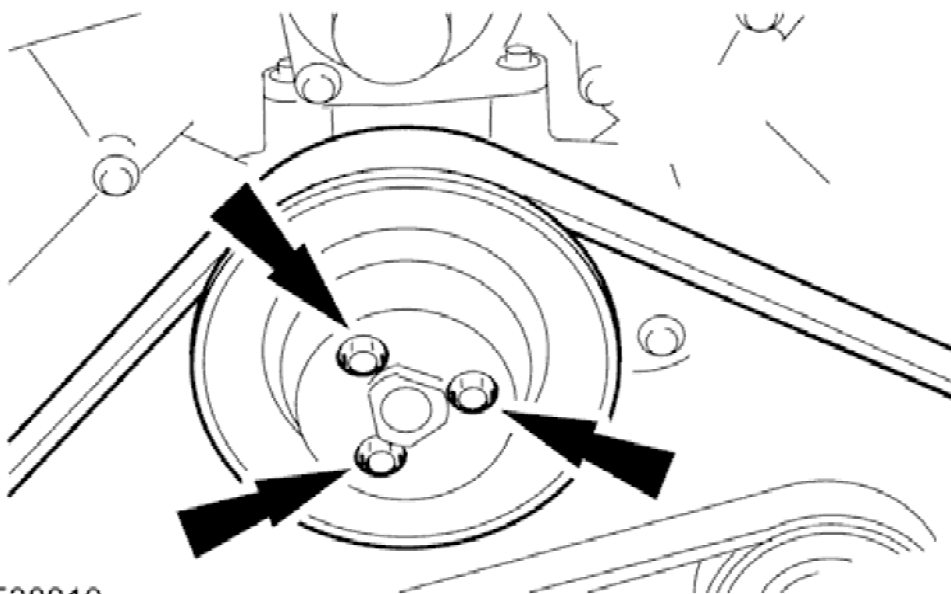

E38810

3. Slacken the three screws which secure the water pump pulley.

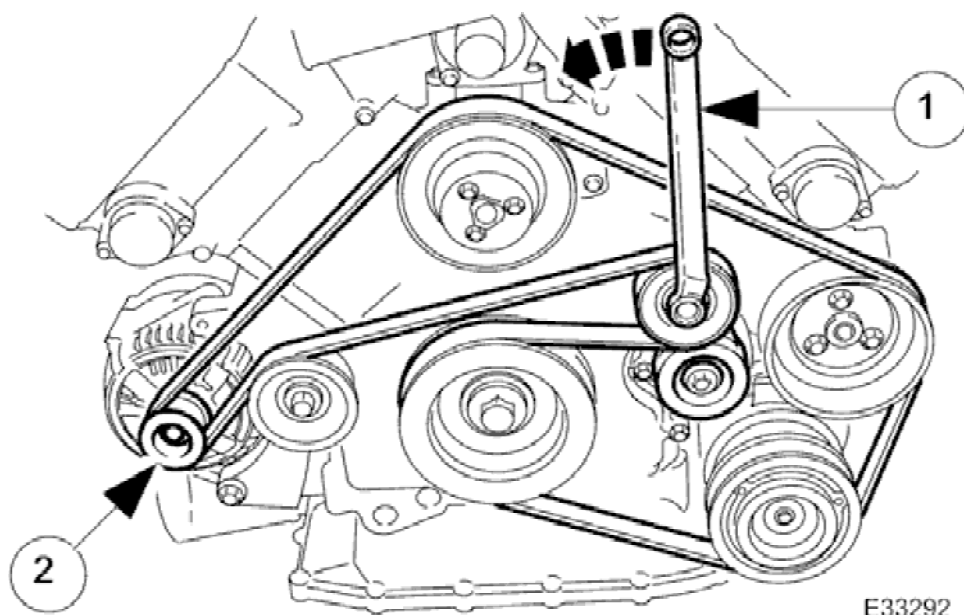

E33292



4. **CAUTION:**

When releasing the belt tension, never apply any torque in a clockwise direction to the pulley centre bolt (left hand thread) as it could subsequently loosen.

Remove the drive belt from the generator and accessory drive.

1. Use a spanner e.g. Churchill JD-230 or Snap On XDHM 1415, on the centre bolt of the belt tensioner idler pulley, to turn the adjuster assembly to the left against spring tension.
  2. Whilst holding the tensioner against spring tension, remove the drive belt from the generator pulley.  
Release the tensioner slowly and remove the spanner.
- Disconnect the belt from the other pulleys, as necessary, to move it clear of the pump pulley.

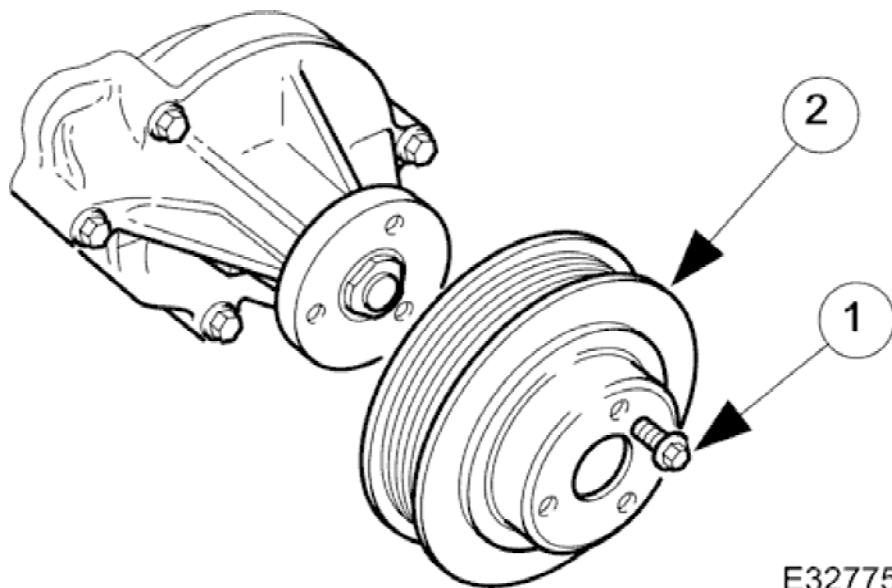

5. Remove the pulley from the water pump.

1. Remove the pulley securing screws.
2. Remove the pulley from the water pump.

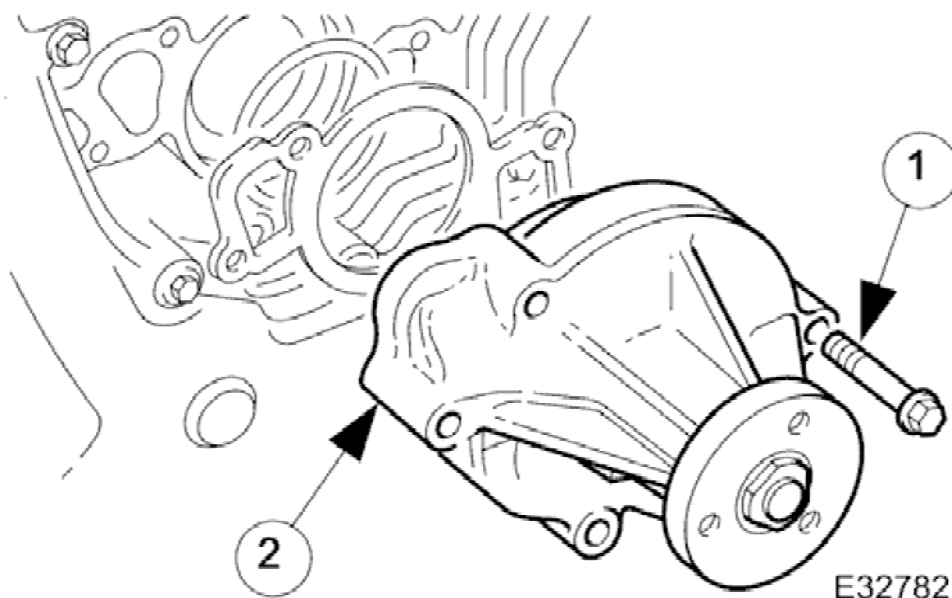

## 2001 XK RANGE - Engine Cooling - 303-03A

6. Remove the water pump.
  1. Remove the five bolts which secure the water pump.
  2. Remove the water pump from the engine.

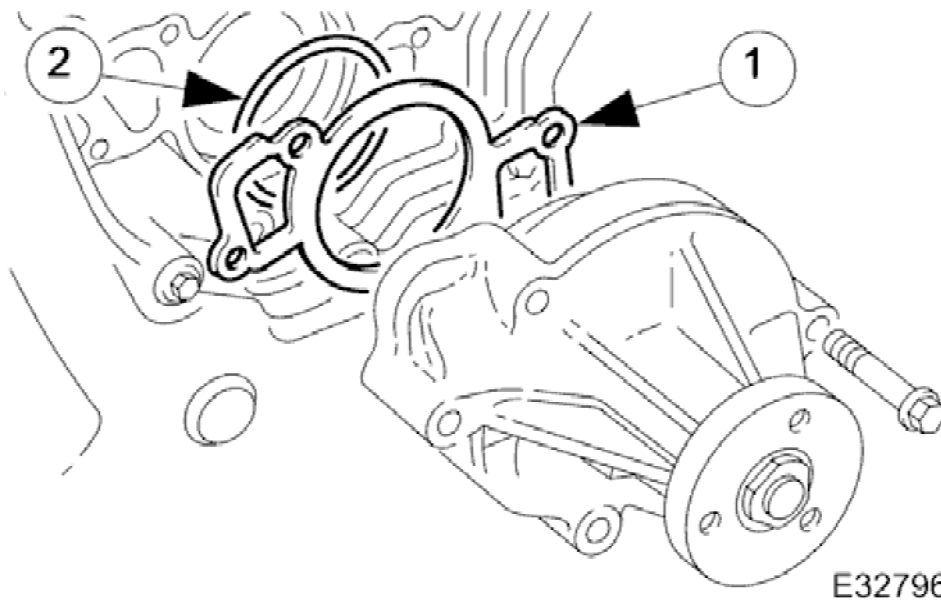

7. Remove the gasket.
  1. Remove and discard the water pump gasket.
  2. Remove and discard the water pump O-ring seal.
8. Clean any coolant spillage from the engine compartment.
9. Clean all relevant parts and sealing faces.

### Installation

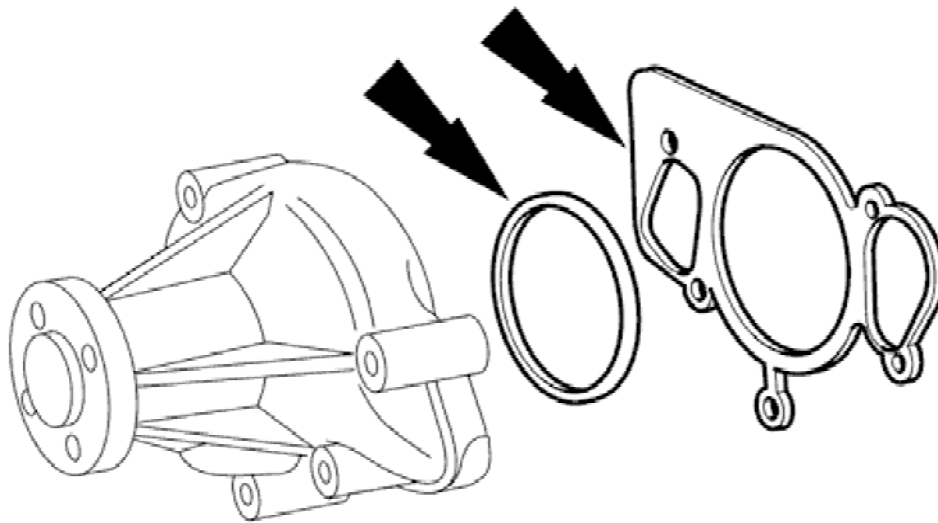

VUJ0001458

1. To install, reverse the removal procedure.
  - Install a new water pump gasket and O-ring seal.

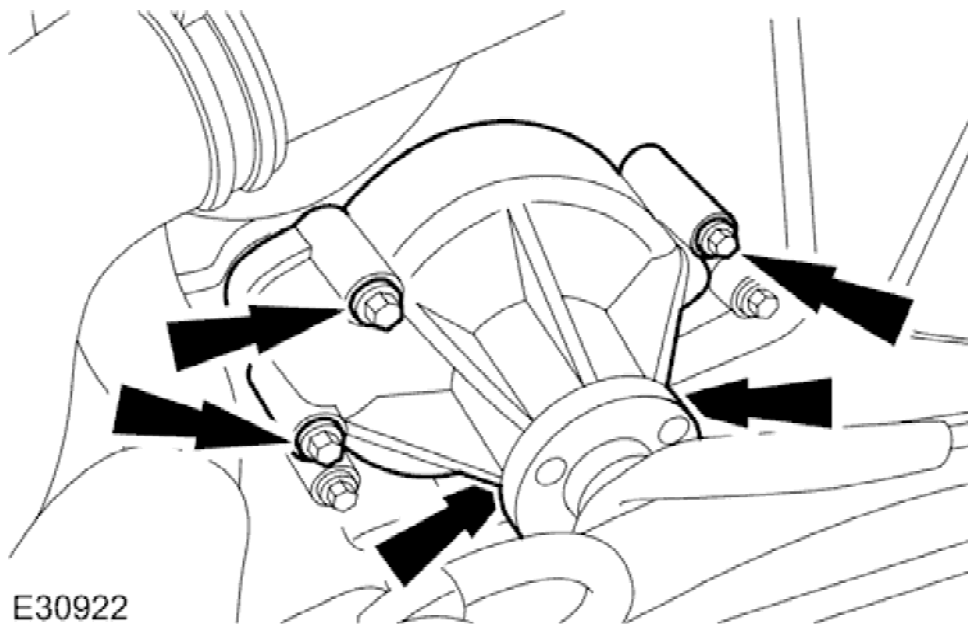

E30922

2. Tighten the water pump bolts to 8 Nm + 90°.

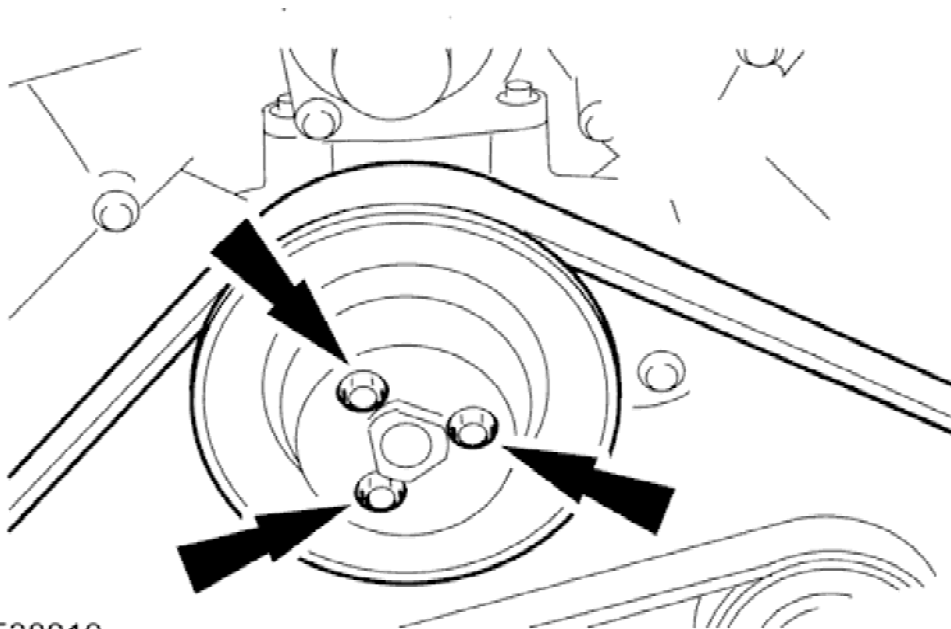

E38810

3. Tighten the water pump pulley bolts to 10-14 Nm.

4. Fill the cooling system.