



BY APPOINTMENT TO
HER MAJESTY QUEEN ELIZABETH II
MANUFACTURERS OF DAIMLER AND JAGUAR CARS
JAGUAR CARS LIMITED COVENTRY



BY APPOINTMENT TO
HER MAJESTY QUEEN ELIZABETH
THE QUEEN MOTHER
MANUFACTURERS OF DAIMLER AND JAGUAR CARS
JAGUAR CARS LIMITED COVENTRY



BY APPOINTMENT TO
HIS ROYAL HIGHNESS THE PRINCE OF WALES
MANUFACTURERS OF DAIMLER AND JAGUAR CARS
JAGUAR CARS LIMITED COVENTRY

Vehicle Care Handbook

JAGUAR CARS LIMITED as manufacturers, are dedicated to the design and production of vehicles which meet the expectations of the world's most discerning purchasers.

To complement the features, systems and technology of your new vehicle we have produced this Vehicle Care Handbook. In it we have undertaken to provide information on vehicle care and maintenance to enable you to obtain lasting pleasure and reliability from your vehicle.

The information contained herein applies to a range of vehicles and not to a specific vehicle. For the specification of a particular vehicle, owners should consult their Jaguar Dealer.

The Manufacturer reserves the right to vary its specifications with or without notice, and at such times and in such manner as it thinks fit. Major as well as minor changes may be involved in accordance with the Manufacturer's policy of constant product improvement.

All rights reserved. No part of this publication may be reproduced, stored in a retrieval system or transmitted, in any form, electronic, mechanical, photocopying, recording or other means without prior written permission from the Service Division of Jaguar Cars Limited.

Contents

1. Introduction

General Information	1-1
The Jaguar Diagnostic System	1-1
Safety Precautions	1-3
Safety, Warning and Caution Labels.	1-5
General Precautions	1-6
Used Engine Oil.	1-7
Hydraulic Fluids	1-7
Hood Release Control	1-8

2. Cleaning

Introduction	2-1
Exterior Care	2-1
Interior Care	2-4

3. Routine checks

Introduction	3-1
Regular Checks	3-1
Tyre Pressure Check	3-2
Reservoir and Dipstick Locations.	3-3
Checking and Replenishment	3-4
Check/Top Up Engine Oil Level	3-4
Checking Coolant Level	3-4
Check/Top Up Windscreen Washer/ Powerwash Reservoir	3-5
Check/Top Up Brake Fluid Reservoir	3-6
Check/Top Up Power Steering Fluid Reservoir.	3-6
Cooling System	3-7
Engine Anti-freeze	3-7
Engine Block Heater	3-7
Recommended Engine Oil	3-8
Capacities	3-9

4. Roadside emergency service

Introduction	4-1
Temporary-use Spare Wheel (where fitted)	4-1
Spare Wheel and Jacking Equipment.	4-1
Spare Wheel Stowage	4-2
Wheel Changing and Jacking	4-2
Fitting the Spare Wheel.	4-7
Emergency Starting	4-8
Vehicle Recovery	4-10
Fuses and Fuse Boxes	4-13
Fuse Box Locations	4-14
Fuse Ratings and Circuits	4-17
Control Modules – Identification and Location	4-22
Relay Identification and Location	4-23
Fire Extinguisher.	4-26

5. Vehicle maintenance

Introduction	5-1
Regular Servicing	5-1
Tyres.	5-1
Care of Wheels	5-4
Battery	5-6
Bulb Renewal	5-9
Bulb Chart	5-16
Windscreen Wiper Blades.	5-17
Windscreen Washers	5-18

6. Specifications

Vehicle Data	6-1
Weights (Approximate)	6-2
Dimensions (Coupe and Convertible)	6-4
Wheel/Tyre Data.	6-5
Fuel Requirements	6-8

7. Accessories

Electrical Accessories	7-1
Electrical Accessory Supply Sockets	7-1
Earth Points	7-1

A comprehensive index is located at the back of this book.

General Information

When left-hand or right-hand is used in the text, this refers to the left-hand side or right-hand side of the vehicle, viewed from the rear.

Jaguar Dealers

Jaguar Dealers are chosen with care. Each is dedicated to providing a Sales, Service and Genuine Jaguar Parts facility of the highest standard.

Jaguar Dealers provide full technical back-up from the factory with comprehensive training for all their technicians. All Dealers' workshops operate to the highest standard and have all the necessary approved tools and equipment essential to maintain or repair Jaguar vehicles.

The Jaguar Diagnostic System

The equipment used to assist diagnosis of faults in the electrical and electronic systems of the vehicle is unique and is only available to Jaguar Dealers. Use of this equipment will enable the Dealer to trace and rectify faults in the system and ensure that only faulty components are repaired or replaced.

Caution: Severe damage to the electrical system and electronic components can occur if any attempt is made to diagnose faults in the electrical system using conventional diagnostic equipment (i.e. use of test lamps, low impedance voltmeters, etc.).

Regular Servicing

Each vehicle is given a full 'Pre-Delivery Inspection' to ensure that all systems function correctly and the vehicle meets its specification.

Regular maintenance and servicing is the responsibility of the owner. Jaguar Dealers will be pleased to arrange periodic servicing in accordance with the USA/Mexico 'Passport to Service' Booklet or Canadian 'Club Jaguar' Warranty and Benefits Information Booklet.

USA and Mexico: Jaguar Dealers will arrange appointments on a mileage or time interval basis to ensure that all routine and corrective maintenance work is undertaken and recorded in the 'Passport to Service' Booklet.

Canada: Jaguar Dealers will arrange appointments on a distance or time interval basis to ensure that all routine and corrective maintenance work is undertaken and recorded in the 'Club Jaguar' Warranty and Benefits Booklet.

Failure to implement maintenance at the recommended intervals could result in deterioration of vehicle performance and possible infringement of regulations.

1-2 Introduction

Maintenance Summary

It is the owner's responsibility to ensure that the vehicle is maintained in accordance with the Maintenance Schedules. Repairs resulting from a failure to maintain are not covered by the warranty.

The USA/Mexico '**Passport to Service**' Booklet or Canadian '**Club Jaguar**' Warranty and Benefits information Booklet is a convenient document to record all maintenance services on the vehicle.

All vehicle literature should be passed to any subsequent owner at the time of resale.

USA and Mexico: If the '**Passport to Service**' Booklet is not available, a replacement may be obtained by writing to the Consumer Relations Department, Jaguar Cars, 555 MacArthur Boulevard, Mahwah, New Jersey 07430, quoting the vehicle identification number from the plate located inside the windscreen, plus the date of purchase and current mileage or kilometres.

Canada: If the '**Club Jaguar**' Warranty and Benefits Information Booklet is not available, a replacement may be obtained by writing to the consumer Relations Department, Jaguar Canada, 8 Indel Lane, Bramalea, Ontario, L6T 4H3, quoting the vehicle identification number from the plate located inside the windscreen, plus the date of purchase and current kilometres.

Scheduled Maintenance

The Maintenance Schedules list all the maintenance operations and their intervals. Because of the need for the use of specialized equipment and skills, it is strongly recommended that all service work be entrusted to a Jaguar Dealer.

Should the vehicle cover a low annual mileage, have a high proportion of short journeys or operate in severe conditions, Jaguar Cars recommend that the lubrication service shown in the maintenance schedule in the '**Passport to Service**' Booklet be performed at intervals not to exceed six months.

The Maintenance Schedules may be revised from time to time. Jaguar Dealers will be notified of revisions by Service Policy Letters or Technical Bulletins.

USA only: Maintenance, replacement or repair of the emission control devices and system may be performed by any automotive repair establishment or individual using any automotive part which has been certified by Jaguar Cars.

Safety Precautions

Take particular note of **WARNINGS** and **Cautions** given throughout this handbook.



WARNING:

Warnings are procedures which must be followed precisely to help avoid the risk of personal injury.

Caution: Cautions are procedures which must be followed precisely to reduce the possibility of damage to the vehicle and resultant risk of personal injury or inconvenience.

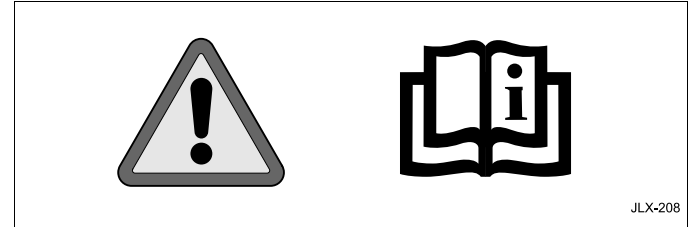

Warning symbols on the vehicle

On encountering the warning triangle and open book symbol on the vehicle, it is important that you consult the relevant section of this handbook before touching this part of the vehicle or attempting adjustments of any kind.

1-4 Introduction

Safety Precautions (continued)



WARNING:

1. Many liquids and other substances used in vehicles are poisonous and must never be consumed and should be kept away from open wounds. These substances include antifreeze, brake fluid, fuel, windscreen washer additives, lubricants and various adhesives.
2. The presence of any unusual fumes (e.g. gasoline or exhaust fumes) in the passenger compartment and/or luggage compartment should be corrected immediately by a Jaguar Dealer. If you must drive under these conditions do so only with all windows fully open.
3. Any modifications to the fuel system not specifically designed for this Jaguar are prohibited. Such modifications in some circumstances could result in a fire. All service actions must be entrusted to a Jaguar Dealer.
4. Alterations to the electrical system, including the fitting of accessories not designed for this Jaguar will cause damage to the electrical circuits and systems. In some circumstances this could result in a fire. All accessory work should be entrusted to a Jaguar Dealer.
5. No attempt should be made to repair a fuse that has blown. Always install a fuse of the correct amperage (see fuse charts, pages 4-16 to 4-20). Failure to comply with the above may cause a fire hazard or serious damage elsewhere in the electrical circuit
6. Avoid contact with battery acid which is poisonous and corrosive. Acid will cause burns to the skin as well as to the eyes. In the event of skin or eye contamination, wash the affected area with water thoroughly. Seek immediate medical attention when eye contact has occurred.
7. Never reverse the battery terminal connections. Always disconnect both terminals before battery charging.
8. When disconnecting the battery connections, always disconnect the earth terminal first and reconnect last.
9. Batteries produce combustible gas (hydrogen) when charging. Switch off the charger before connecting or disconnecting terminal connections to avoid sparks and short circuits.
10. Do not disconnect any pipes in the air conditioning refrigeration system. A refrigerant is used which can cause blindness if allowed to contact the eyes. FIRST AID: If refrigerant should contact the eyes or skin, wash the eyes or affected area with cold water for several minutes. Do not rub. As soon as possible thereafter, obtain treatment from a doctor or eye specialist.

California Proposition 65 Warning



WARNING:

Engine exhaust, some of its constituents, and certain vehicle components contain or emit chemicals known to the State of California to cause cancer and birth defects or other reproductive harm.

Safety, Warning and Caution Labels

Note: Do not remove any warning labels from the under hood area or inside of the vehicle.

Braking System (A)

The brake fluid caution symbol is moulded into the master cylinder filler cap.

Brake system warning information is moulded into the master cylinder reservoir and states:

WARNING: CLEAN FILLER CAP BEFORE REMOVING. USE ONLY SUPER DOT 4 BRAKE FLUID FROM A SEALED CONTAINER.

Cooling System (B)

The header tank label is located on the filler cap and states:
WARNING – DO NOT OPEN WHEN HOT.

Power Steering System (C)

The label is located on the reservoir filler cap and states:
WARNING.

Refer to SECTION for topping up the power steering system.

Rotating Components (D)

A label is located on the fan shroud and states:
WARNING – ROTATING COMPONENTS – KEEP CLEAR.

Climate Control System (E)

The label located under the head on the left-hand side states:
CAUTION – System pressurised with HFC refrigerant 134a. System to be serviced by qualified personnel.

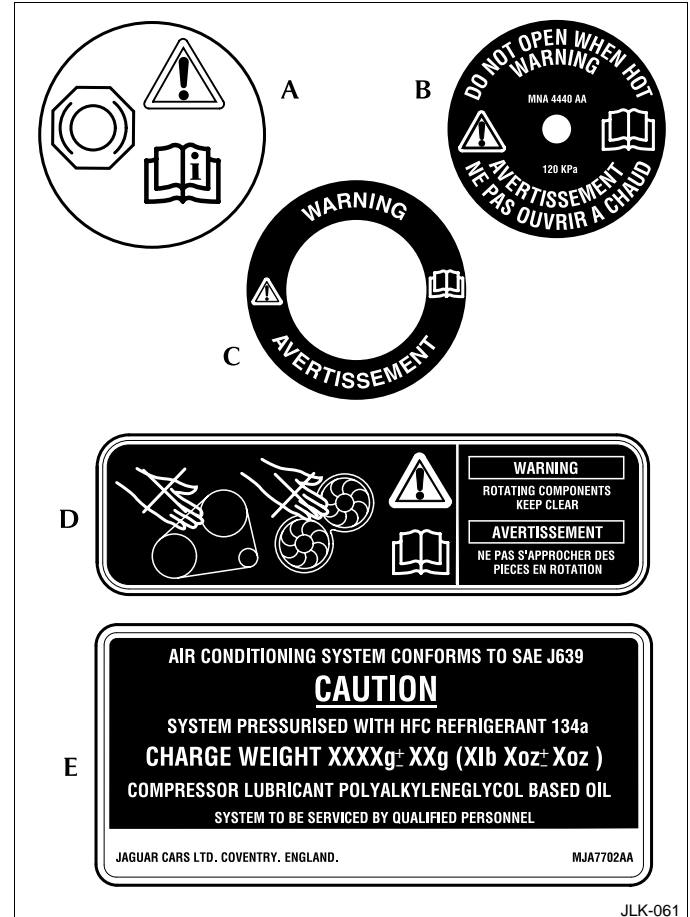

1-6 Introduction

General Precautions

- Ensure that the vehicle is securely supported before working underneath it. **Chock the front wheel and apply the handbrake.**
- Whenever possible use a suitable wheel-free lift when working beneath the vehicle. If a jack is used to support the vehicle, use axle stands carefully placed at the jacking points to provide a rigid support. **Do not** use any jacking equipment under the front cross member
- Ensure that adequate ventilation is provided when volatile degreasing agents are being used.
- **Never** use volatile cleaning fluids under a vehicle standing over a pit. Many such fluids give off vapours which are heavier than air and dangerous to inhale.
- Wear protective overalls, ensure loose clothing (ties, etc.) are removed or covered when working adjacent to moving components (fan belts, etc.).
- Do not leave opened containers of oil, fuel, etc., about the work area. Always refit caps/seals to partially used containers when storing them for later use.
- Do not leave tools, equipment, spilt oil, etc., around or on the work area.

- Place a fire extinguisher close to the vehicle and disconnect the negative battery terminal. Do not use a naked flame to provide illumination, especially under the vehicle, or in the engine and luggage compartments. Do not smoke while working on the vehicle.
- Do not apply heat in an attempt to free nuts or fittings. This will damage protective coatings and there is a risk of damage to electronic equipment and brake and fuel lines from conducted heat.
- Inspect power leads of any mains electrical equipment for damage, and check that it is properly earthed.

General Precautions Against Damage

- When working in the engine compartment protect the exterior paintwork by using suitable covers over the wings and scuttle.
- To prevent soiling the interior, carry out jobs requiring access to the passenger or luggage compartments first. If a job involves access to the interior in the course of other work, prevent the transfer of oil and grease to the interior by using seat and carpet covers and wearing clean overalls and gloves.
- Always use a recommended service tool, where specified.
- Avoid spilling hydraulic fluid or battery acid on paintwork. Wash off with water immediately if this occurs.

General Precautions (Continued)

Used Engine Oil



WARNING:

Prolonged and repeated contact may cause serious skin disorders, including dermatitis and cancer.

Always use a hand cream to protect the skin from oil contamination. Avoid contact with the skin as far as possible and wash thoroughly after any contact. Keep oils out of reach of children.

PROTECT THE ENVIRONMENT: It is illegal to pollute drains, water courses and soil. Use authorised waste collection facilities, including civic amenity sites and garages providing facilities for the disposal of used oil, oil filters and batteries. If in doubt, contact your Local Authority for advice on disposal.

Engine and Throttle Settings

Do not attempt to make adjustments to the engine or throttle settings. Many vehicle systems are controlled by complex electronic devices and require specialist knowledge. Such work should be entrusted to a Jaguar Dealer.

Battery/Ignition Isolator Switches

Non-approved battery isolator switches, which disconnect the power supply to all electrical circuits, are **not** recommended.

Hydraulic Fluids

The Brake Hydraulic Fluid in the master cylinder and brake operating system uses non-mineral polyglycol based brake fluid with a minimum standard of JAGUAR SUPER DOT 4. **ONLY FLUID OF THIS TYPE AND STANDARD MAY BE USED.**



WARNING:

Contamination of the brake system fluid by as little as 1% will cause rapid deterioration of the system seals. Ensure that the brake fluid reservoir cap is securely fitted.

Electrical Accessories

The fitting of any electrical accessory **should only** be entrusted to a Jaguar Dealer. Refer to **Electrical Accessories** in Section 7. This information must be observed before fitting any accessories.

1-8 Introduction

Hood Release Control

The hood lock release control is below the fascia on the driver's side.

To open: Release the hood lock by pulling the lever. Reach across to the centre of the hood and lift the rear edge. The gas filled struts will assist raising the hood, and retain it in the fully open position.



WARNING:

Before closing the hood ensure that no one is obstructing the closing area and that hands and clothes are clear. Remove tools, cleaning cloths, etc. from the engine compartment.

Hood latching: Close the hood to within a distance of 10 to 12 inches (250 to 300 mm) of the fully closed position. Place the left hand on the hood as shown at (A). Then pressing downwards slam the hood shut. This action should engage both the right-hand and left-hand latches.

Should one latch fail to engage, place both hands as shown at (B) above the unlatched side and press down firmly on the hood until it engages.

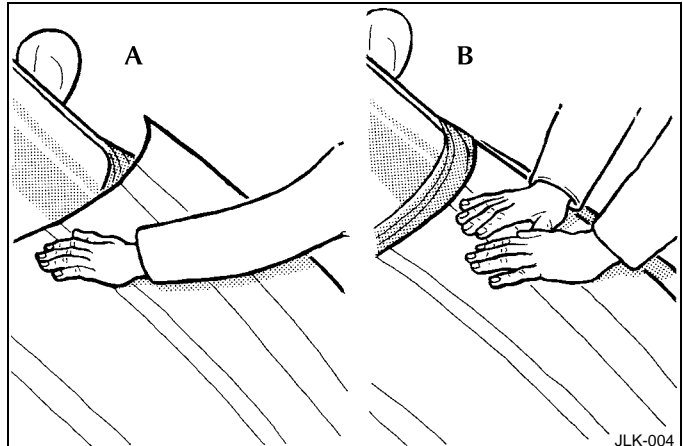
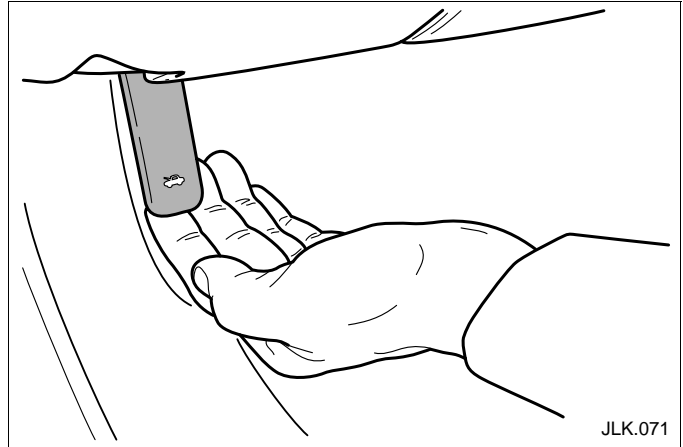

Introduction

This section gives full details of the methods and cleaning agents which should be used to achieve the best results and maintain the finish of the vehicle, both internally and externally.

Read carefully the restrictions on the use of jet washes and automatic car washes. Note that convertible models should not be washed in an automatic car wash that has rotating brushes.

Exterior Care

Valet Kit

A selection of Car Care products is available from the Jaguar accessory range.

Note: All the cleaning materials mentioned in this section are available from the Jaguar Accessory Range.

Washing

For best results, do not wash the vehicle under strong sunlight. Always allow the vehicle to cool down before washing.

Do not use a dry cloth to wipe dirty paintwork. Dust and grit are abrasive and will cause scratches. Remove dirt using a cellulose sponge and plenty of warm (never hot) water. Rinse with clean water and dry with a clean, damp chamois leather.

Do not use household soaps or detergents. The use of Jaguar Vehicle Shampoo is recommended.

Do not direct hoses at full force around door and luggage compartment seals and the convertible top. Using high pressure water jets on the paintwork is not recommended.

Do not allow bird droppings or tree sap to harden. Remove from paintwork immediately with a lukewarm soap and water solution.

In winter, when salt is used on the roads, wash the vehicle frequently, and immediately after encountering such conditions. Clean undersides and wheel arches using a high pressure jet.

Automatic Car Wash

Caution: Convertible models: Do not use an automatic car wash that has rotating brushes. The action of the brushes may damage the exterior fabric of the convertible top.

Note: Regular use of automatic car washes tends to dull the lustre of the paintwork.

Before entering the car wash it is essential to:

Switch off the radio to retract the aerial,
Remove wing mounted telephone antennas,
Fold down screen mounted telephone antennas,
Fold in door mounted rear view mirrors.

Note: If your vehicle is fitted with a Jaguar approved cellular telephone, you are advised to switch the telephone and the ignition OFF.

After leaving the car wash, switch on the windscreen wipers immediately to remove water and prevent a build up of wax. Jaguar Screen Clean Paste helps prevent this.

Removing Grease and Tar

Remove grease or tar with methylated spirit (alcohol). White spirit is also effective, but must not be applied to rubber, particularly the windscreen wiper blades.

2-2 Cleaning

Glass Surfaces

To avoid scratching glass surfaces, **do not** clean dirty glass with **dry** paper or cloth. Use clean, warm water and a chamois leather which is reserved for glass only.

The following products will ensure glass surfaces and windscreen wiper blades are kept in good condition:

Jaguar Screen Clean Paste – Apply to the exterior of the windscreen **only** to ensure effective operation of the windscreen wiper blades.

Jaguar Glass Cleaner – Interior and exterior of all other surfaces.

Jaguar Screen Wash – Washer reservoir additive.

Jaguar De-icer, ice scraper, anti-mist wipe cloth – for use in adverse weather conditions.

Note:

1. Renew the wiper blades when worn to prevent scratching. Clean regularly with a mild detergent solution.
2. The windscreen should be cleaned with Jaguar Screen Clean Paste at every service interval.

Under Hood Cleaning

Under hood cleaning using high pressure hoses or steam cleaners should only be carried out by a Jaguar Dealer. The electronic control modules and fuse boxes could be damaged by indiscriminate use of cleaning equipment.

Convertible Top Fabric

Caution:

1. **Automatic car wash brushes and detergents may damage the fabric.**
2. **Do not use spot cleaners, chemical dilutants or any organic cleaners. If in doubt, contact your Jaguar dealer.**

To maintain the appearance and condition of the convertible top, the recommendations given below should be followed. This is of particular importance in the case of light coloured tops.

Do not leave the top in the open (folded) position for longer than is necessary, as in certain circumstances permanent soiling along the folds may occur.

Cleaning: Every 1000 miles (1600 km) vacuum clean and wash the convertible top using the Jaguar Soft Top Cleaning Kit, carefully following the instructions enclosed.

Reproofing: Every 5000 miles (8000 km) reproof the top using the solution in the cleaning kit, carefully following the instructions enclosed.

Paint Chips

Scratches and chips should be touched in before weathering action begins. Inspect the paintwork immediately after the vehicle has been washed.

Polishing Paintwork and Chromium Plating

For maximum protection against road dust, salts, industrial fallout etc., it is recommended that the vehicle is polished regularly using Jaguar Polish, Chrome Polish and a Polishing Cloth.

Alloy Road Wheels

Alloy wheels have an anti-corrosion protective coating, which should not be damaged.

Wash the wheels at two week intervals to avoid an accumulation of particles which could become embedded in the wheel surface.

In salty conditions the wheels should be cleaned weekly.

Chromium-plated Alloy Road Wheels

It is recommended that chromium-plated alloy road wheels are cleaned using Jaguar Vehicle Shampoo and Chrome Polish.

Caution: Do NOT use proprietary wheel cleaners.

Aerial Care

Regular cleaning with a special aerial cleaner, will ensure smooth and reliable operation of the aerial.

Always wipe the aerial in an upwards direction.

Lubricate using an aerial maintenance wipe cloth.

In freezing conditions check that no ice has formed over the top of the aerial, which could prevent it being raised and cause damage to the motor.

The Jaguar Aerial Cleaning Kit contains the necessary maintenance items.

2-4 Cleaning

Interior Care

Brush and clean the interior regularly. Use a vacuum cleaner where possible to remove all dust from the interior and trim.

Carpets

Marks or stains can be removed by gentle scrubbing with a weak solution of soap and warm water.

For more stubborn stains a commercially available carpet cleaner should be used. See your Jaguar Dealer for advice.

Headlining

Remove dust in the headlining with a vacuum cleaner. To remove stains, rub briskly without pressing, using a lint-free white cloth, moistened with methylated spirit.

Leather Upholstery

Dust and dirt can penetrate the pores and creases of leather, causing surface wear and brittleness. To prevent ingrained dirt, inspect the seat upholstery regularly and clean every one to two months as follows:

- Wipe the seat surfaces with a clean, damp, non-coloured cloth, changing frequently to a clean area of cloth. Avoid over-wetting.
- If this is not sufficient, use a cloth which has been dampened with warm soapy water and then wrung out; avoid over-wetting. Use only mild non-caustic soap.
- Use Jaguar Leather Cleaner for heavily soiled areas.
- Dry off and rub with a clean soft cloth, changing surfaces regularly.

When staining (eg from clothing) or spillages occur, clean the affected area immediately as described above.

Every two to three months, clean as above and then apply a minimum amount of Jaguar Hide Food to maintain the leather in first class condition.

Note: Do not use solvents such as petrol (gasoline), white spirit or alcohol. Do not use detergents, furniture polish or household cleaners. Although such treatments may give, initially, an impressive appearance, their use will lead to rapid damage or deterioration of the leather, and will not be covered by the Manufacturer's Warranty. Unless spillages such as tea, coffee or ink are washed away immediately, permanent staining may have to be accepted.

If a valeting service is used, ensure that the specialist firm concerned are aware of, and follow these instructions precisely.

Introduction

The few maintenance tasks and checks required to ensure reliable and safe day to day running of the vehicle are detailed in this section.

Only use lubricants and fluids which meet the specifications recommended by Jaguar Cars Limited.

Regular Checks

In the interests of safety and reliability, it is advisable to carry out the following checks at the recommended intervals, and always before starting on a long journey.

Daily

Check that there is sufficient fuel for the journey intended, particularly at night and before entering motorways.

Check that there is adequate windscreen washer fluid for the intended journey.

Weekly

Tyres – Check the tyres, including the spare, for condition and pressure. See Section 6 for the recommended tyre pressures.

Lights – Check that all exterior lights and direction indicators function correctly and that the lenses are clean.

Engine Oil – With the vehicle standing on level ground, check the oil level and top up if necessary with oil of the correct grade, see page 3-3, 3-4 and 3-8.

Engine Coolant – With the engine **cold**, check the level of the coolant in the engine header tank, see page 3-3, 3-4 and 3-7. Any loss of fluid must be checked by a Jaguar Dealer.

Brake Fluid – Check the level of the fluid in the brake fluid reservoir, see page 3-3 and 3-6. Top up if necessary with new, unused Jaguar approved brake fluid.

The brake fluid reservoir is initially nearly full, but the level will drop as the brake pads wear. If the level appears unusually low, location of the fluid leakage **must** be checked by a Jaguar Dealer.

Power Steering Fluid – With the engine cold check the level of the fluid in the power steering fluid reservoir, see page 3-3 and 3-6. Top up if necessary with fluid of the correct specification. Any loss of fluid should be checked by a Jaguar Dealer.

Note: The transmission and, where fitted, the supercharger are sealed for life units and do not require topping up.

Monthly

Windscreen Washer – Top up with recommended windscreen washer fluid and clean soft water, see page 3-3 and 3-5. Check the operation of the washer. Use Jaguar Windscreen Washer Fluid additive to prevent freezing.

Wiper Blades – Check the quality of the wipe. If smearing or juddering is evident, clean the windscreen as detailed in Section 5 and renew the wiper blades.

3-2 Routine checks

Tyre Pressure Check

Certain alloy wheels have a slotted screw valve cover on the wheel face. To access the valve, adopt the following procedure.

Locate Pouch

A pouch containing a 'T'-shaped screwdriver and a valve adaptor, is stowed in the glovebox.

Fit Adaptor

On the wheel face, locate the slotted screw valve cover.

Loosen and remove it with the screwdriver (1).

Fit and hand tighten the adaptor (2) to the valve.

Position tyre pressure gauge on the adaptor and take the reading.

Note: Recommended tyre pressures are given on page 6-7.

Remove Adaptor and Stow Pouch

On completion of the tyre pressure check, loosen and remove the adaptor, refit the slotted screw valve cover and tighten with the screwdriver.

Return the adaptor and screwdriver to the pouch and stow in the glovebox.

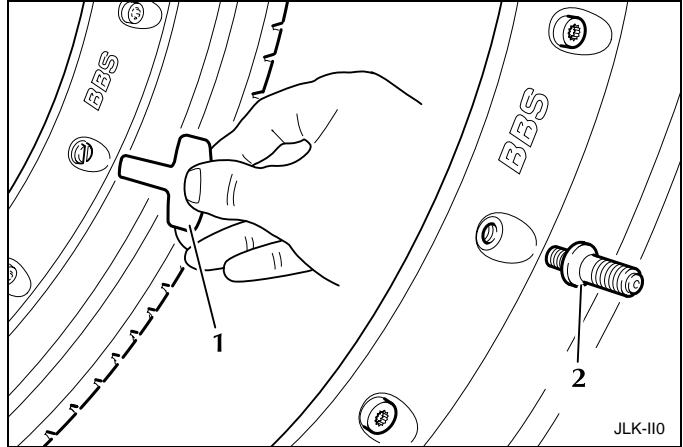

Reservoir and Dipstick Locations

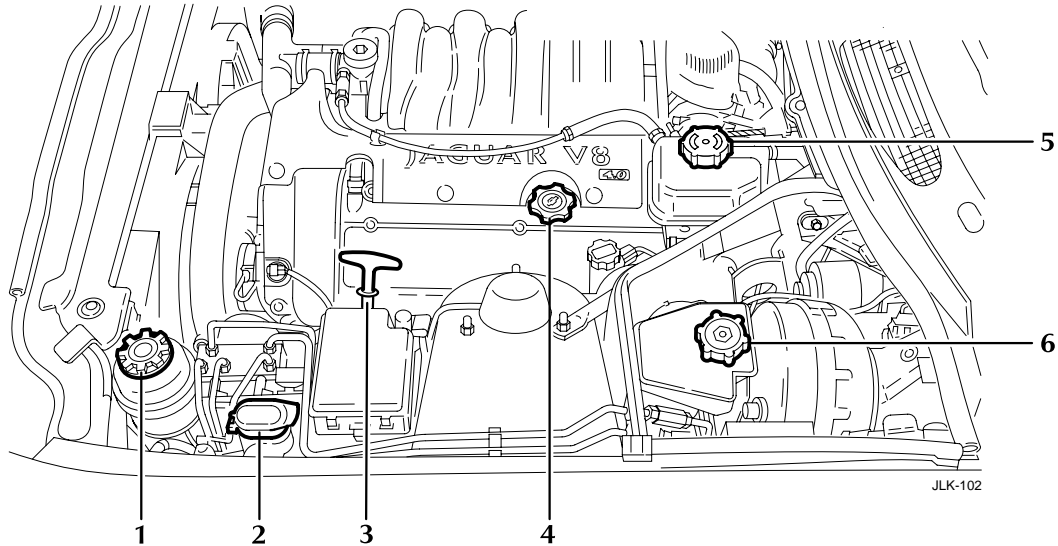

- | | |
|--------------------------------|--------------------------------|
| 1. Power steering reservoir | 4. Engine oil filter |
| 2. Windscreen washer reservoir | 5. Coolant filter pressure cap |
| 3. Engine oil dipstick | 6. Brake fluid reservoir |

3-4 Routine checks

Checking and Replenishment

Check/Top Up Engine Oil Level

Check the oil level regularly with the vehicle on flat, level ground.

Refer to page 3-3 for dipstick and oil filler locations.

It is preferable to check the oil level after the vehicle has been standing, that is, with the engine completely cold.

If the engine has been started do not check the oil level until the engine has reached normal operating temperature.

Stop the engine and wait for a minimum of two minutes to allow the oil to drain back into the sump.

Remove the dipstick and wipe clean with a non-fluffy cloth. Replace fully, then withdraw the dipstick.

The oil level is correct when it is at the top of the crosshatched section.

The difference in oil quantity between the lower edge of the crosshatched section (MIN) and the top of the crosshatched section is 1 quart (1 litre).

The oil must not be allowed to exceed the MAX level.

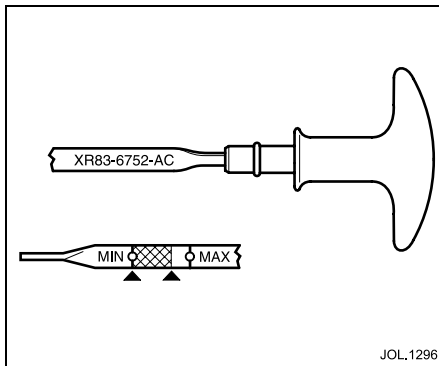

To top up, remove the oil filler cap and add oil to the correct specification as detailed on page 3-8.

Caution: Do not use oil additives of any type. Use only specified lubricants.

Refit the filler cap and hand tighten securely.

The supercharger (where fitted) is oil filled-for-life and does not require any checks to be made by the driver.

Checking Coolant Level

The coolant level must only be checked when the engine is COLD.

See page 3-3 for coolant header tank location and page 3-7 for the coolant specification.



WARNING:

Do not remove the coolant expansion tank filler/pressure cap while the engine is hot. If the cap must be removed, protect the hands against escaping steam and slowly turn the cap anticlockwise until the steam pressure starts to escape. Leave the cap in this position until all the pressure has escaped, and then remove the cap completely.

The coolant level should be up to the bottom of the filler neck of the header tank. If persistent coolant loss is noticed have a Jaguar Dealer investigate the cause immediately.

Refit the filler cap and hand tighten securely.

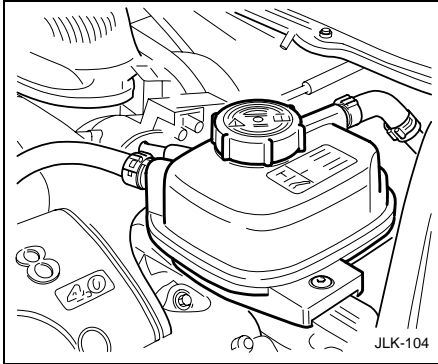

Topping up

Caution: Antifreeze will damage paintwork. Avoid spillage.

With the engine cold, top up the header tank until the coolant is level with the bottom of the filler neck.

Use the correct concentration of Jaguar Antifreeze/Coolant/ Corrosion Inhibitor as detailed on page 3-7.

Check/Top Up Windscreen Washer/ Powerwash Reservoir

See page 3-3 for windscreen washer reservoir location.

The washer reservoir contains the fluid for the windscreen washers and the headlamp powerwash system (where fitted).

Fill to just below the neck with Jaguar Windscreen Washer Fluid diluted with clean, preferably soft water as specified in the maker's instructions on the bottle.

Do not over-fill.

Note: Using a non-approved fluid may adversely affect the rubber of the windscreen wiper blades, resulting in ineffectual and noisy wiping.

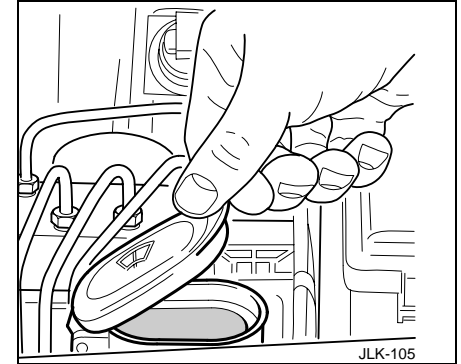

Cold Weather Precautions

To prevent damage to the pump under freezing conditions, use recommended Jaguar Windscreen Washer Fluid.

Caution:

1. **Windscreen washer fluid is toxic and in concentrated form is flammable.**
2. **Under no circumstances must cooling system antifreeze be used, since this will damage the paintwork.**

After adding screen washer fluid to the reservoir, operate the pump until untreated water is purged from the pipes and jets.

3-6 Routine checks

Check/Top Up Brake Fluid Reservoir



WARNING:

The brake fluid level will drop as the brake pads wear. If the level is very low report the loss of fluid to the nearest Jaguar Dealer. Do not drive the vehicle until the cause is rectified.

Caution:

1. While handling brake fluid, take extreme care; brake fluid must not contact the vehicle paintwork.
2. Always use fresh, clean fluid from a new container. Never introduce used brake fluid into the system.

See page 3-3 for brake fluid reservoir location.

The fluid is visible through the translucent casing of the reservoir and must be maintained at the 'MAX' mark.

If necessary, top up as follows:

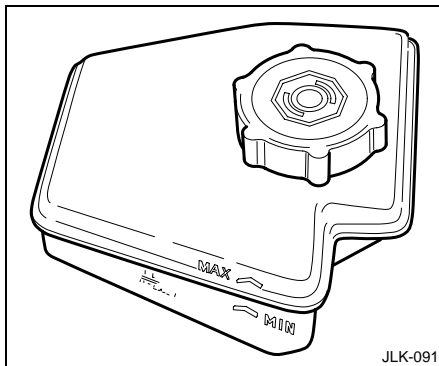

Before removing the cap, clean the reservoir and cap thoroughly with a lint free cloth to ensure that no foreign matter enters the reservoir.

Unscrew the filler cap and top up to the 'MAX' level using new Jaguar brake fluid, specification JAGUAR ITT SUPER DOT 4. This is a non-mineral polyglycol based brake fluid.

Refit the filler cap securely.

Should any brake fluid be spilt, replace the cap on the reservoir before rinsing it away, to avoid contamination.

Check/Top Up Power Steering Fluid Reservoir

Caution: It is imperative that the power steering system does not become contaminated in any way. Always dispense fluid from a fresh sealed container and clean the area around the reservoir neck both before and after topping up. Never return drained fluid to the system.

See page 3-3 for power steering fluid reservoir location.

Check the fluid level when the engine is 'COLD' and the vehicle is on a flat, level surface.

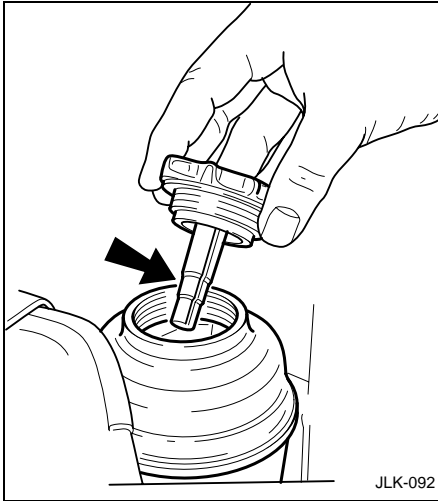

Wipe clean and remove the filler cap from the reservoir; take great care to prevent any foreign matter from entering. Check that the fluid level is between the marks on the dipstick.

If necessary, top up with DEXRON III fluid, **DO NOT OVERFILL.**

Should the level be very low, report the loss of fluid to the nearest Jaguar Dealer.

Cooling System

The cooling system should be filled or topped up with a mixture of 50% plain water and 50% Jaguar Antifreeze, Coolant and Corrosion Inhibitor conforming to specification:

WSS M97B44-D,

coloured orange, Extended Life Coolant.

This antifreeze mixture gives frost protection for temperatures down to -40°F (-40°C).

Caution: Do not mix with anti-freeze of a different specification as this would damage the cooling system.

Engine Antifreeze

Antifreeze, when used at the correct concentration, not only protects the engine from frost damage in winter, it also provides all year round protection against internal corrosion.

Use only antifreeze to specification, WSS M97B44-D, coloured orange, Extended Life Coolant. Inferior quality antifreeze may be ineffective in maintaining adequate frost and corrosion protection to the cooling system.

The coolant solution may remain in the cooling system for five years or, 150 000 miles (240 000 kilometres) after which the cooling system should be drained, flushed and refilled.



WARNING:

Do not allow antifreeze to make contact with skin or eyes. If this should happen, rinse the affected area immediately with plenty of water.

Engine Block Heater

If the vehicle is to be started at temperatures of -22°F (-30°C) and lower, it is recommended that an engine block heater is fitted and used. Failure to do so may result in damage to the drive belt.

For further information consult your Jaguar Dealer.

Caution: The fitting of an engine block heater does not eliminate (lessen) the need for antifreeze under freezing conditions.

3-8 Routine checks

Recommended Engine Oil

Oil Specification

API SJ / EC and ILSAC GF-2.

When topping up between oil changes, make sure that you use oil that has the correct quality level (API service) and viscosity grade. Your vehicle's warranty may be invalidated if damage is caused by use of improper engine oil.

When the oil level is at the lower dipstick mark, add one quart (one litre) of engine oil.

SAE Viscosity Rating

It is recommended that you use only approved engine oils to meet the SAE Viscosity Range / Ambient Temperature Scale shown below. For maximum fuel economy, 5W/30 oil is recommended.

Caution: Do not use oil additives of any type. Use only specified lubricants.

Recommended SAE Viscosity Range / Ambient Temperature Scale

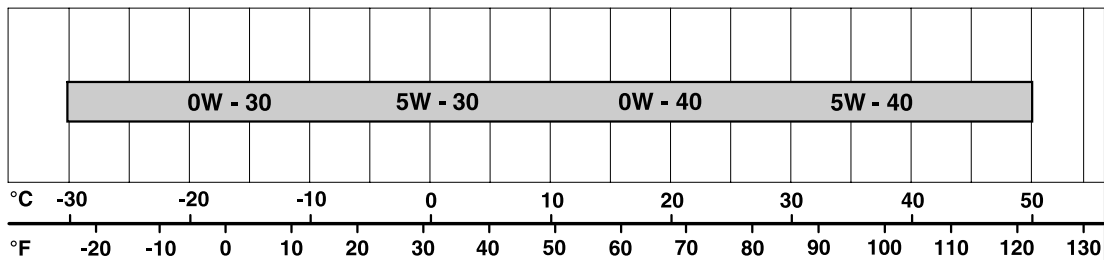

JOL.654

Capacities

	US Quarts	Litres
Engine oil: service oil change with new oil filter		
– with or without oil cooler	7.4	7
<p>The rear axle (final drive unit), automatic transmission unit and supercharger (where fitted) are oil filled-for-life and will not normally require to be topped up.</p>		
<p>Cooling system, including reservoir and climate control:</p>		
– Initial fill – 4.0 litre normally aspirated	10.0	9,5
– Initial fill – 4.0 litre supercharged	12.2	11,5
Windscreen Washer Reservoir	7.4	7,0

Capacities - Fuel Tank

	US Gallons	Litres
Indicated refill capacity (E to F on fuel gauge)	18.5	70,0
Unindicated capacity (Below E on fuel gauge)	1.3	5,0
Total refill capacity	19.8	75,0

3-10 Routine checks

Introduction

In the event of a flat tyre, drivers should follow closely the procedure for wheel changing and jacking given in this section. The correct jacking points and how to locate them are shown. It is important that only the correct jacking points are used.

Where vehicles have the 'Temporary Use' spare wheel, drivers should be aware of the limitations of its use.

Temporary Use Spare Wheel (where fitted)

Observe the following warnings before using the wheel.



WARNING:

1. **Please note temporary use spare wheel warning label. Adhere to instructions on the label. Failure to comply can be dangerous.**
2. **When a temporary use spare wheel is fitted, drive with caution and replace with the specified wheel and tyre as soon as possible.**
3. **Do not fit more than one temporary use spare wheel and tyre assembly at one time.**
4. **The temporary use spare wheel must be inflated to 60 lbf/in² (4.2 kg/cm², 410 kPa, 4,1 bar).**
5. **Temporary use spare wheel, maximum speed is 50 mph (80 km/h).**

Note: Maintenance information for the temporary use spare wheel is the same as given for normal tyres in Section 5.

Spare Wheel and Jacking Equipment

The spare wheel, jacking equipment and wheel chock are stored under the luggage compartment floor panel.

To remove the spare wheel, remove the luggage compartment floor panel and unscrew the retaining screw (see **A overleaf**).

The tray containing the jacking equipment kit can be removed from the luggage compartment by unscrewing the yellow securing bolt (see **B overleaf**).

The kit comprises: the jack; jack ratchet handle with socket extension; wheel nut wrench with telescopic extension; wheel chock; towing eye and a wheel locking nut extractor tube and key socket (where fitted).

Note: Examine the jack occasionally, clean and grease the threads to ensure it is always ready for an emergency.

4-2 Roadside emergency service

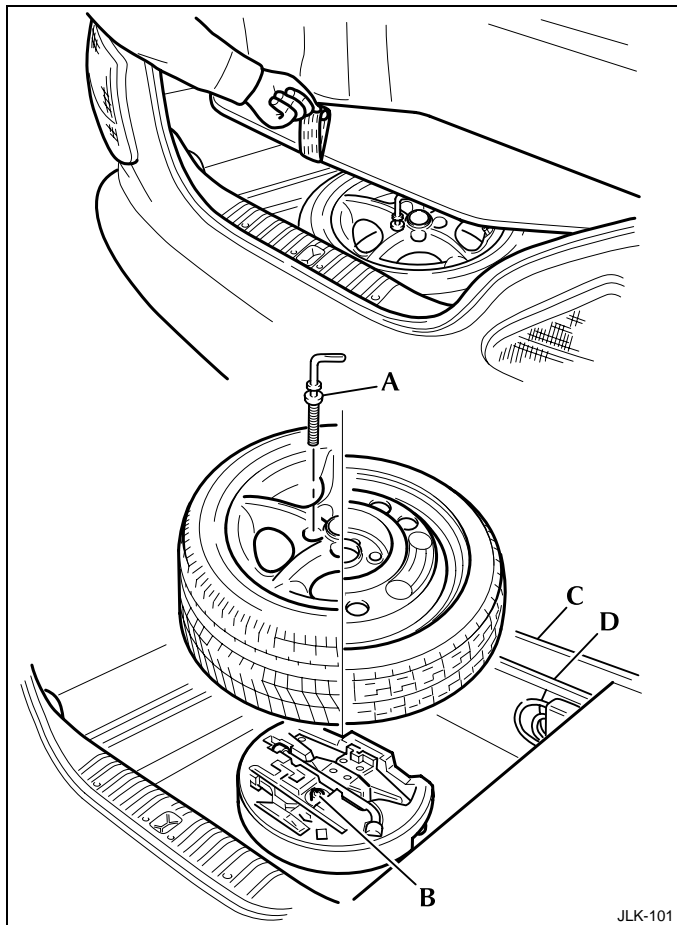

Spare Wheel Stowage

When the temporary use spare wheel is being used, stow the replaced road wheel in the luggage compartment so that it fits over the jacking equipment tray. Reposition the luggage compartment floor panel in the upper location slots (C).

When the temporary use spare wheel is returned to the luggage compartment, position the wheel with one stud hole directly over the yellow plastic bolt. Fit the retaining screw through the stud hole into the bolt head and tighten down. Refit the luggage compartment floor panel in the lower position (D).

Note: Remove the centre badge, see illustration on page 4-3. 20 inch diameter road wheels cannot be stored beneath the luggage compartment floor panel. Use the plastic stowage bag and gloves provided in the luggage compartment.



WARNING:

Keep plastic bags away from children.

Wheel Changing and Jacking

Be prepared for a flat tyre. Know where equipment is stowed and read the wheel changing and jacking instructions carefully.

Stopping the vehicle

Pull off the road completely, clear of all traffic and park on a level ground as possible. Switch on hazard warning lights.



WARNING:

It can be dangerous to change a wheel when the vehicle is on a slope or soft, uneven ground.

Wheel Changing and Jacking (continued)

Remove the temporary use or full size spare wheel to obtain the jack and wheel changing tools.

Alloy wheels with centre badge

When changing wheels, carefully remove the centre badge and transfer it to the replacement wheel (when a full size spare wheel is used).

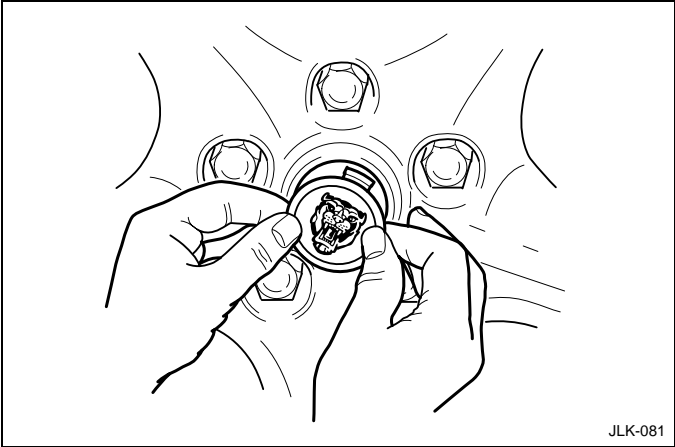

Alloy Wheels with Hexagon Centre Wheel Nut Covers

Remove the cover with the plastic spanner supplied with the spare wheel jacking equipment.

Loosening the wheel nuts

Always slightly loosen the wheel nuts before raising the vehicle. A label showing correct use of the wheel nut wrench is printed on its shaft and states:

WHEEL NUT REMOVAL

WHEEL NUT TIGHTEN



JLK 053

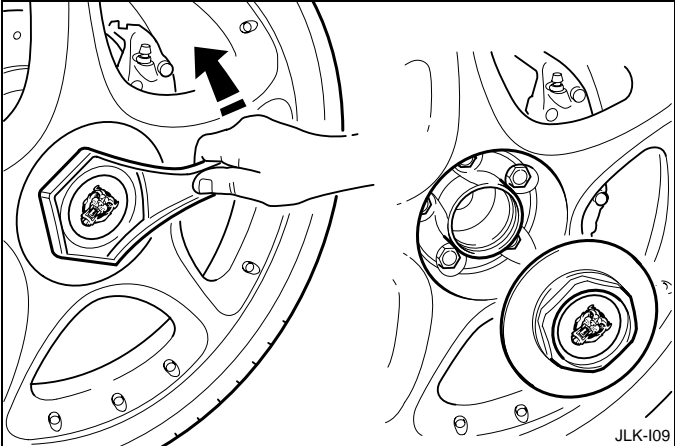

4-4 Roadside emergency service

Wheel Changing and Jacking (continued)

Removing locking wheel nuts (where fitted)

Some vehicles are fitted with one locking wheel nut on each wheel. These can only be removed using the extractor tube and key socket from the jacking equipment tray.

The locking wheel nut is provided with a cover which makes it visually similar to standard wheel nuts. The top of the cover has an indentation (A) to aid identification.

Push the extractor tube firmly over the locking wheel nut cover, as shown at (B), until it is fully located.

Withdraw the extractor tube to remove the cover.

Fit the key socket over the locking wheel nut as shown at (C).

Fit the wheel nut wrench over the key socket and loosen the locking wheel nut.

Locking wheel nut security coding

Locking wheel nuts have a letter stamped on their upper surface. The key socket is stamped with a corresponding number. Only key sockets with the correct matching number will fit the locking wheel nut.

Should a new key socket be required, note the letter on the locking wheel nut and contact your Jaguar Dealer. Proof of vehicle ownership will be required.

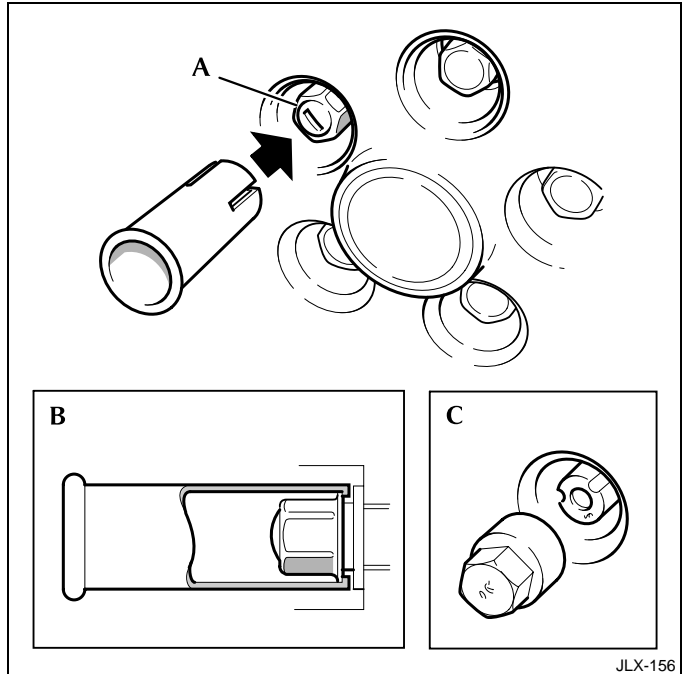

Wheel Changing and Jacking (continued)

Before lifting the vehicle



WARNING:

Before attempting to lift the vehicle with the jack, chock one of the front wheels to prevent the vehicle from rolling when jacked up.

A folding wheel chock is supplied with the jacking equipment. The chock must be unfolded into a triangular form before use.

Chock the front wheel on the opposite side of the vehicle to the side being jacked up as shown below.:

Note:

1. Ensure that all passengers are in a safe place clear of the vehicle.
2. Ensure that the jack is on firm and level ground.
3. Firmly apply the handbrake and select position 'P' (Park).

Using the wheel nut wrench with the handle extended, slacken, but do not remove the wheel nuts

VEHICLE FACING DOWN A SLOPE

Chock the front of the front wheel

VEHICLE FACING UP A SLOPE

Chock the rear of the front wheel

VEHICLE HORIZONTAL

Front wheel change: Chock at **A**

Rear wheel change: Chock at **B**

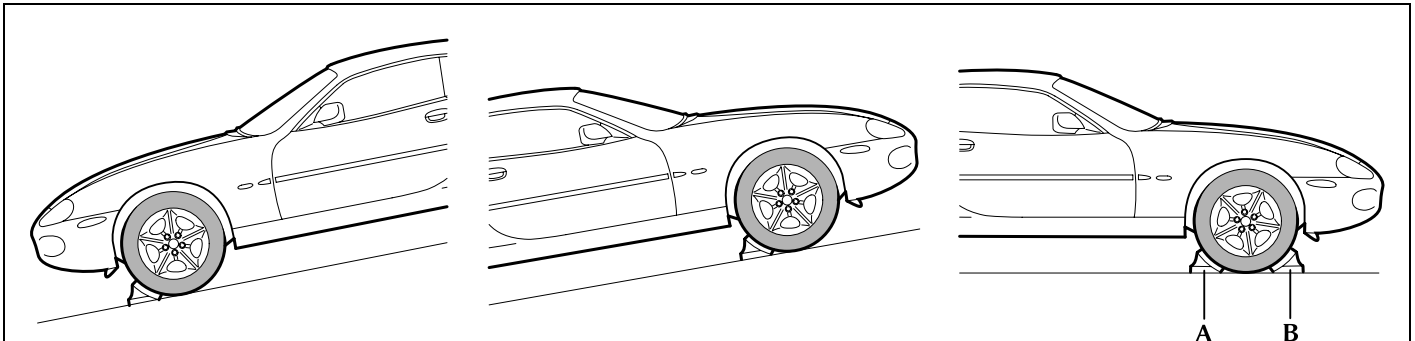

4-6 Roadside emergency service

Wheel Changing and Jacking (continued)

Jacking

 **WARNING:**

Never work under the vehicle using only the jack as a support, always use axle stands or suitable supports under the jacking points.

Observe the instructions printed on the jack.

Use the jack only for lifting the vehicle during wheel changing, and only use the jack which is stored in the vehicle.

Do not start or run the engine while the vehicle is only supported by a jack.

Note: When one rear wheel is lifted off the ground the automatic transmission 'P' (Park) position will not prevent the vehicle from moving and possibly slipping off the jack.

There are four jacking points, two each side. These are reinforced metal plates (A) attached to the sill near each wheel.

Caution: Never use bumpers or any other part of the body to lift the vehicle.

 **WARNING:**

Do not attempt to lift the vehicle unless the sill plate is fully engaged in the jack plate groove.

Place the jack squarely beneath the appropriate jacking point. Fit the extension socket to the jack ratchet head and fit it to the jack. Ensure that the jack plate groove is fully engaged with the sill plate.

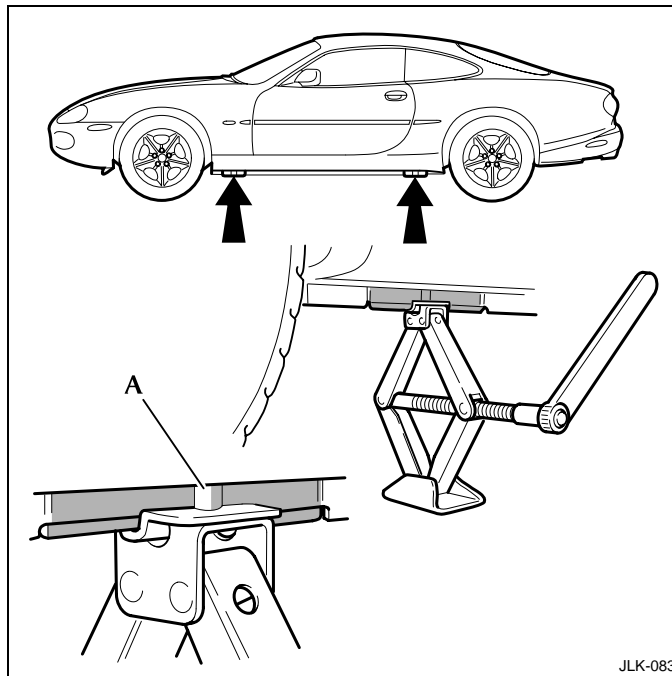

JLK-083

Carefully raise the vehicle by turning the ratchet handle.

Note: Stop jacking the vehicle when the tyre just clears the ground. Minimum tyre lift gives maximum vehicle stability. Remove the wheel nuts and the wheel.

Wheel Changing and Jacking (continued)

Fitting the Spare Wheel



WARNING:

When using the wheel nut wrench, only use the extension for removing wheel nuts, NOT for tightening.

Fit the spare wheel and secure with the wheel nuts.

Using the wheel nut wrench, lightly tighten the wheel nuts alternately using the sequence shown. Ensure that the taper on the wheel nuts is seated fully onto the taper faces of the wheel disc.

Lower the jack and with the wrench handle not extended, tighten the wheel nuts alternately. At the earliest opportunity have the wheel nuts tightened with a torque wrench to 65 – 75 lbf.ft (88 – 102 Nm). Do not exceed this torque.

Remove the jack from the vehicle.



WARNING:

When the temporary use spare wheel has been fitted, drive with caution and replace with the specified wheel and tyre as soon as possible.

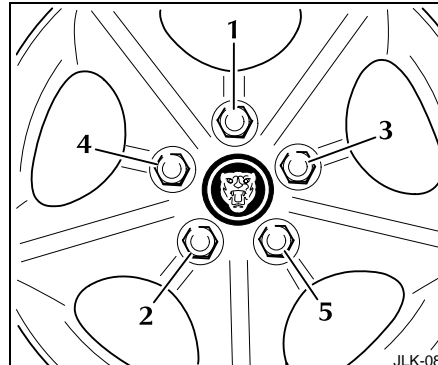

Re-fitting centre badge

Press fit the centre badge into position on the wheel.

Refitting Hexagon Centre Wheel Nut Cover (where fitted)

Tighten the hexagon centre wheel nut cover to the wheel with the plastic spanner supplied with the spare wheel jacking equipment.

Stowing the equipment

Remove the chock and fold flat.

Stow the jack, wheel chock and tools in the jacking equipment tray. If removed, refit the tray in the luggage compartment and secure with the yellow securing bolt.

Place the wheel over the tray and refit the luggage compartment floor panel.

Note: When the temporary spare wheel is returned to the luggage compartment, fit and tighten the retaining screw.

4-8 Roadside emergency service

Emergency Starting

Rolling Start

A start by pushing or towing cannot be achieved on a vehicle with automatic transmission.

Emergency Starting Using Jump Leads

Both the booster and discharged battery should be treated with great care when using jump leads. Always use high quality leads capable of carrying the starter current of the vehicle to be started.

Before commencing, the following precautions must be taken:

1. When the battery of another vehicle is being used, ensure that the vehicles do not touch, or remove the charged battery and place near to, not on, the vehicle with the discharged battery.
2. Ensure that both vehicles have all electrical services OFF, the handbrake is ON and the transmission is in Park.
3. Where the jump leads are of a different colour, e.g. red and black, use red for positive (+). This aids identification and helps to avoid crossing positive (+) to negative (-). Take extra care to avoid crossing the polarity when using cables of the same colour.

Caution:

1. **If using a jump start vehicle, under no circumstances should the vehicles come into contact with each other. This could establish an earth connection, which may cause sparks and damage.**
2. **Do not run the jump start vehicle's engine when boost starting a Jaguar Vehicle. If the jump start vehicle's engine is running and the jump leads are disconnected, damage to the Jaguar vehicle's electrical system will result.**
3. **The booster battery voltage must not exceed 12 volts.**

The following procedure must be followed exactly, being careful not to cause sparks.

1. Apply the handbrake, select Park and turn off all the vehicles electrical services.
2. Remove the luggage compartment floor panels.
3. Unclip the positive (+) terminal cover.
4. Attach one end of the red jump lead to the positive (+) terminal of the **booster** battery and the other end to the positive terminal of the discharged battery. **Make sure that a good connection is made. Do not allow the vehicles to touch.**

Continued

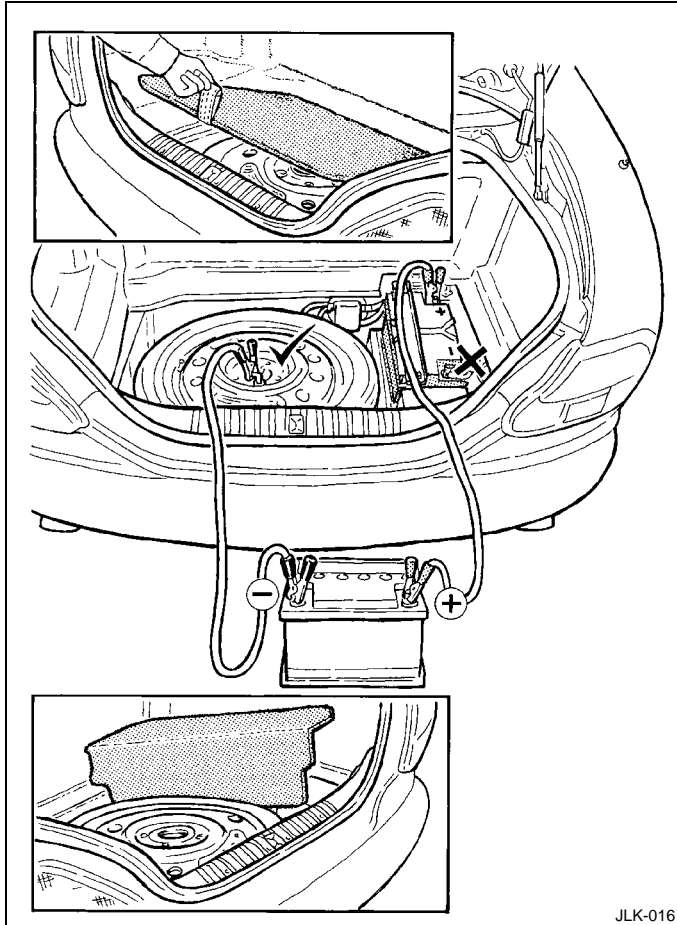

JLK-016

Caution: Do not connect the negative jump lead directly to the negative (-) terminal of the discharged vehicle.

5. Attach one end of the black jump lead to the negative (-) terminal of the **booster** battery and the other end to an earth point on the vehicle being started. (Use the spare wheel retaining bolt as shown.) The earth point must be at least 12 inches (305 mm) from the discharged battery. Make sure that a good connection is made.
6. When started allow the engine to idle for five minutes before disconnecting the cables.
7. Disconnect the black jump lead from the earth point and the booster battery negative (-) terminal. Disconnect the red jump lead from the positive (+) terminals of both batteries.

Note: Disconnection is done in the reverse order to the connecting procedure.

8. Refit the positive terminal cover and the floor panels.
9. Refit the luggage compartment floor panels.

4-10 Roadside emergency service

Vehicle Recovery

The preferred vehicle recovery method is by using a flat bed transporter or rear suspended tow. The front and rear towing eyes are primarily for emergency use when towing for SHORT DISTANCES, e.g. removing the vehicle if it is causing an obstruction or for winching the vehicle onto a recovery transporter.

Transporting

If the vehicle is being transported on a trailer or vehicle flat bed transporter, the handbrake must be applied, the wheels chocked and the gear selector lever moved to position 'N' or 'D' but NEVER to 'P'.

The vehicle must be securely tied down to the transporter or trailer. Do not attach tie-down hooks to the towing eyes.

Suspended Towing

Ensure that the recovery team follow these instructions:

Do not tow with sling type equipment since damage to the bodywork may result.

Caution: Do not tow vehicle by suspending the front end.

1. Remove the key from the ignition switch.
2. Raise the rear of the vehicle using a 'spectacle frame' type lifting device where a cradle is positioned under each rear wheel, as indicated.

Vehicles with Defective Automatic Transmission

The vehicle must be towed with the rear wheels clear of the ground.

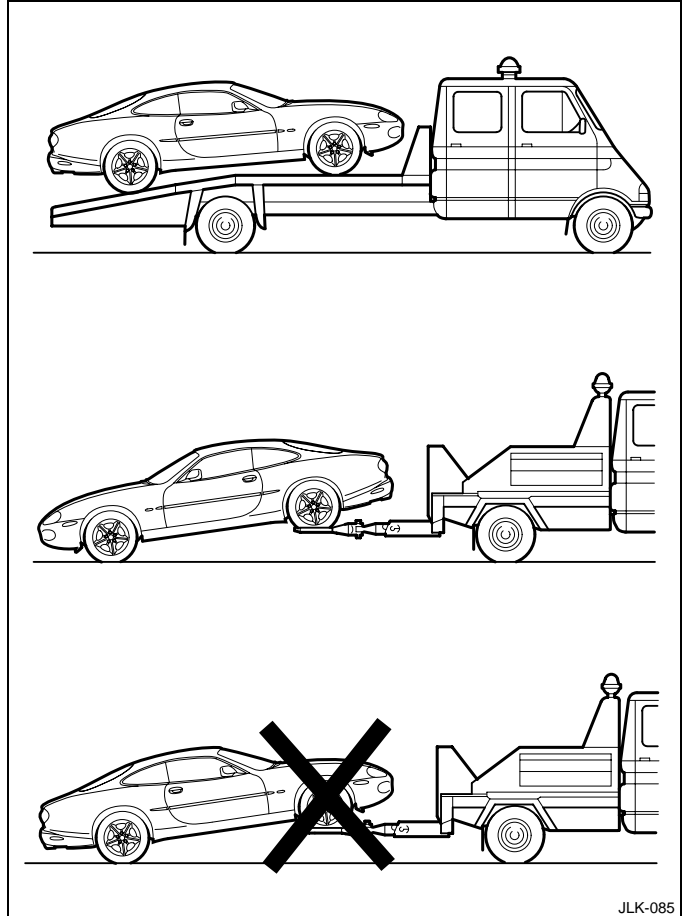

Towing Eyes



WARNING:

The vehicle must not be driven with a towing eye fitted to a front tow point.

Caution: The towing eyes are not suitable for 'solid bar towing'.

Care must be taken to avoid damaging the bumpers and front apron.



WARNING:

When the engine is not running the steering and brakes will no longer be power assisted. Therefore, be prepared for relatively heavy steering and the need for greatly increased brake pedal pressure.

A removable towing eye is provided for use at the front or rear of the vehicle. When not in use it is stowed with the jacking equipment kit see page 4-1.

Always obey towing regulations: In certain countries the registration number of the towing vehicle and an 'ON TOW' sign or warning triangle must be displayed in a prominent position at the rear of the vehicle being towed.

When being towed, the vehicle's gear selector lever must be in neutral (position 'N') with the ignition key turned to position 'II' to release the steering lock and render the indicators, horn and brake lights operational.

Vehicles may be towed for SHORT DISTANCES (maximum 0.5 miles/0.8 kilometres) with the gear selector lever in position 'N' provided a speed of 30 mph (48 km/h) is not exceeded.

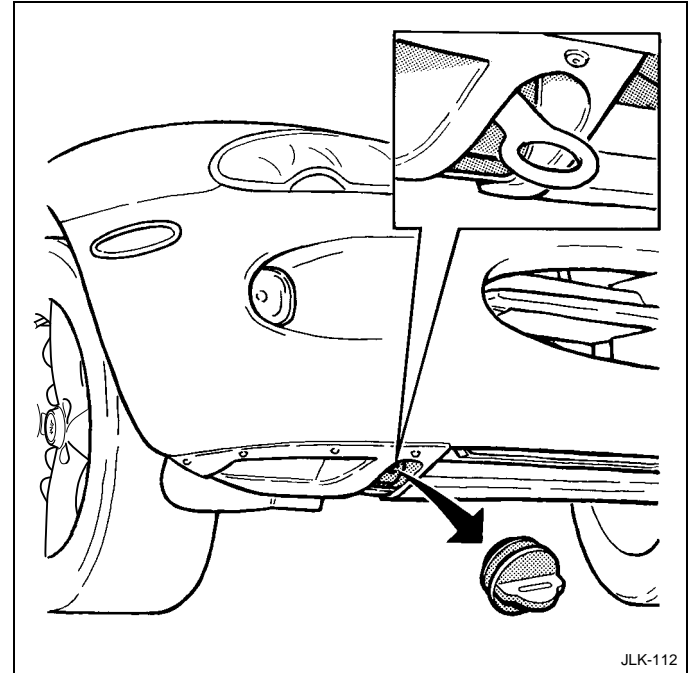

Front fitting: to use at the front of the vehicle, remove the rubber blanking plug from the front cross-member on the driver's side and screw the eye into the threaded drilling. The blanking plug is a push-fit in the towing eye thread.

4-12 Roadside emergency service

Rear fitting: to access the rear tow position, unclip the bumper cover by pulling the lower edge out slightly and then downwards. Screw the towing eye into the threaded body fixing. When refitting the cover, first insert the tab at the top of the cover before clipping the lower edge into position.

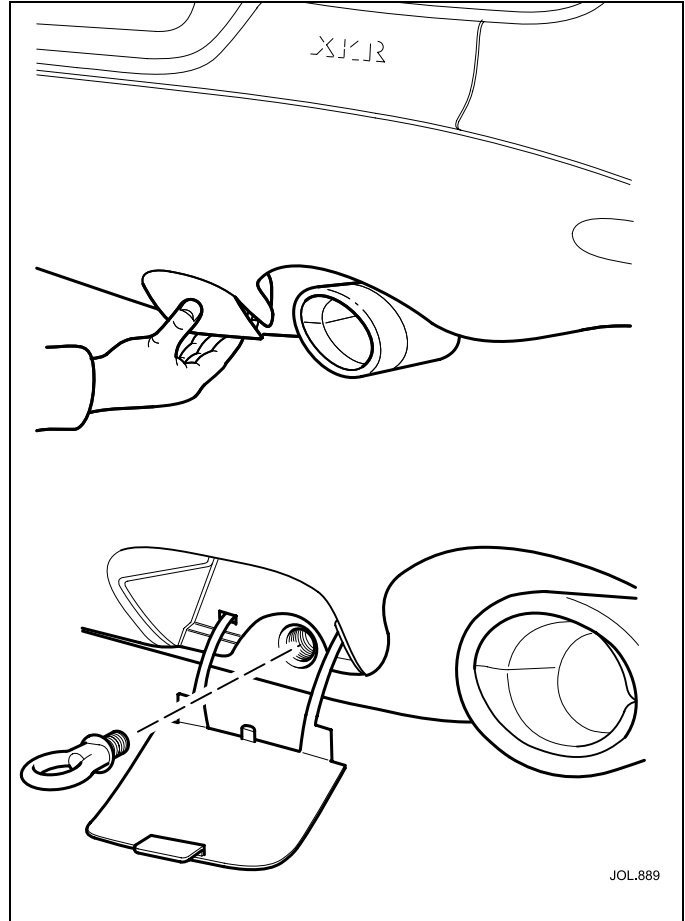

Fuses and Fuse Boxes

Fuse failure is signalled by an inoperative circuit.

Do not fit a new fuse if damage to the wiring is found; contact a Jaguar Dealer. After renewing a fuse have the circuit checked by a Jaguar Dealer.

Spare fuses and a special tool for removing the fuses are supplied underneath the electrical carrier lid in the luggage compartment.

Use only the spare fuses supplied. Replace the spare with a Jaguar approved fuse of the same amperage rating.

Checking and Renewing a Blown Fuse

Make sure the new fuse is the correct rating (amperage). Fuses are colour coded according to the amperage and the rating is also marked on each fuse. The colour code is as follows:

TAN	5 amp	CLEAR	25 amp
RED	10 amp	LIGHT GREEN	30 amp
LIGHT BLUE	15 amp	BRIGHT ORANGE	40 amp
YELLOW	20 amp		

Push the tool on to the suspect fuse and withdraw it.

If the wire in the fuse is broken, the fuse has blown.

A – Fuse in good condition.

B – Blown fuse.

Fit a new fuse using the tool.

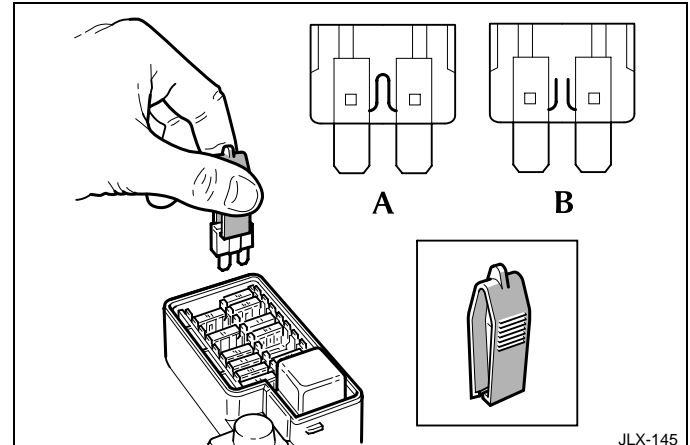
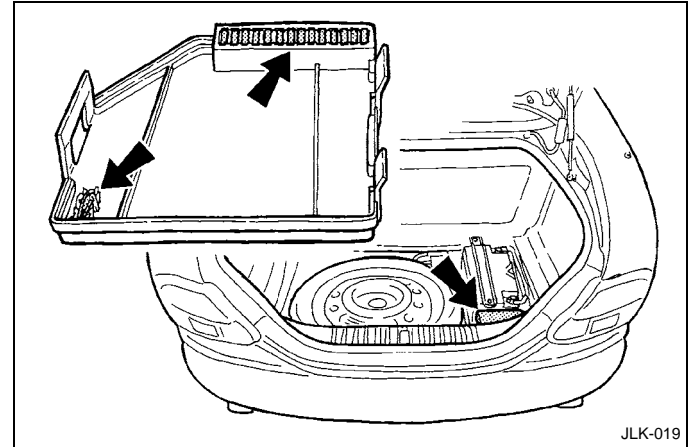

4-14 Roadside emergency service

Fuse Box Locations

There are five separate fuse boxes fitted to the vehicle, each one containing fuses protecting a different group of circuits.

The locations are as follows:

- A Engine compartment fuse box – Left-hand side, behind the windscreen washer reservoir.
- B Engine management fuse box - Passenger's side, within bulkhead extension.
- C Fascia fuse box – Passenger's side, on the end of the fascia behind the removable panel.
- D Fascia fuse box – Driver's side, on the end of the fascia behind the removable panel.
- E Electrical carrier fuse box – Luggage compartment.

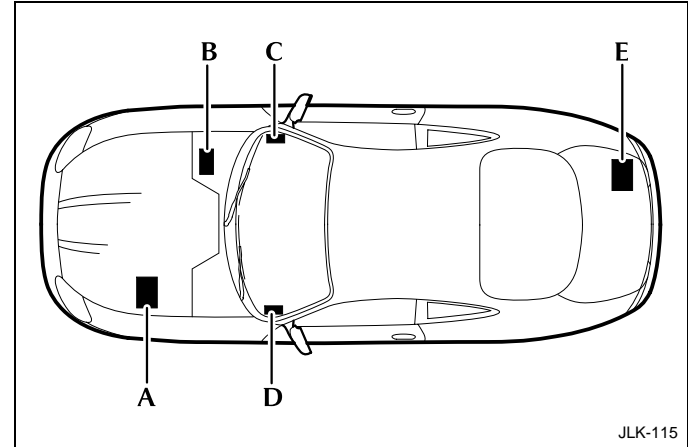

WARNING:

1. Do not fit a fuse of a different amperage from that specified on the Master Label. The electrical circuits may become overloaded with the subsequent possibility of a fire.
2. No attempt should be made to repair a fuse that has blown. This may cause a fire hazard or serious damage elsewhere in the electrical circuit.

Engine Compartment Fuse Boxes

There is one fusebox in the main engine compartment, located on the left-hand side, behind the windscreen washer reservoir.

Caution: When the fuse box lid is removed, take care to protect the box from moisture, and refit the lid at the earliest opportunity.

Remove the fusebox lid by pressing the retaining lugs and lifting.

When refitting, press the fuse box lid in the area of the retaining lugs until the lid engages.

The circuits protected are listed on page 4-20.



A second fusebox is situated within the bulkhead extension on the passenger's side.

Note: The bulkhead extension protects electrical components from the heat generated in the engine compartment.

Remove the fusebox lid by compressing and lifting the 'U' shaped latching mechanism (A).

To refit the fusebox lid, position into the slots and push down until the latching mechanism is engaged.

The circuits protected are listed on page 4-17.

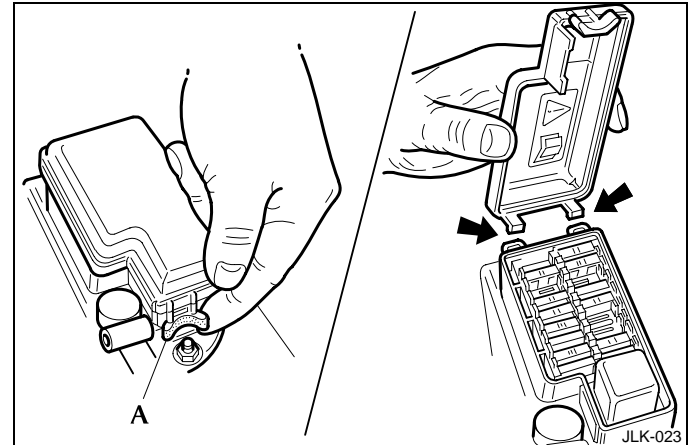

4-16 Roadside emergency service

Fascia Fuse Boxes

Fuseboxes are located at the extreme ends of the fascia, one on the driver's side and one on the passenger's side.

Pull the raised lip of the cover to access the fusebox.

The circuits protected are listed on page 4-18 and 4-19.

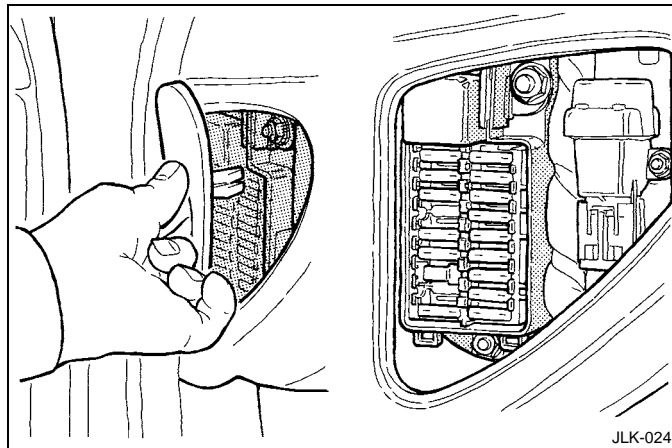

Luggage Compartment Fuse Box

A fusebox is located in the electrical carrier which is situated to the rear of the battery.

A list of protected circuits and fuse ratings is given on the fuse allocation chart (Master Label) which is attached to the lid of the electrical carrier.

Caution: When the carrier lid is removed, take care to protect the box from moisture ingress, and refit the lid at the earliest opportunity.

Remove the luggage compartment floor panel.

Remove the electrical carrier lid by pulling the retaining clips and pulling the lid upwards.

Spare fuses and a special tool for removing the fuses are supplied underneath the electrical carrier lid in the luggage compartment.

Reposition the lid and press down until the retaining clips engage.

The circuits protected are listed on page 4-21.

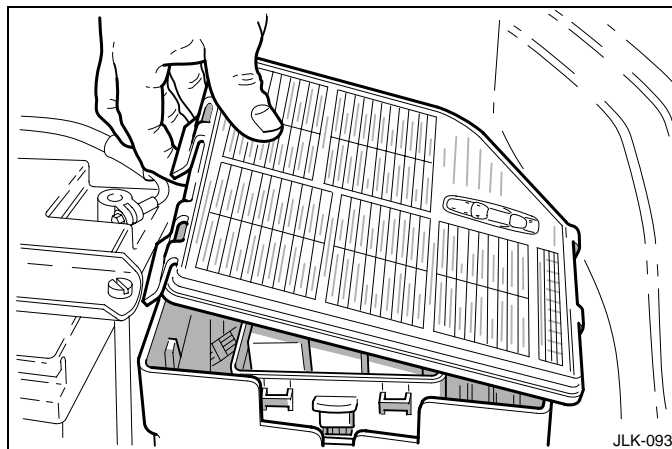

Fuse Ratings and Circuits

Engine Management Fusebox Front Passenger's Side – Within Bulkhead Extension

Fuse No	Ratings (amps)	Circuit
1	30	HO2 sensor heaters.
2	20	Intercooler water pump (Supercharged).
3	25	Starter solenoid.
4	5	Engine control module, transmission control module.
5	10	Injector supply.
6	–	Not used.
7	–	Not used.
8	10	Air conditioning compressor clutch.
9	30	Throttle motor.
10	5	Engine control module.

B on location illustration, page 4-14.

Fuse No	Ratings (amps)	Circuit
11	10	Adaptive cruise control smartbooster brake control module & relay.
12	10	Air flow meter, radiator fans control module, canister close valve, air assist control valve.
13	–	Not used.
14	10	HO2 sensor heaters relay (where fitted), EGR valve (where fitted), EVAP valve, ignition coils relay, throttle motor relay, AC compressor clutch relay.
15	30	Windscreen left-hand heater.
16	5	Engine control module cooling fan.
17	30	Windscreen right-hand heater.
18	10	Ignition coils supply.

4-18 Roadside emergency service

Fascia Fusebox – Driver's Side

Fuse No	Ratings (amps)	Circuit
1	20	Driver's seat control module.
2	10	Door mirror heaters.
3	30	Windscreen wiper motors and relays.
4	-	Not used.
5	15	Body processor module logic supply.
6	5	Centre console switches, key transponder module, convertible top header console.
7	15	Gearshift interlock solenoid, ignition keylock solenoid, interior lighting, windscreen washer pump.
8	10	Steering column adjustment, driver's seat switchpack, driver's headrest.
9	-	Not used.
10	5	Airbag.
11	20	Air conditioning drivers blower motor.

Fuse No	Ratings (amps)	Circuit
12	10	Door mirror heaters relay, Air conditioning: compressor lock, control module ignition supply, blower motor relays, power steering control module.
13	5	Diagnostic connector (battery).
14	10	Cruise control ON/OFF switch, main instrument cluster.
15	25	Driver's door control module, transit relay.
16	5	Electrochromic interior mirror (where fitted), windscreen heater relay, gear selector, transmission mode switch, J gate linear switch, rain sensing system.
17	10	Accessory sockets.
18	5	Main instrument cluster (includes clock).

D on location illustration, page 4-14.

Fascia Fusebox – Front Passenger’s Side

Fuse No	Ratings (amps)	Circuit
1	20	Passenger seat control module.
2	10	Door locking actuators.
3	–	Not used.
4	5	Door switchpacks, door locking.
5	5	Telephone transceiver and RT connector.
6	10	Air conditioning control module.
7	20	Steering column tilt and reach motors.
8	10	Passenger seat switchpack, passenger seat belt buckle switch, passenger headrest.
9	10	Radio/cassette head unit.
10	5	Telephone handset and transceiver.

Fuse No	Ratings (amps)	Circuit
11	20	Air conditioning passenger's blower relay.
12	5	Radio/cassette unit.
13	–	Not used.
14	20	Cigar lighter.
15	25	Passenger door control module, transit relay connector.
16	5	Navigation.
17	15	Exterior lights, high power sockets.
18	10	Dimmer control module.

C on location illustration, page 4-14.

4-20 Roadside emergency service

Engine Compartment Fusebox – Left-hand Side

Fuse No	Ratings (amps)	Circuit
1	10	Transmission control module.
2	5	Generator regulator.
3	5	Security sounder, headlamp levelling, ignition +Ve, centre console switchpack, adaptive cruise control.
4	5	ABS control module.
5	10	Starter relay, engine control module.
6	10	Right-hand dipped beam headlamp.
7	30	Power wash pump.
8	10	Left-hand dipped beam headlamp.
9	10	Security sounder.
10	–	Not used.
11	10	Right-hand horn.

Fuse No	Ratings (amps)	Circuit
12	30	Cooling fans series/parallel.
13	10	Left-hand horn.
14	30	Cooling fans parallel.
15	10	Air conditioning coolant pump.
16	30	ABS control valves.
17	15	Front fog lamps.
18	30	ABS pump motor.
19	10	Right-hand main beam headlamp.
20	–	Not used.
21	10	Left-hand main beam headlamp.
22	5	Adaptive cruise control module.

A on location illustration, page 4-14.

Luggage Compartment Fusebox – Electrical Carrier

Fuse No	Ratings (amps)	Circuit
1	5	Coupe: Reversing lamps. Convertible: Reversing lamps, rear quarter windows raise/lower relays.
2	20	Adaptive damping control module.
3	5	Fusebox ignition +Ve, bulb monitoring control module, S/C fuel pump relay, reversing aid.
4	5	Adaptive damping control module.
5	5	Diagnostic connector (ignition)
6	5	Right and left-hand stop lamps via bulb monitoring control module.
7	20	Fuel pump.
8	5	High mounted stop lamp.
9	10	Antenna motor.
10	10	Security and locking control module.
11	10	Accessory sockets
12	– 20	Coupe: Not used. Convertible: Right-hand rear quarter window lift motor

Fuse No	Ratings (amps)	Circuit
13	–	Not used.
14	– 40	Coupe: Not used. Convertible: Raise and lower pump for convertible top.
15	10	Rear fog lamps.
16	5	Navigation.
17	25	Heated rear screen.
18	30	Power amplifier.
19	5	Right-hand tail, left-hand and right-hand number plate lights.
20	– 20	Coupe: Not used. Convertible: Left-hand rear quarter window lift motor
21	5	Left-hand tail, left-hand and right-hand stoneworker lights.
22	20	Supercharger fuel pump.

E on location illustration, page 4-14.

4-22 Roadside emergency service

Control Modules – Identification and Location

Control Module	Location
Adaptive Damping	Luggage compartment, rear, right of the spare wheel well.
Airbag (Supplementary Restraint System)	Fascia right-hand side. Behind the glove compartment liner or the driver's knee bolster.
Anti-lock Braking System and Traction Control	Engine compartment, driver's side. Mounted below the ABS hydraulic control unit.
Body Processor	Fascia, mounted on passenger airbag bracket.
Climate Control	Fascia, right-hand side of the climate control unit.
Dimmer	Fuse box on the right-hand end of the fascia.

Control Module	Location
Driver's Door	Driver's door, forward of the glass guide above the speaker.
Driver's Seat	Driver's seat cushion frame.
Engine Management	Engine compartment, passenger side, within bulkhead extension.
Passenger's Door	Passenger's door, forward of the glass guide above the speaker.
Passenger's Seat	Passenger's seat cushion frame.
Security and Locking	Luggage compartment electrical carrier to the rear of the battery.
Transmission	Engine compartment, passenger side, within bulkhead extension.

Relay Identification and Location

The following chart identifies and gives locations for the relays which control the vehicle's electrical services. The relays have coloured harness connectors and cases for identification. Where the connector colour differs from the case, both colours will be listed (connector colour first).

Relays, where not mounted in a fuse box, are arranged in groups of three. Each group has a black plastic cover, which slots into the harness connector and can be easily removed for access.

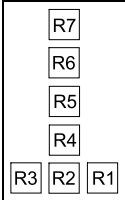
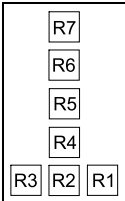
	Functions	Case Colour
Engine compartment fusebox, left-hand side, to the rear of the windscreen washer reservoir.	Layout as diagram: R1 Air conditioning water pump. R2 Front fog lamps. R3 Main beam headlamps. R4 Power wash (where fitted). R5 Dipped beam headlamp. R6 Horn. R7 Ignition.	 Brown Brown Brown Brown Brown Brown Brown
Luggage compartment fusebox to the rear of the battery, under the electrical carrier lid.	Layout as diagram: R1 Rear fog lamps. R2 Heated rear window. R3 Tail and number plate lights. R4 Fuel pump. R5 Stop lamps. R6 Accessory socket (Dealer fit option). R7 Ignition.	 Brown Brown Brown Brown Brown Brown Brown

4-24 Roadside emergency service

Relay Identification and Location (continued)

	Functions	Case Colour
Luggage compartment to the rear of the battery, under the electrical carrier lid. Note: Micro relays operate rear quarter window functions.	Right to left: Rear quarter windows up (nearest) and down, right-hand side. S/C secondary fuel pump. Rear quarter windows up (nearest) and down, left-hand side. Convertible top lower. Convertible top raise. Spare.	2 x Black Brown 2 x Black Black Black –
Driver's side fuse box at the end of the fascia.	Ignition.	Brown
Passenger's side fuse box at the end of the fascia.	Auxiliary.	Brown
Engine management fuse box, passenger side within bulkhead extension.	Engine management system control.	Brown
Engine compartment right-hand side, within bulkhead extension.	From front of vehicle to rear: Starter. Left-hand front screen heater (If fitted). Right-hand front screen heater (If fitted). Intercooler water pump HO2 sensor heaters relay	Brown Brown Brown Brown Brown

	Functions	Case Colour
Engine compartment passenger side, within bulkhead extension.	Looking forward from right to left: Ignition coil. Throttle motor power. Pl main (injectors).	Brown Brown Brown
Engine compartment left-hand side within bulkhead extension.	From front of vehicle to rear: Air conditioning clutch. Wiper on/off. Wiper fast/slow.	Brown Black Black
Behind the fascia on the left-hand side as viewed from the rear of the car.	Door mirror heater: micro-relay.	Black
Behind the fascia on the right-hand side as viewed from the rear of the car.	From front of vehicle to rear: Door lock: micro-relay. Air conditioning isolate: micro-relay.	Black Black
Footwell, mounted on the left-hand side of the transmission tunnel.	From front of vehicle to rear: Left-hand blower: micro-relay. Right-hand blower: micro-relay	Black Black
Engine compartment left-hand side, below the headlamp.	Cooling fans: large relay.	Black

4-26 Roadside emergency service

Fire extinguisher

Many countries make it compulsory to carry a fire extinguisher. Your Jaguar Dealer can supply and fit one.

Mexican vehicles have a factory fitted fire extinguisher which contains 2.2lbs (1 kg) of BC powder pressurised with nitrogen to a working pressure of 180 psi (12 bar) at 68°F (20°C).

This extinguisher can be used on liquid fires, electrical equipment fires and, if no explosion risk, gaseous fires.



WARNING:

Do not test the fire extinguisher prior to use. Partial discharge will render the extinguisher inoperative.

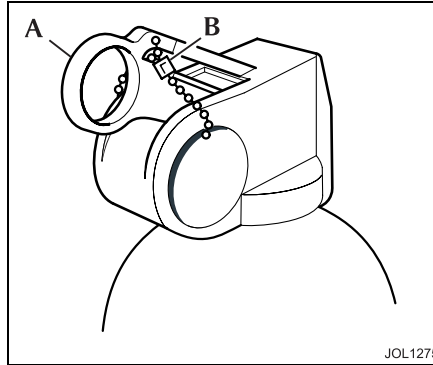

To operate the fire extinguisher:

1. Unclip and remove the extinguisher from the bracket.
2. Put your finger through the yellow safety wedge ring (A) and pull hard to remove the wedge. The operating lever will be exposed.
3. Hold the extinguisher upright and aim at the base of the fire.
4. Press the lever down firmly.
5. Release the lever to stop the flow of powder.

Maintenance

Every six months:

- Remove the extinguisher from its bracket and check that the nozzle is clear.
- Check that the safety wedge strap (B) is secure.
- Check the pressure gauge on the base of the extinguisher. If the gauge is in the red area report it to your Jaguar Dealer immediately as the extinguisher may not work in an emergency.

Introduction

Owners are responsible for ensuring that the vehicle is regularly serviced at the correct mileage/time intervals as specified in the 'Maintenance Schedules'. The first part of this section deals with regular servicing.

The condition of the tyres is of the utmost importance. Advice about tyre wear and correct usage is given in this section. If in any doubt about the condition of your tyres, contact a Jaguar Dealer.

Regular Servicing

Each vehicle is given a full 'Pre-Delivery Inspection' to ensure that all systems function correctly and the vehicle meets its specification.

Regular maintenance and servicing is the responsibility of the owner. Jaguar Dealers will be pleased to arrange periodic servicing in accordance with the USA/Mexico '**Passport to Service**' Booklet or Canadian '**Club Jaguar**' Warranty and Benefits Information Booklet. Refer also to section 1: Scheduled Maintenance.

Failure to implement maintenance at the recommended intervals could result in deterioration of vehicle performance and possible infringement of regulations.

Tyres

Tyres of the correct type and dimensions, with correct cold inflation pressures are an integral part of every vehicle's design. Regular maintenance of tyres contributes not only to safety, but to the designed function of the vehicle. Roadholding, steering and braking are especially vulnerable to incorrectly pressurised, badly fitted or worn tyres.

Tyres of the correct size and type but of different make have widely varying characteristics. It is therefore recommended that Jaguar approved tyres (see Section 6: **Wheel/Tyre Data**) are fitted to all wheels.

Do not interchange tyres from side to side, front to rear or vice versa as tyre wear produces characteristic patterns depending upon their position and, if the position is changed after wear has occurred, the performance of the tyre will be adversely affected.

Note:

1. On certain models the rear wheel and tyre assemblies will be larger than the front. These larger assemblies must never be fitted to the front of the vehicle.
2. On certain models the tyres specified may be of a directional type. These tyres must be fitted so that when viewed from the side of the vehicle the tyre 'direction of rotation' arrow points in the vehicle direction, when positioned at the top of the tyre.

Tyre Repair

It is recommended that damaged tyres are discarded and new tyres fitted. They must not be repaired in view of the high performance capability of the vehicle.

5-2 Vehicle maintenance

Tyre Use After Vehicle Storage

After a long period of a vehicle standing, tyres may become locally distorted with a flat area. This will cause an uneven ride for a few miles until the tyres have warmed up and the 'flat' rounds off.

However, to reduce the effects of flat-spotting, the tyres of a stored vehicle may be inflated to 44 lb/in² (300 kPa).

Refer to Section 6, **Recommended Tyre Pressures** for normal operating pressures.

Tyre Size, Type, Pressures

The tyre pressures recommended (see Section 6: **Wheel/Tyre Data**) provide optimum ride and handling characteristics for all normal operating conditions. The pressures should be checked, and correctly set, if necessary, once per week. This should be done with the tyres cold. Tyre temperatures and pressures increase when running. Deflating a warm tyre to the recommended pressure will result in under inflation which may be dangerous.

A slight natural pressure loss occurs with time. If this exceeds 2 lb/in² (14 kPa) per week, the cause should be investigated and rectified.

It is an offence in many States and certain other countries to drive a vehicle with tyres that are not inflated in accordance with the vehicle's proper use.

A vehicle fitted with winter tread tyres must only be driven at speeds below the figure moulded into the tyre's side wall. If no figure is shown, drive only at moderate speed.

Tyre Renewal

When renewal of tyres is necessary it is preferable to fit a complete vehicle set. Should either front or rear tyres only show need for renewal, new tyres must be fitted, as axle sets, to replace worn ones.

Note: After new tyres have been fitted the wheels need to be dynamically balanced.

The radial ply tyres specified are designed to meet the high speed performance capability of this vehicle.

Only tyres of identical specification as shown in Section 6: **Wheel/Tyre Data** must be fitted. Do not fit tyres with a different tread pattern, size or speed rating.

Damage

Excessive local distortion can cause the casing of a tyre to fracture and may lead to premature failure. Tyres should be examined especially for cracked walls, exposed cords, etc. Flints and other sharp objects must be removed from the tyre tread; if left in they may work through the cover. Clean off any oil or grease contamination by using a suitable cleaner.

Caution: Do not use paraffin (kerosene), which has a detrimental effect on rubber.

Wear

All tyres fitted as original equipment include tread wear indicators (TWI) in their tread pattern. When the tread has worn to a remaining depth of 0.063 inch (1,6 mm) inch the indicators appear at the surface as bars which connect the tread pattern across the full width of the tyre.

It is illegal in many States and certain other countries to continue to use tyres after the tread has worn to less than 0.063 inch (1,6 mm) over three quarters of the width and the entire circumference of the tyre.

It should be noted that the properties of many tyres alter progressively with wear. In particular the 'wet grip' and aquaplaning resistance are gradually but substantially reduced. Extra care and speed restriction should therefore be exercised on wet roads as the effective tread depth diminishes.

Incorrect wheel alignment will accelerate tyre wear. Fins on the inner or outer edges of the tread pattern are caused by excessive toe-in or toe-out respectively. As fins may also be caused by high cornering speeds or road camber, it is advantageous to have the cause detected by having the wheel alignment checked.

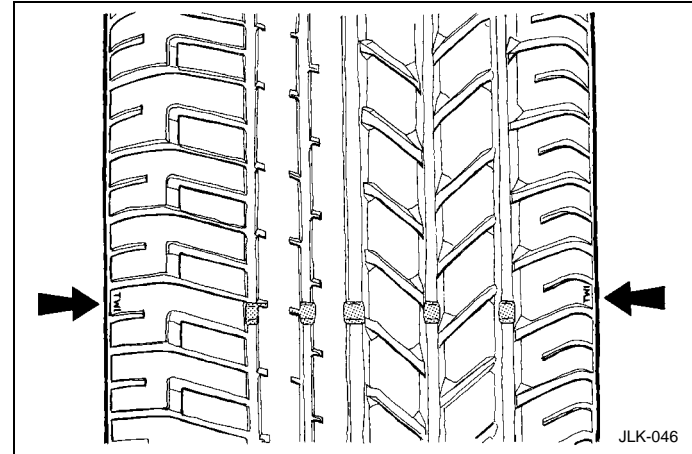

5-4 Vehicle maintenance

Snow Chains and Spikes Spiders

Snow chains, of the recommended type, may be fitted **only** when using 17 inch roadwheels with 245/50 ZR17 tyres. Spikes spiders may be fitted up to a maximum of 18 inch diameter roadwheels. Snow chains or spikes spiders must be fitted to the **rear wheels only**. Contact your Jaguar Dealer for details and availability of approved snow chains or spikes spiders.

Note: Traction control (if fitted) MUST be switched OFF when using snow chains or spikes spiders.

The maximum speed when using snow chains or spikes spiders is 30 mph (48 km/h).

Remove the snow chains or spikes spiders immediately the roads are clear of snow.

Ensure the fitting instructions supplied with the snow chains or spikes spiders are kept in a safe place, for example, the Vehicle Care literature pack.

Care of Wheels

The wheels are covered with a protective coating. To prevent corrosion it is essential that this coating is not damaged.

When removing or fitting tyres always advise the tyre fitter to treat the wheels with great care and to only use equipment with spigot or stud hole clamping. The equipment must not have any moving parts which contact the wheel, and tyre levers must not be used.

Always ensure that the wheel nuts are fully seated before finally tightening the nuts in alternate sequence.

United States Department of Transportation/Uniform Tyre Quality Grades.

The following information relates to the tyre grading system developed by the National Highway Traffic Safety Administration which will grade tyres by tread wear, traction and temperature performance.

Tread wear

The tread wear grade is a comparative rating based on the wear rate of the tyre when tested under controlled conditions on a specified government test course. For example, a tyre graded 150 would wear one and a half (1½) times as well on the government course as a tyre graded 100. The relative performance of tyres depends upon the actual conditions of their use, however, and may depart significantly from the norm due to variations in driving habits, service practices and differences in road characteristics and climate.

Traction grades

The traction grades, from the highest to the lowest are AA, A, B and C, and they represent the tyre's ability to stop on wet pavements as measured under controlled conditions on specified government test surface of asphalt and concrete. A tyre marked 'C' may have poor traction performance.



WARNING:

The traction grade assigned to this tyre is based on braking (straight ahead) traction tests and does not include cornering (turning) traction.

Temperature grades

The temperature grades 'A' (the highest), 'B' and 'C' represent the tyre's resistance to the generation of heat and its ability to dissipate heat when tested under controlled conditions on a specified indoor laboratory test wheel. Sustained high temperature can cause the material of the tyre to degenerate and reduce tyre life, and excessive temperature can lead to sudden tyre failure.

The grade 'C' corresponds to a level of performance which all passenger car tyres must meet under the Federal Motor Vehicle Safety Standard N^o. 109.

The Grade 'B' and 'A' represent higher levels of performance on the laboratory test wheel than the minimum required by law.



WARNING:

The temperature grade for this tyre is established for a tyre that is properly inflated and not overloaded.

Excessive speed, under-inflation or excessive loading, either separately or in combination, can cause heat build-up and possible tyre failure.

5-6 Vehicle maintenance

Battery

A low maintenance battery specifically designed for use with this vehicle is fitted in the luggage compartment.

Under normal operating conditions the battery requires minimal maintenance. However, in hot weather conditions it is advisable to check the battery electrolyte levels at regular intervals.



1. **The cell plugs and vent pipe must be in place at all times when the battery is in the vehicle. Failure to fit, or incorrect fitting of these items is potentially hazardous.**
2. **To avoid injury do not use an open flame or cause an electric spark when checking the battery. Hydrogen gas generated by the battery is flammable and may explode.**
3. **Do not connect any 12 volt equipment (for example, a 12 volt lead lamp), directly to the battery terminals. Use the cigar lighter socket for temporarily connecting Jaguar approved accessories.**
4. **Do not let battery acid come into contact with skin or eyes. If you get electrolyte in your eyes or on your skin, immediately rinse with cold water and consult a doctor.**
5. **California Proposition 65: battery posts, terminals and related accessories contain lead and lead compounds. Wash your hands after handling.**

Caution:

1. **Switch off current before disconnecting battery terminals. Always disconnect the earth terminal first and reconnect last.**
2. **Do not let battery acid come into contact with painted surfaces or fabric.**

The exterior of the battery should be occasionally wiped clean to remove any dirt or grease.

If a new battery is to be fitted, it must be the same type as the original. The use of unapproved batteries is not recommended and could invalidate the vehicle warranty.

Note:

1. The service life of the battery is dependent on its condition of charge. It must always be sufficiently charged for the battery to last an optimum length of time.
2. We recommend that the battery charge is checked frequently if the vehicle is used mostly for short distance trips, or if it is not used for long periods of time.

Generator

To prevent damage to the generator, do not run the engine while the battery or any of the charging circuit cables are disconnected.

The generator has polarity sensitive components that may be irreparably damaged if subjected to incorrect polarity. Ensure that the battery earth lead is always connected to the battery negative (-) terminal.

Check/Top Up Battery Electrolyte

Note: In normal climates this must be carried out at least once a year. In hot weather/climates the electrolyte level must be checked at least every three months.

Remove the luggage compartment floor panel and the right-hand side panel.

Unscrew the six cell plugs. Check that the electrolyte is level with the plastic level indicator (A). If necessary, top up with distilled water but do not overfill. If illumination is required, use a hand-held flashlight to inspect the electrolyte level.

Refit the six cell plugs.

Refit the floor panels.

Battery Charging



WARNING:

Batteries produce combustible gas (hydrogen) when being charged. The battery must be removed from the vehicle before charging commences.

To disconnect the battery, refer to **Battery Lead Disconnection** on page 5-8.

When charging the battery ensure that the charge voltage is the same as the nominal voltage of the battery.

Switch off the charger before connecting or disconnecting terminal connections to avoid sparks and short circuits.

Ensure that the charger positive (+) lead is connected to the positive (+) terminal of the battery and the negative (-) lead is connected to the negative (-) terminal of the battery.

Do not remove or loosen any of the cell plugs when charging the battery.

Check, and if necessary top-up the electrolyte level when the battery is fully charged.

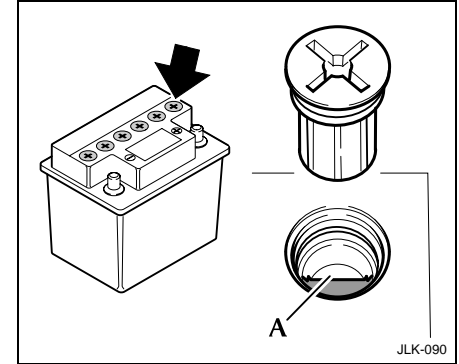

Clean and Grease Battery Connections

Disconnect the battery leads as detailed in battery disconnection on page 5-8.

Clean the battery posts and coat the post bases with petroleum jelly.

Reconnect the battery leads as detailed in battery connection on page 5-8.

5-8 Vehicle maintenance

Battery Lead Disconnection

Note: Upon battery disconnection, both trip computer memories (A and B) will be erased. On reconnection the radio will require recoding and the clock will need to be reset.

Caution:

1. Under no circumstances should a battery be disconnected whilst the ignition circuit is live, as permanent damage to the instrument pack may occur.
2. Leave windows partially open if access to the vehicle interior is required (automatic window drop for door opening will not function with battery disconnected).
3. Disconnect the negative lead (earth terminal) first.



WARNING:

California Proposition 65: battery posts, terminals and related accessories contain lead and lead compounds. Wash your hands after handling.

Remove the luggage compartment floor panel and the right-hand side panel (where fitted).

Unclip the battery positive terminal cover.

Slacken the **negative** lead pinch bolt (10 mm spanner required) and disconnect the **negative** (-) battery lead. Slacken the **positive** lead pinch bolt and disconnect the **positive** (+) battery lead.

Battery Lead Connection

Whenever either or both battery cables are disconnected, a **minimum of 30 seconds MUST** elapse between disconnection of the first cable and reconnection of the last cable.

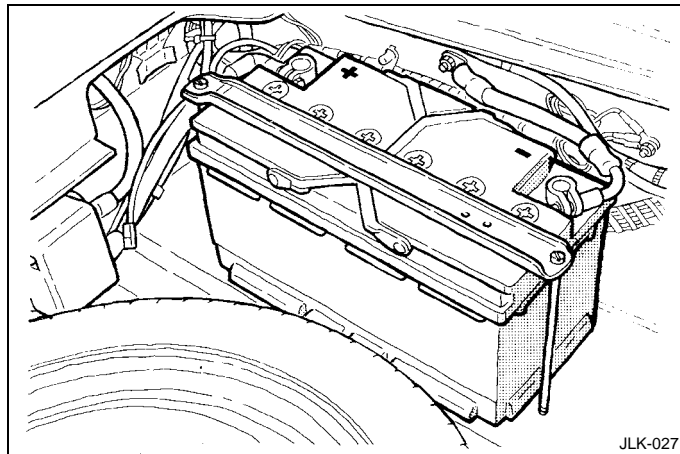

A 'clean' final reconnection must always be made. Should the cable make temporary contact only, wait another 30 seconds before making the final reconnection.

Caution: Do not over tighten the pinch bolts.

Connect the **positive** (+) lead, tighten the pinch bolt and clip the positive terminal cover on the battery.

Connect the **negative** (-) lead and tighten the pinch bolt.

Refit the floor panels.

After the battery has been reconnected and the ignition switch is turned to position 'II', the message centre display will initially show an erroneous reading i.e. -----. This will remain until after the bulb check sequence, when the correct recorded mileage will be displayed.

This is a normal function of the instrument pack.

Battery Lead Connection (continued)

Note: After battery disconnection, the door windows need to be reprogrammed to 're-learn' the upper and lower limits of travel. This simple procedure is explained fully in the Driver's Handbook, Section 3.

Reset the clock to the correct time.

The radio cassette player display will indicate 'code'. The radio will not operate until the correct security code has been re-entered. Refer to the Sound System Handbook.

Bulb Renewal

It is important that only Jaguar bulbs of the type specified on page 5-16 are used when renewing bulbs.

Before renewing bulbs, switch off the ignition and light switches.

Front Fog Lamp – Bulb Renewal

It is recommended that the front fog lamp bulbs are renewed by a Jaguar Dealer.

Headlamp – Bulb Renewal

Caution: These bulbs are halogen types and will be damaged if touched by hand or contaminated with oil or grease. It is important to use clean gloves or cloth when handling a bulb which is to be used again. A contaminated bulb may be cleaned with methylated spirit before refitting.

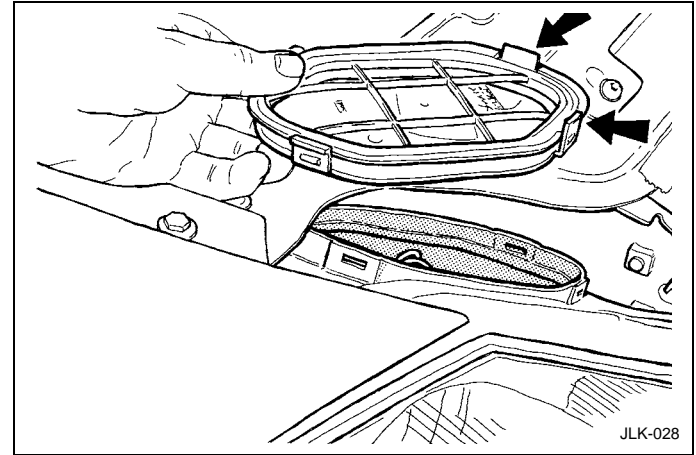

Main Beam, Front Direction Indicator and Side Light Access

Access to the headlamp unit for main beam, front direction indicator and side light bulb renewal, is through the clear hexagon cap at the rear of the headlamp unit.

Open the hood and remove the hexagon cap by squeezing the two lower clips, arrowed above.

When refitting the hexagon cap make sure the seal is in place.

5-10 Vehicle maintenance

To change any of the bulbs shown on this page, first remove the hexagon access cap as described on page 5-9.

Main Beam – Bulb Renewal (A)

Rotate the bulb holder anticlockwise by a quarter of a turn to remove from the headlamp unit. Lift the plastic spring clips (B) and remove the bulb assembly from the harness connector. Remove the bulb and fit a new one of the correct type, see page 5-16. Refit the bulb assembly to the harness connector. Refit the assembly into the headlamp unit.

Front Direction Indicator – Bulb Renewal (C)

Turn the direction indicator bulb holder a quarter turn and remove.

Remove the bulb and fit a new one of the correct type, see page 5-16.

Front Parking (Side) Light – Bulb Renewal (D)

Rotate the bulb holder a quarter turn and remove from the headlamp.

Pull the bulb from the holder and fit a new one of the correct type, see page 5-16.

Reposition the bulb holder in the headlamp unit and rotate a quarter turn.

Refit the hexagon access cap as described on page 5-9.

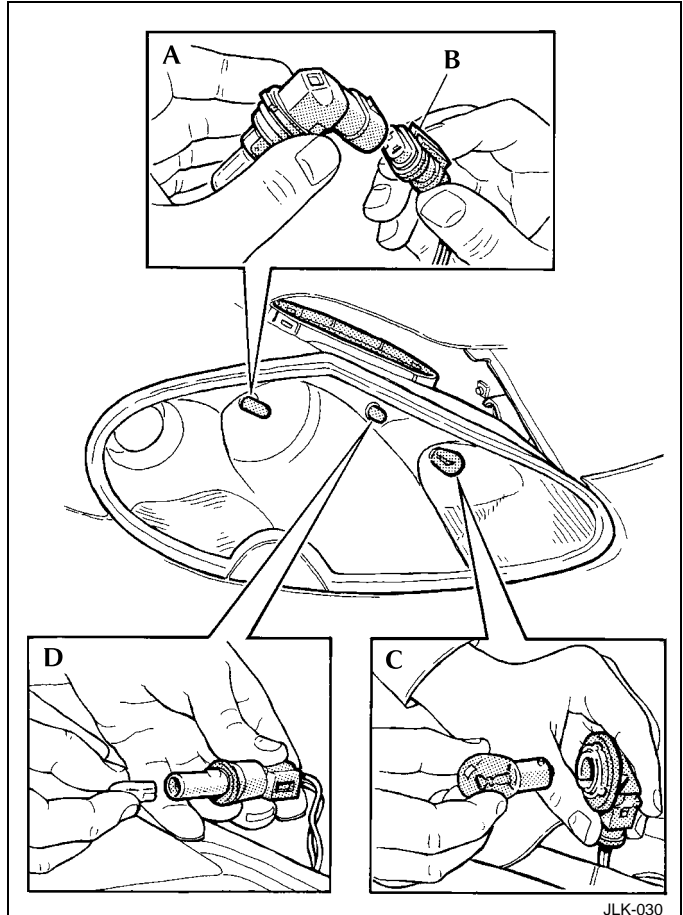

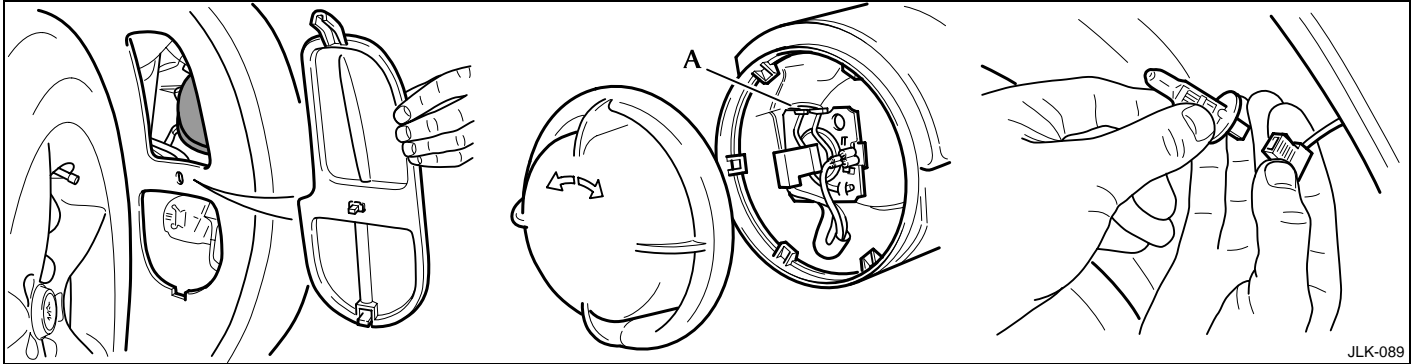

Dip Beam Bulb Access

Access to the dip beam bulb is as follows:
Turn the front wheels to allow free access to the wheel arch.

Remove the wheel arch access panel by rotating the centre fastener and lifting the lower retaining clip.

Turn the cap at the back of the dip beam a quarter turn anticlockwise and remove.

When refitting the cap make sure the seal is in place.

Dip Beam – Bulb Renewal

Push the spring retainer (A) to the right and rearwards to release. Remove the bulb holder.

Remove the bulb and fit a new bulb of the correct type, see page 5-16.

Refit the bulb holder and the spring retainer.

5-12 Vehicle maintenance

Rear Light Assembly -Bulb Renewal

Ensure that the lights and ignition switch are OFF before removing any bulbs. Open the luggage compartment.

Unscrew the two fasteners securing the light assembly cover (top figure). Remove the cover, noting the cover locating pin.

Press the release bar on the electrical connector (centre figure) and carefully pull off the connector. Unscrew the knurled nut securing the bulb carrier and remove the carrier.

The left-hand bulb carrier is shown and the bulbs fitted are:

- Direction indicator (A).
- Reversing light (B).
- Fog light (C).
- Tail light (D).
- Stop and tail light (E).

Remove the faulty bulb and fit a new one of the correct type, as specified on the bulb carrier and the bulb chart (see page 5-16).

Note that 12V, 21W/5W stop/tail bulbs are fitted in positions E and D but the stop light in position D is not used.

Refit the bulb carrier and secure with the knurled nut. Carefully plug in the electrical connector.

To refit the rear cover, insert the cover locating pin, close the cover and secure with the two screw fasteners.

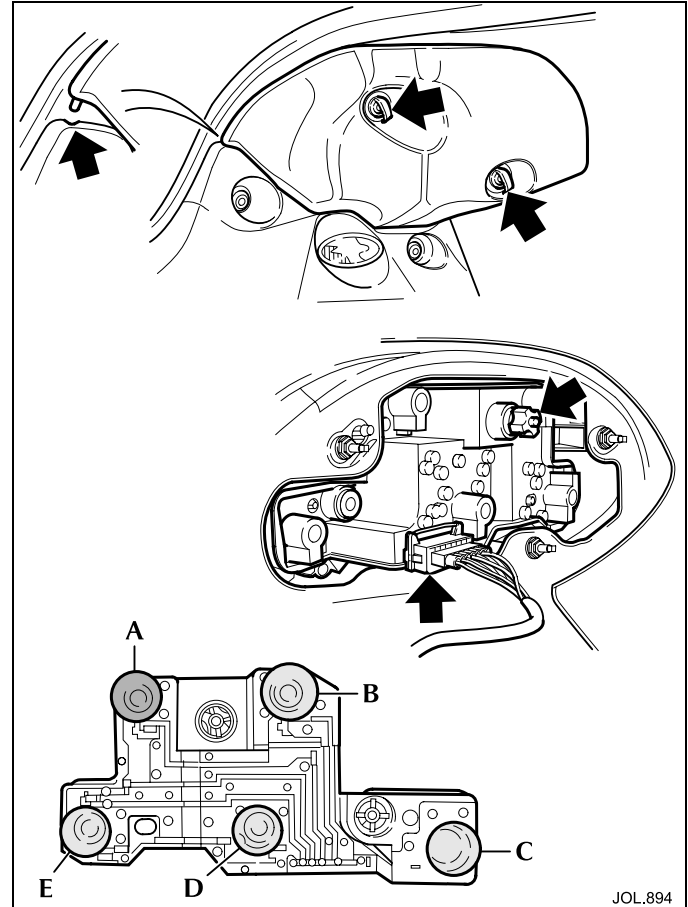

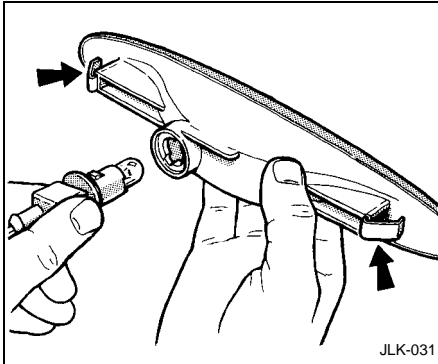

JLK-031

Side Marker Light – Bulb Renewal

To remove the side marker lenses it is necessary to compress the spring clips at the back of the lens. Access to the rear of the **front** side marker is through the wheel arch access panel.

To access the back of the **rear** side marker It is necessary to reach up behind the bumper cover. Because of the proximity of the exhaust system, make sure the exhaust is cold when renewing the rear side marker bulb.

Twist the bulb holder anti-clockwise and remove. Pull out the bulb and fit a new one of the correct type, see page 5-16.

Refit the bulb holder.

Press the unit into place in the front wing/ bumper cover.

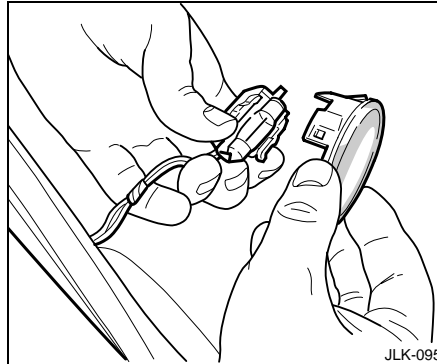

JLK-095

Luggage Compartment Light – Bulb Renewal

Carefully prise the light unit from the luggage compartment trim panel. Lightly squeeze the clear toggles on both sides of the bulb to remove the lens.

Fit a new bulb of the correct type, see page 5-16.

Refit the lens.

Refit the light unit to the luggage compartment trim panel.

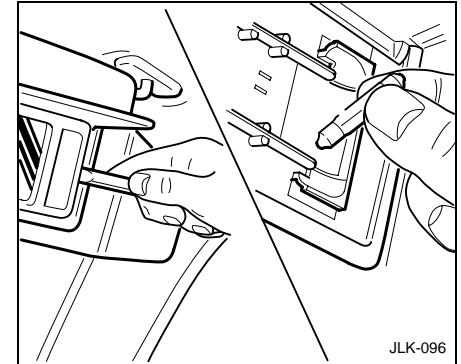

JLK-096

Sun Visor Vanity Mirror Light – Bulb Renewal

Swing the sun visor down and lift the vanity mirror flap. Using a screwdriver carefully prise the mirror/lens assembly from the sun visor. Remove the bulb from the holder and fit a new one of the correct type, see page 5-16.

Refit the mirror/lens.

5-14 Vehicle maintenance

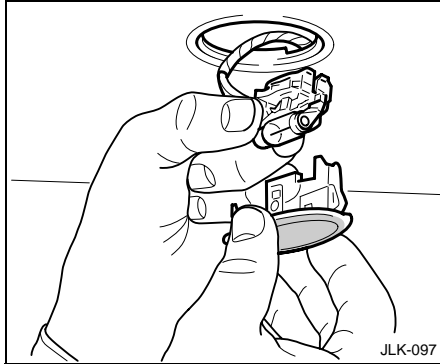

Interior Roof Light (Coupe Only) – Bulb Renewal

Carefully prise one end of the light unit from the roof and remove. Lightly squeeze the clear toggles on both sides of the bulb to remove the lens.

Remove the bulb and fit a new one of the correct type, see page 5-16.

Refit the lens.

Refit the light unit back into the roof.

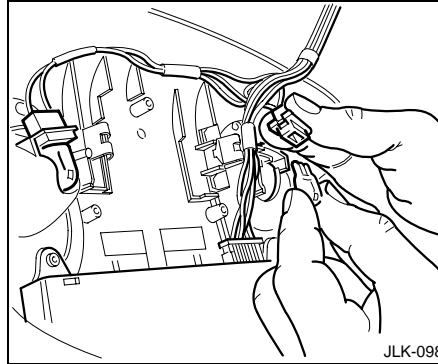

Roof Console Courtesy and Map Light – Bulb Renewal

Carefully remove the roof console from the trim panel. (The console is a pull/push fit.)

Remove the bulb holder.

Remove the bulb and fit a new one of the correct type, see page 5-16.

Refit the bulb holder.

Refit the roof console by carefully pressing into position in the trim panel.

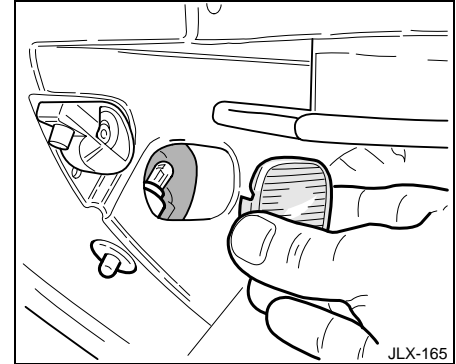

Glove Box Light – Bulb Renewal

Open the glove box and carefully prise the lens from the left-hand side of the glove box.

Remove the bulb from the bulb holder and fit a new one of the correct type, see page 5-16.

Refit the lens into the glove box.

Footwell Light – Bulb Renewal

Press the light unit forward against the spring and carefully prise out the edge of the unit to allow its removal.

Remove the bulb holder.

Remove the bulb and fit a new one of the correct type, see page 5-16.

Refit the light unit.

Door Guard Light – Bulb Renewal

Remove the red/clear lens by inserting a flat blade screwdriver through the access hole at the bottom of the lens, to disengage the clip leg, then slide the lens down.

Remove the bulb and fit a new one of the correct type, see page 5-16.

Refit the lens.

Number Plate Light – Bulb Renewal

A special tool is required to remove the trim to give access to the number plate light. It is recommended that number plate bulb is renewed by a Jaguar Dealer.

High Mounted Stop Light – Interior and Exterior – Renewal

Both types of high mounted stop lights have 16 LEDs. Should one or more of these LEDs fail, then the unit may cease to meet legal requirements and must be renewed immediately by a Jaguar Dealer.

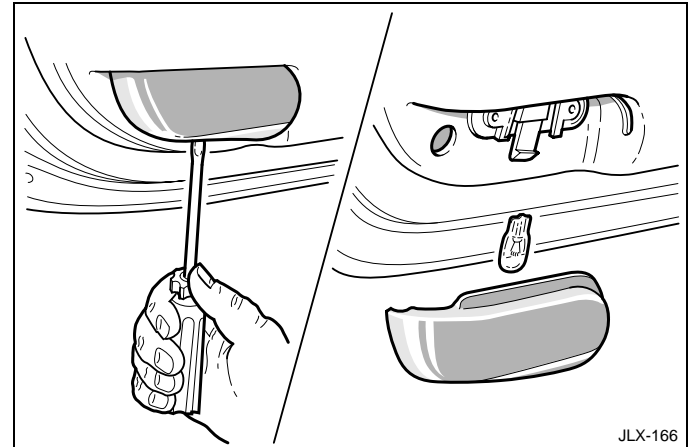
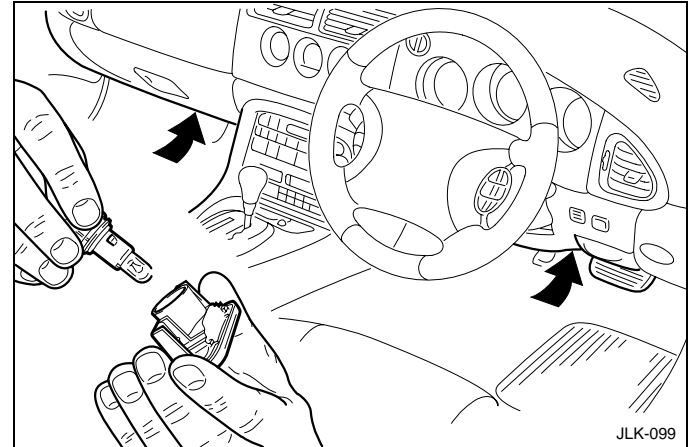

5-16 Vehicle maintenance

Bulb Chart

Description	Capacity	Type
Door guard light.	12V 5W	Capless long life.
Side marker light.	12V 5W	Capless long life.
Fog lamp – Front.	12V 55W	Halogen H3 long life.
Fog light – Rear guard.	12V 21W	Bayonet long life.
Footwell light.	12V 5W	Bayonet long life.
Front direction indicator.	12V 21W	Bayonet amber long life.
Front parking (side) light.	12V 5W	Capless long life.
Glovebox light.	12V 4W	Bayonet long life.
Headlamp – dip.	12V 55W	Halogen H1 long life.
Headlamp – Main beam.	12V 60W	Halogen HB3.

Description	Capacity	Type
Luggage compartment light.	12V 5W	Festoon long life.
Number plate light.	12V 5W	Capless long life.
Rear direction indicator.	12V 21W	Bayonet amber long life.
Reverse light.	12V 21W	Bayonet long life.
Roof central courtesy light – Coupe.	12V 5W	Festoon long life.
Roof console map light.	12V 6W	Capless.
Side marker light	12V 5W	Capless long life
Stop/tail lights. (The stop lights in the inner positions are not used.)	12V 21/5W	Bayonet long life.
Sun visor vanity mirror light.	12V 3W	Festoon.

Windscreen Wiper Blades

Use Jaguar Screen Clean Paste to remove contamination from the windscreen to ensure effective wiping or if smearing or juddering becomes evident. A more aggressive cleaning agent may be required to remove stubborn contamination. Contact a Jaguar Dealer for advice.

Wash the wiper blades with a mild detergent solution.

Renew the wiper blades before and after each winter, or more often if required.

Note: The wiper blade rubber inserts will be renewed at every service interval except for the 40,000 mile (64 000 kilometre) interval when the wiper blades are renewed (chargeable to customer).

Windscreen Wiper Blades – Inspect, Clean and Renew

Lift the wiper blade clear of the windscreen and wipe the blade with a clean, soft cloth moistened with water to which a mild liquid detergent has been added.

Inspect the wiper blade, and if there any signs of wear or damage; renew the blade.

Renewing Windscreen Wiper Blades

Move the wiper arm away from the windscreen, squeeze the retaining clip and withdraw the wiper blade from the arm.

After fitting the new blade, check that it is held firmly.

Re-position the wiper arm and blade on the windscreen.

The wiper blades are specifically designed for Jaguar and no other type of blade will give the correct result.

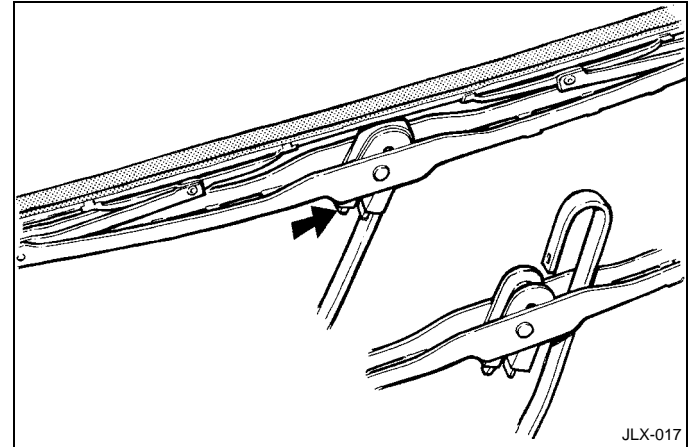

5-18 Vehicle maintenance

Windscreen Washers

The windscreen washer tubes and nozzles are mounted on the wiper arms to apply the washer fluid directly to the windscreen.

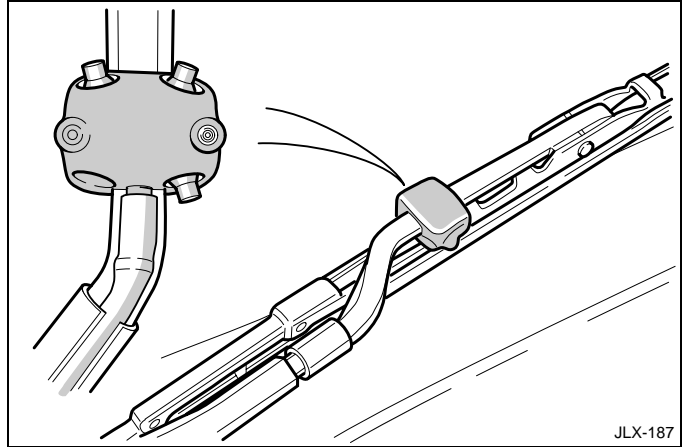

Powerwash System

Note: The headlamp washer jets are factory set. Should they require further adjustment consult your Jaguar Dealer.

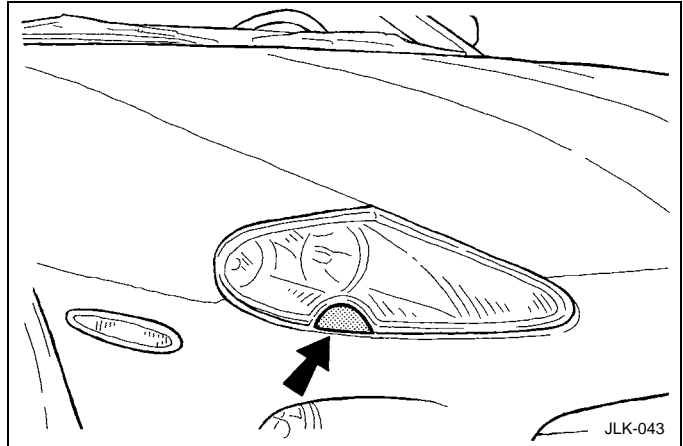

Vehicle Data

Engine	4.0 litre normally aspirated	4.0 litre supercharged
Type.....	V8, dual overhead camshafts 4 valves/cylinder.	V8, dual overhead camshafts 4 valves/cylinder.
Capacity.....	244 inch ³ (3996 cm ³)	244 inch ³ (3996 cm ³)
Bore.....	3.386 inch (86 mm)	3.386 inch (86 mm)
Stroke.....	3.386 inch (86 mm)	3.386 inch (86 mm)
Firing order: 1A and 1B cylinders at front of engine ..	1A, 1B, 4A, 2A, 2B, 3A, 3B, 4B	1A, 1B, 4A, 2A, 2B, 3A, 3B, 4B
Compression ratio.....	10.75 : 1	9.0 : 1
Spark plugs (unleaded fuel):		
– Type.....	NGK PFR5G-11E	NGK PFR5G-11E
– Electrode gap.....	0.040 – 0.043 inch (1.0 – 1.1 mm)	0.040 – 0.043 inch (1.0 – 1.1 mm)
 Transmission		
Type – Automatic.....	5 Speed	5 Speed
Final drive type.....	GKN 14HU On centre line differential	GKN 14HU On centre line differential

6-2 Specifications

Weights (Approximate)

Vehicles with the 4.0 litre normally aspirated engine

	Coupe		Convertible	
	kg	lb	kg	lb
Kerb weight	1615	3553	1705	3751
Front axle kerb weight	842	1852	877	1929
Rear axle kerb weight	773	1700	828	1821
Gross vehicle weight (G.V.W.)	2010	4431	2100	4630
Gross front axle weight	953	2100	983	2167
Gross rear axle weight	1057	2330	1117	2463
Maximum recommended luggage compartment load with passenger and driver	48	106	48	106

Note: Loads greater than 106lb (48kg) may be carried in the luggage compartment provided the maximum technically permissible axle weights shown on the vehicle Identification plate are not exceeded and the tyres are inflated to the 'normal pressures' given in the following table of recommended tyre pressures.

Weights (Approximate) (continued)

Vehicles with the 4.0 litre supercharged engine

	Coupe		Convertible	
	kg	lb	kg	lb
Kerb weight	1640	3616	1750	3858
Front axle kerb weight	853	1881	910	2006
Rear axle kerb weight	787	1735	840	1852
Gross vehicle weight (G.V.W.)	2010	4431	2100	4630
Gross front axle weight	953	2100	983	2167
Gross rear axle weight	1057	2330	1117	2463
Maximum recommended luggage compartment load with passenger and driver	48	106	48	106

Note: Loads greater than 106lb (48kg) may be carried in the luggage compartment provided the maximum technically permissible axle weights shown on the vehicle Identification plate are not exceeded and the tyres are inflated to the 'normal pressures' given in the following table of recommended tyre pressures.

6-4 Specifications

Dimensions (Coupe and Convertible)

	mm	inch
Overall length	4760	187.4
Overall width including mirrors	2016	81.7
Overall width without mirrors	1829	70.8
Overall height (at gross vehicle weight)	1271	
Minimum ground clearance (at gross vehicle weight):		
Coupe	164	6.5
Convertible	162	6.4
Wheelbase	2588	101.9
Track:		
Front	1504	59.2
Rear	1504	59.2
Turning circle:		
Kerb to kerb	11 metres	36 feet 1 inch

Wheel/Tyre Data

Jaguar original equipment and recommended wheels and tyres.

Caution: Do not mix tyre size or make.

Wheel name	Road wheel size	Tyre type/size
Revolver	8J x 17	Pirelli P Zero 245/50 ZR17 99Y Asimmetrico
Lamina	8J x 17	Pirelli P Zero 245/50 ZR17 99Y Asimmetrico
Impeller	Front 8J x 18 Rear 9J x 18	Front - Continental ContiSportContact 245/45 ZR 18 96W Rear - Continental ContiSportContact 255/45 ZR 18 99W
Double five	Front 8J x 18 Rear 9J x 18	Front - Continental ContiSportContact 245/45 ZR 18 96W Rear - Continental ContiSportContact 255/45 ZR 18 99W
Montreal	Front 9J x 20 Rear 10J x 20	Front - Pirelli P Zero 255/35 ZR 20 97Y J Direzionale Rear - Pirelli P Zero 285/30 ZR 20 99Y J Asimmetrico

6-6 Specifications

Temporary-use Spare Wheel (where fitted)

- Steel road wheel size. 3.5 x 18
- Alloy road wheel size. 4 x 18
- Tyre type/size. Pirelli 135/80 R 18



WARNING:

Failure to comply with the following can be dangerous. When a temporary-use spare wheel is fitted, switch off traction control, drive with caution and replace with the specified wheel and tyre assembly as soon as possible. Do not fit more than one temporary-use spare at one time. Temporary-use spare, maximum speed is 50 mph (80 km/h).

For information about the temporary use spare wheel, see page 4-1.

Winter (Snow) Tyres

The tyres fitted as original equipment are designed with a rubber compound, tread pattern and width specially suited for high speeds in normal road conditions, but they are less suitable during extremes of low temperatures, snow and ice. The use of winter tyres will considerably improve the vehicle's handling during these conditions.

Winter tyres must be used in vehicle sets of the same type/size, i.e. fitted on all four wheels.

It is recommended that only the following Jaguar approved winter tyres are used.

Tyre type/size:	Pirelli Winter 210 Performance M+S 245/50 R 17.
	Pirelli Winter 210 Performance M+S 245/45 R 18.

Caution: Tyre directional indicators must be rotating in a clockwise direction when viewed from the right-hand side of the vehicle, and anti-clockwise when viewed from the left-hand side of the vehicle.

Do not exceed 130 mph (210 km/h) when using Jaguar approved winter tyres.

For information about snow chains, or a 'Spikes Spider' accessory, see page 5-4.

Vehicles fitted with 'R' performance brakes: Special 18 inch winter wheels/tyres are available as an accessory for vehicles equipped with the 'R' performance brakes (the standard winter wheels will not fit). Tyre pressures for these winter wheels are as specified for 18 inch wheels in the following table.

If the vehicle is also fitted with the 'R' performance handling kit (modified suspension), the winter tyres must be inflated to the pressures specified for 20 inch wheels.

There is no 20 inch Jaguar approved winter tyre available.

Recommended Tyre Pressures

Tyres must be inflated to the following cold inflation pressures:

		Maximum comfort – Speeds up to 160 km/h (100 mph)	Normal Pressures
17 Inch Wheels	Front	26 lbf/in ² (180 kPa, 1,8 kg/cm ² , 1,8 bar)	32 lbf/in ² (220 kPa, 2,24 kg/cm ² , 2,2 bar)
	Rear	28 lbf/in ² (190 kPa, 2,0 kg/cm ² , 1,9 bar)	34 lbf/in ² (230 kPa, 2,4 kg/cm ² , 2,3 bar)
18 Inch Wheels	Front	26 lbf/in ² (180 kPa, 1,8 kg/cm ² , 1,8 bar)	32 lbf/in ² (220 kPa, 2,24 kg/cm ² , 2,2 bar)
	Rear	28 lbf/in ² (190 kPa, 2,0 kg/cm ² , 1,9 bar)	34 lbf/in ² (230 kPa, 2,4 kg/cm ² , 2,3 bar)
20 Inch Wheels	Front	32 lbf/in ² (220 kPa, 2,24 kg/cm ² , 2,2 bar)	32 lbf/in ² (220 kPa, 2,24 kg/cm ² , 2,2 bar)
	Rear	30 lbf/in ² (207 kPa, 2,1 kg/cm ² , 2,0 bar)	30 lbf/in ² (207 kPa, 2,1 kg/cm ² , 2,0 bar)
Temporary-use spare wheel		–	60 lbf/in ² (410 kPa, 4,2 kg/cm ² , 4,1 bar)

Note:

1. A label stating the recommended tyre pressures is fixed to the underside of the centre console storage compartment lid.
2. Certain alloy wheels have a valve cover on the wheel face. To access the valve, see Section 3: **Routine checks**.

Tyres without Jaguar approval

Any tyres other than those recommended should be inflated to 2 lbf/in² (14 kPa, 0,14 kg/cm², 0,14 bar) higher than the pressures identified above for the appropriate size (front and rear).

When using non-Jaguar approved winter tyres, increase inflation pressures by 2 lbf/in² (14 kPa, 0,14 kg/cm², 0,14 bar) higher than the pressures identified above for the appropriate size (front and rear) and do not exceed the tyre's speed capability.

6-8 Specifications

Fuel Requirements

Use only Premium Unleaded gasoline with a minimum Anti-Knock Index (AKI) of 91.

Oxygenated gasoline blended with ethanol (max. 10%) methanol (max. 10%) or methyl tertiary butyl ether (MTBE) (max. 15%) may be used.

Reformulated Gasoline with a minimum AKI of 91 may also be used.

The use of high quality fuel containing 'intake system deposit control' detergent and other additives will help to keep the vehicle's intake system free of deposits and its fuel system free of corrosion and gumming.

If high quality fuels containing 'intake system deposit control' detergent and other additives are used continuously, there should be no need to add any after market products to the fuel tank.

If problems are experienced with starting, rough idling or hesitation when the engine is cold, it may be caused by gasoline with a low volatility. Try a different grade and/or brand of fuel. If the condition persists, see a Jaguar Dealer or a qualified service technician.

Oxygenated Gasoline

Fuels that are blended with compounds containing oxygen, called oxygenates, may be used. Common oxygenates are ethanol or grain alcohol (blended at no more than 10%), methanol or wood alcohol (blended at no more than 5% with necessary co-solvents and additives, and MTBE or methyl tertiary butyl ether (blended at no more than 15%). The type of oxygenate may be found on the fuel pump or by asking the attendant. In certain areas of the country, oxygenates are required to be in all fuels to help improve air quality.

Generally, difficulty should not be experienced while operating the vehicle on fuels containing oxygenates. If problems are experienced switch to a fuel with a different type of oxygenate, or switch to a fuel that does not contain oxygenates, if available.

Reformulated Gasoline

Several petroleum companies have announced the availability of reformulated fuels.

These fuels are specially designed to further reduce vehicle emissions.

Jaguar fully supports all efforts to protect and maintain ambient air quality, and encourage the use of reformulated gasoline, where available.

Catalytic Converters

A few precautions on the use of vehicles fitted with catalytic converters are necessary. These are:

1. In order to maintain the efficiency of the emission control system it is essential that unleaded fuel is used. Use of leaded fuel will seriously damage the catalytic converters.
2. **Never** leave the vehicle unattended with the engine running.
3. Heavy impact on the converter casings must be avoided.
4. The engine settings must not be altered; they have been established to ensure that the vehicle will comply with stringent exhaust emission regulations. Incorrect engine settings could cause unusually high catalytic converter temperatures and thus result in damage to the converter and vehicle. If adjustment to the settings is considered necessary, this should be performed by a Jaguar Dealer.
5. A correctly tuned engine optimises exhaust emissions, performance and fuel economy and it is recommended that the vehicle is regularly maintained.
6. Do not continue to operate the vehicle if any engine malfunction is evident; malfunctions should be rectified immediately. For instance, misfire, loss of engine performance, excessive oil consumption or engine run-on may lead to unusually high catalytic converter temperatures and may result in damage to the converters and vehicle.
7. The use of catalytic converters increases exhaust system temperatures, therefore, do not operate or park the vehicle in areas where combustible materials such as dry grass or leaves may come into contact with the exhaust system.
8. Do not run the engine with either a spark plug lead disconnected or a spark plug removed. Do not use any device that requires an insert into a spark plug hole in order to generate air pressure e.g. tyre pump, paint spray attachment etc., as this could also result in catalytic converter damage.
9. The vehicle is designed for normal road use. Below are examples of abuse which could damage the catalytic converters and vehicle. These may lead to a dangerous condition due to excessively high catalytic converter temperatures.
 - Competition or off-road use.
 - Excessive engine speed.
 - Overloading the vehicle.
 - Switching off the engine whilst in gear.

6-10 Specifications

Electrical Accessories

The fitment of accessories, additional accessory supply sockets, relays and fuses must only be entrusted to a Jaguar Dealer.

Caution:

- 1. The use of any accessories not specifically designed for this Jaguar will damage the electrical circuits and systems of the vehicle.**
- 2. Under no circumstances must the power supply be obtained directly from either battery terminal.**
- 3. The use of non-approved accessories can reduce the battery capacity and charge period to an unacceptable level, therefore Jaguar cannot accept any liability for the fitment of any such item.**

The cigar lighter socket can be used for plug-in accessories which are only temporarily connected to the vehicle (e.g. car vacuum cleaner).

Electrical Accessory Supply Sockets

Two electrical accessory supply sockets are provided in the following areas:

1. On the passenger side, behind the glove box.
2. In the luggage compartment, clipped near the battery.

Note: Before connecting electrical accessories to these sockets, consult a Jaguar Dealer.

Earth Points

If an accessory needs to be connected to an earth point, consult a Jaguar Dealer.

Caution: Under no circumstances must holes be drilled in the bodywork to accept earth terminals.

7-2 Vehicle maintenance

Accessories	7-1	Capacities	3-9
Aerial – Cleaning	2-3	Care of the Exterior	2-1
Alternator	5-6	Care of the Interior	2-4
Anti-freeze	3-7	Carpets – Cleaning	2-4
Automatic Car Wash	2-1	Catalytic Converters	6-9
		Check/Top Up Windscreen Washer Reservoir	3-5
Battery	5-6	Cleaning	2-2
– Charging	5-7	– Carpets	2-4
– Connections – Clean and Grease	5-7	– Headlining	2-4
– Electrolyte – Check/Top Up	5-7	– Leather Upholstery	2-4
– Lead Connection	5-8	– Under Hood	2-2
– Lead Disconnection	5-8	Control Modules – Identification and Location	4-22
Battery/Ignition Isolator Switches	1-7	Convertible Top Fabric – Cleaning	2-2
Brake Fluid Reservoir – Check/Top Up	3-6	Coolant Level – Check/Top Up	3-4
Bulb Chart	5-16	Cooling System	3-7
Bulb Renewal	5-9		

Index

Data	6-1	Fire Extinguisher	4-26
Diagnostic System	1-1	Fuel Requirements	6-8
Dimensions	6-4	Fuel Tank – Capacity	3-9
Dipstick Location	3-3	Fuelling and Refuelling – Catalytic Converters	6-9
		Fuse Box	
Earth Points	7-1	– Engine Compartment	4-15
Electrical Accessories	7-1	– Luggage Compartment	4-16
Electrical Accessory Supply Sockets	7-1	Fuse Box Locations	4-14
Emergency Starting Using Jump Leads	4-8	Fuse Boxes – Fascia	4-16
Engine Block Heater	3-7	Fuse Ratings	4-17
Engine Oil		Fuses – Checking and Renewing	4-13
– Specification	3-8	Fuses and Fuse Boxes	4-13
– Used	1-7		
Engine Oil Level – Check/Top Up	3-4	Gasoline	
Exterior Care	2-1	– Oxygenated	6-8
		– Reformulated	6-8
		General Precautions	1-6
		Glass Surfaces – Cleaning	2-2
		Grease and Tar Removal	2-1

Hood Release Control	1-8	Paint Chips	2-3
Hydraulic Fluids	1-7	Polishing	2-3
Interior Care	2-4	Power Steering Reservoir – Check/Top Up	3-6
Jacking	4-6	Powerwash System	5-18
Jaguar Dealers	1-1	Precautions – General	1-6
Jaguar Diagnostic System	1-1	Regular Checks	3-1
Labels	1-5	– Daily	3-1
Leather Upholstery – Cleaning	2-4	– Monthly	3-1
Lubricants and Fluids – Recommended	3-8	– Weekly	3-1
Maintenance and Servicing	1-2	Regular Servicing	1-1
Modules – Control	4-22	Relay Identification and Location	4-23
		Reservoir Locations	3-3
		Routine Checks	3-1

Index

Safety Precautions	1-3
Safety, Warning and Caution Labels	1-5
Servicing – Regular	5-1
Snow (Winter) Tyres	6-6
Snow Chains	5-4
Spare Fuse Location	4-13
Spare Wheel and Jacking Equipment	4-1
Spare Wheel Stowage	4-2
Spark Plug Grades	6-1
Spikes Spiders	5-4
Steam Cleaning – Under Hood Area	2-2
Temporary-use Spare Wheel	4-1
Topping Up – Oil and Fluid Levels	3-4
Towing – Suspended Recovery	4-10
Towing Eyes	4-11
Transporting	4-10
Tyres	5-1
– Damage	5-2
– Data	6-5
– Pressures (Recommended)	6-7
– Renewal	5-2
– Repair	5-1
– Size and Type	5-2
– Use after Vehicle Storage	5-2
– Wear	5-3
– Winter (Snow)	6-6
Under Hood Cleaning	2-2
Valet Kit	2-1
Vehicle Data	6-1
Vehicle Recovery	4-10
Warning symbols	1-3
Washing	2-1
Weights	6-2
Wheel Changing and Jacking	4-2
Wheel/Tyre Data	6-5
Wheels	
– Care of	5-4
– Chromium-plated	2-3
– Cleaning	2-3
– Locking Nuts	4-4
– Temporary-use Spare	4-1
Windscreen Washer/Powerwash – Check/Top Up	3-5
Windscreen Washers	5-18
Windscreen Wiper Blades – Inspect, Clean and Renew ..	5-17

JJM 18 16 14/20