Audio Systems Handbook



Audio System Handbook

JAGUAR CARS LIMITED, as manufacturers, are dedicated to the design and production of vehicles which meet the expectations of the world's most discerning purchasers.

To complement the features, systems and technology of your new vehicle we have produced this Audio Systems Handbook. In it we have undertaken to make the control of complex systems easy to understand and operate.

The information contained herein applies to a range of vehicles and not to a specific vehicle. For the specification of a particular vehicle, owners should consult their Jaguar Dealer.

The Manufacturer reserves the right to vary its specifications with or without notice, and at such times and in such manner as it thinks fit. Major as well as minor changes may be involved in accordance with the Manufacturer's policy of constant product improvement.

All rights reserved. No part of this publication may be reproduced, stored in a retrieval system or transmitted, in any form, electronic, mechanical, photocopying, recording or other means without prior written permission from the Service Division of Jaguar Cars Limited.

Contents

1. Introduction and controls

General Information	1-1
Security code number (United Kingdom and Europe)	1-1
Radio cassette player controls	1-2
Steering wheel audio system Controls (where fitted)	1-3
Sound system display	1-3
Aerial operation	1-4
FM and AM reception	1-4
Optimising sound (premium systems only)	1-5

2. Sound system operation

Radio operation	2-1
Radio data system (RDS) and Traffic announcements (TA)	2-2
RDS and TA operation	2-3
RDS trouble-shooting guide	2-5
Radio set up modes	2-6
Cassette tape player operation	2-7
Compact disc (CD) player (where fitted)	2-10
CD operation	2-11
CD player fault diagnosis	2-13

3. In-car telephone

Telephone controls	3-1
Display messages	3-1
Hands-free phone system	3-2
In-car telephone controls	3-4
Receiving and making calls	3-6
Short message service (SMS)	3-9
Additional Information	3-10
Continuity of calls	3-10

4. System care

Care of the audio system	4-1
Cassettes	4-1
Compact Discs (CDs)	4-1
Aerial	4-1

General Information

The sound system is available in two versions: the Base System, and the Premium System.

The Base System comprises a radio, cassette tape player optional compact disc (CD) player and door mounted speakers.

The premium system has the CD player fitted as standard, extra speakers mounted in the doors and sub-woofers mounted in the parcel shelf (coupe) and rear quarters (convertible). Both systems have an FM aerial and an AM aerial telescopic rod aerial. An additional feature of the Premium System is digital signal processing (DSP) which enhances sound quality in two ways: sub-woofer control and optimising sound to occupant positions.

The system is operated by the controls on the fascia panel, and the controls on the left-hand side of the multi-function steering wheel (where fitted). The control panel has an alpha-numeric display which provides detailed information, including text messages, relating to the operation of the unit.

Security code number (United Kingdom and Europe)

This unit is protected by an anti-theft security code. If power to the radio drops to 5 volts or less, (dead battery), or there is a power interruption / disconnection, the radio display will indicate 'CODE' after a short delay. At this point the radio will not operate until you have re-entered the correct security code.

The four digit code for your radio is listed on the two radio security cards supplied with the vehicle. Enter the code by using the pre-set buttons 1 to 9 and a 'beep sound' occurs. If the code is not properly entered, then begin the code entry again, starting with the first digit. If the code is not properly entered after three successive attempts, the radio will not accept any entry until it has been left for one hour in the 'ON' position; the radio will accept three further entries.

Should you lose your radio security card, contact your Jaguar Dealer, who, for security reasons, will require proof of vehicle ownership.

1-2 Introduction and controls

Radio cassette player controls

Key

1. ON/OFF switch and volume control.
2. Mode button.
3. Cassette tape eject button.
4. Programme type (PT) and phone send and end button (United Kingdom and Europe).
5. Phone memory recall button.
6. Dolby B noise reduction (cassette mode) preset and phone key pad 1.
7. Programme change button (cassette mode) preset and phone key pad 4.
8. Preset buttons and phone key pad.
9. Radio tuning controls, cassette tape forward and rewind controls, CD player forward and reverse controls and seek function for all modes.
10. Auto memory (A-MEM) and phone key pad 0.
11. Traffic Information and Radio Data System (TA) and phone clear button (United Kingdom and Europe).
12. CD Mix (where fitted) and preset and phone key pad 7.

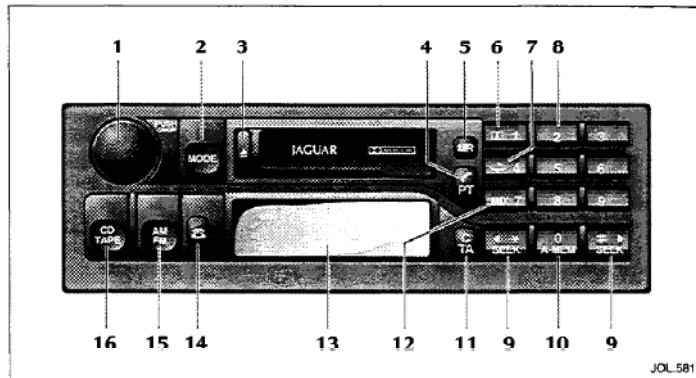

13. Display.
14. Phone mode button.
15. AM/FM band button
16. Cassette tape and CD player button (where fitted).

Steering wheel audio system Controls (where fitted)

Four audio system control buttons are situated on the left-hand side of the steering wheel. These buttons override the functions of the similar buttons on the radio control panel.

- A. Press to increase volume.
- B. Press to decrease volume.
- C. Press and release to cycle through Radio FM, AM, Cassette or CDs.
Press and hold to enter phone mode.
- D. Press and release to seek to next pre-set radio station, or to next track on tape and CD.
Press and hold to cycle to the next radio station, or to the next CD, or to change side of tape.

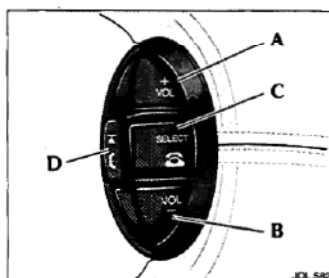

Sound system display

Example of radio display:

TA TP ST
FM 92.7 P2

- TP Traffic Programme (Europe, United Kingdom and USA).
- TA Traffic announcement selected
- ST Stereo.

1-4 Introduction and controls

Aerial operation

The aerial automatically rises when the radio is switched on and the ignition switch is in position I or II. The aerial will lower when the radio is switched off.

Note: The aerial will always be raised regardless of being in tape or CD modes, to enable RDS information to be received on the FM waveband.

Caution: Do not attempt to raise the aerial manually.

It is important to clean the radio aerial periodically to maintain smooth operation and good reception.

If your vehicle is fitted with a cellular telephone, you are advised to take the following precautions in areas where there is restricted overhead clearance such as an automatic car wash.

1. Switch the radio cassette and ignition OFF.

or

2. Switch the radio cassette and cellular telephone OFF.

FM and AM reception

FM reception has the advantages of low noise, minimal distortion, wide dynamic range, extended frequency response, and is usually broadcast in stereo. However, as FM frequency waves are relatively short and travel in a straight line, they can sometimes be impeded by obstructions, which may interrupt good reception in some parts of the country.

Whilst FM reception will generally provide better quality sound, AM reception or Medium Waveband (MW) and Long Waveband (LW) (United Kingdom and Europe) may be better in remote areas not covered by the shorter range FM transmitters.

When experiencing poor FM reception, background noise can be reduced by adjusting the Mode button into Treble adjustment position and reducing the treble setting.



ON/OFF and volume control

Press the knob to switch on the radio cassette and light up the display. Press the knob again to switch off. Turn the ON/OFF switch clockwise to increase volume and anti-clockwise to decrease volume.

Automatic volume control (AVC)

This is a feature which raises the volume of the radio to overcome road noise as the vehicle's speed increases. To switch AVC on or off, press the volume knob for more than two seconds. The current state will be displayed i.e. 'AVC ON'/'AVC OFF'. To toggle ON/OFF momentarily, press the volume control knob again to change the state. The 'AVC' level can be adjusted from 1 to 5 by turning the volume knob while in 'AVC ON' mode. After five seconds of no action, the radio will return to normal radio mode.

When AVC is ON, it is possible to override the automatic mode by adjusting the volume manually.



Mode button

Press the mode button repeatedly to cycle through the various modes. Once a function has been selected, turn the volume control to adjust sound quality. After about five seconds the radio will return to normal volume control mode.

The modes are:

- BASS Increase/decrease
- TREBLE Increase/decrease
- BALANCE Left to right
- FADE Front to rear
- NAV Set the relative levels of voice guidance volume to audio volume (voice guidance emphasis) - Only vehicles with Navigation Systems.
- SUB-WOOFER Set sub-woofer level from -7 to +7 (premium systems only).
- POS F-RIGHT* Set speaker delays to optimise stereo sound to different seating positions, see **Optimising sound.** (premium systems only).
*Screen display when optimising sound for 'front right' seating position.

Source tone memory - Bass and treble positions are automatically memorised for radio, cassette tape and CD allowing individual settings for each mode.

Optimising sound (premium systems only)

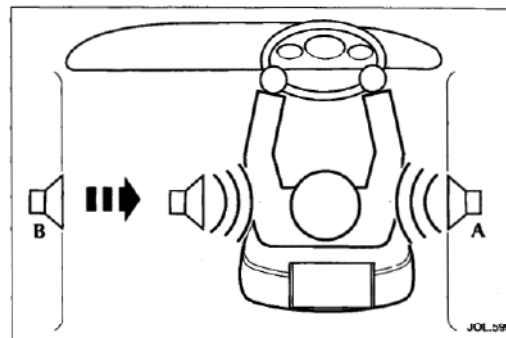

In the POSITIONS mode it is possible to introduce speaker delays to 'centralise' the stereo sound around a seating position. For example (see above) sound is optimised for the driver by introducing a delay in speaker (A), effectively moving speaker (B) to the position shown, balancing the stereo effect.

Sound can be optimised for:

- Front Left
- Front Right
- Centre (All)

To change the position setting:

Press the mode switch until 'POSITION' is displayed then turn the volume control to cycle through the available positions.

1-6 Introduction and controls

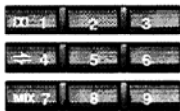

Preset buttons



WARNING:

Do not attempt to set the station presets while driving. Do this before starting a journey.

In each waveband, nine stations can be memorised in the bank of preset buttons marked 1 to 9. After tuning to a station, hold the chosen preset button for at least two seconds. The unit will 'beep' to indicate that the station has been stored. The station can be recalled from this preset memory by pressing the button momentarily, for less than two seconds. The steering wheel preset selection button when pressed will cycle through the nine preset stations (see page 1-3).



Seek and manual tuning

This control has two functions: seek and manual tuning. Momentarily pressing either button will activate the radio in the seek mode, making the tuner search up or down the frequency range for the next available station.

Push and hold either button to tune the radio manually, the display counts up or down to the frequency required. Incremental adjustment can be made by momentarily pressing the buttons until the required frequency is reached (After a short period this will return to seek tuning if you momentarily press the button).

Radio operation



Band Switch AM/FM

Band selection will be shown in the display panel. Pressing the band switch repeatedly will cycle the radio through FM, Medium and Long Wavebands (where applicable). When a cassette tape or CD is being played, pressing the Band Switch selects radio operation.



Auto memory (A-MEM)

The automatic memory function programmes the nine strongest stations on the selected waveband into presets 1 to 9.

To activate this function, hold the A-MEM button for at least two seconds.

The radio is muted briefly while it searches the waveband for the nine strongest stations. A beep indicates that programming is complete and preset number '1' is selected.

If stations cannot be found for all preset buttons, those found will be allocated to preset buttons, starting with number '1', leaving the remainder not programmed. The display will show 'NO FM' or 'NO AM' if unprogrammed buttons are selected.

To switch between the A-MEM preset stations and your own presets, press the button for less than two seconds.

A-MEM with radio data system (RDS) selected

(United Kingdom, Europe, USA and Canada)

If the A-MEM function is operated while in RDS mode, the radio will be muted briefly, while a search is made for the nine strongest RDS stations. Similarly, if A-MEM is used with Traffic

Announcement (TA) activated, the radio will only programme the nine strongest RDS stations carrying traffic information.

If stations cannot be found for all preset buttons, those which are found will be allocated to preset buttons, starting with number '1', leaving the remainder not programmed. The display will show 'NO FM' or 'NO AM' if unprogrammed buttons are selected.

Note: When used correctly, RDS and TP are very effective additional features in the radio's capabilities. However, if these facilities are used without full understanding, they may cause a situation confusing to the operator. This is less likely to occur as more RDS stations become available.

See page 2-2 for operating the radio's RDS and TA functions.

2-2 Sound system operation

Radio data system (RDS) and Traffic announcements (TA)

(United Kingdom, Europe, USA and Canada)

The Jaguar sound system is equipped with Radio Data Systems (RDS) which assists in finding and staying tuned to a chosen station. The radio decodes signals, transmitted with certain stations on FM, which provide the following functions (dependent upon service provided).

- **RDS station name display**
When RDS is selected the station name is displayed in eight characters as well as the frequency. The display also identifies network 'splits', where different programmes are being broadcast on FM, Medium Wave or Long Wave.
- **Automatic re-tuning to follow network stations**
RDS provides fully automatic radio tuning for network stations. It tunes to a signal not a frequency. The RDS will search out the strongest signal available for a given station and automatically switches frequency as necessary.
- **RDS Station/Programme type display and search**
RDS provides information as to the type of material broadcast by the station or programme that is on, i.e. News, Classical, Rock etc. Apart from being able to display this, the radio can search for one specific programme type that is selected.
- **RDS Priority programme type auto re-tuning**
(United Kingdom and Europe only)
Similar to Traffic Announcement this can be selected to interrupt and switch to the selected programme type, for its duration, i.e. 'NEWS'.
- **Local radio station's Traffic Information**
(United Kingdom and Europe only) -
RDS provides travel information relevant to the vehicle's location. As soon as the authorities learn of a traffic problem, they inform the nearest local radio station. The traffic announcement (TA) is then broadcast by the transmitters in the relevant area.
The TA will interrupt radio, cassette tape or CD play, on all equipment with the RDS feature, provided Traffic Announcement has been selected. If the volume control is set at minimum it will automatically increase to an audible level for the duration of the traffic new flash.
When the news flash is over, the system switches back to the driver's original listening choice and volume setting.

RDS and TA operation



To activate RDS: press the TA button and hold for at least two seconds

(Display: RDS ON)

To de-activate RDS: press the TA button again and hold.

(Display: RDS OFF)

When RDS is activated, the radio gathers RDS information and displays the Service name and frequency, provided the programme chosen is an RDS station.

If not, the radio will remain on station, the display will show the frequency and the 'RDS' will remain on in readiness for a signal.

When listening to a National Network Station, or a station that broadcasts on more than one frequency, the radio will re-tune to the strongest available signal. This 'network following' will continue throughout the journey. (The unselected presets will also receive new frequency information, if appropriate).

When RDS data is lost and no alternative frequency signal is available, the radio will stay on station, the display shows the frequency only and RDS remains on in

readiness for the signal to recover.

If the RDS function does not respond correctly, refer to the RDS Trouble-Shooting Guide on page 2-5.

Traffic announcements (TA) (United Kingdom and Europe only)

To activate TA: Press the TA button and hold for at least two seconds to activate RDS.

Then press TA momentarily (less than two seconds). A beep indicates TA activation.

To de-activate TA: Press the TA button momentarily. A beep indicates deactivation.

'TA' will be shown at the top of the display. The radio then checks that the station has RDS TP (Traffic Programme); Indicated by 'TP' at the top of the display. If the current station has no TP available, the display will show 'TP SEEK' while it searches for a station that does.

With TA activated, announcements, when transmitted will interrupt radio, tape or CD play. If set at minimum, the volume will be increased for the announcement, returning to normal setting afterwards.

When received, the display shows: 'TRAFFIC INFO'.

TA - preset minimum volume (United Kingdom and Europe only)

When the radio is set to minimum volume and a traffic announcement occurs, the volume is raised to a preset level. This level is adjustable by pressing and holding the 'MODE' button for more than two seconds. The volume level is adjusted between 1 (min) to 6 (max) by turning the volume control knob.

2-4 Sound system operation

RDS and TA Operation (Continued)



Programme type - PT

This has two functions:

To display current station programme type and to select a programme type and re-tune to it.

Momentarily press the 'PT' button to display the current station programme type. Use the tuning buttons to cycle through the available programme types, press the 'PT' button again to activate a search for the selected programme type. If there is a station with the correct PT, the radio will re-tune to it. If not, the radio will indicate 'NO PTY' and return to the current station.

Priority programme type (United Kingdom and Europe only)

Works in two ways as an interrupt, or as a 'PTY Following'.

Press and hold the 'PT' button to display the default priority programme type 'NEWS'. Use the tuning up and down buttons to cycle through the available programme types.

Press and hold the 'PT' button again to activate the selected priority programme type, 'PTY'. The radio will now wait for RDS information to indicate that a station has changed its programme type, i.e. to 'NEWS'. The radio will now re-tune to the new station for the duration that it remains on that programme type.

If the current station is already on the selected priority programme type, then when this station is lost, the radio will attempt to find another with the correct programme type.

To cancel priority programme type, press and hold the 'PT' button, the 'PTY' indicator on the display will be cleared.

TA and priority PTY interrupt skip (United Kingdom and Europe only)

Interruptions for Traffic Announcements, 'NEWS' or other selected priority PTY, can be skipped by pressing 'TA' or 'PT' during the interrupt. The radio returns to the previously selected station.

Note: Interrupt skip will not cancel the activation of this feature, and it will remain ready for the next interrupt.

Note: PTY and Priority PTY features are reliant upon the broadcast information from radio stations, and may be much better in some areas than others.



Phone mode

Pressing this button selects phone mode (where fitted).

RDS trouble-shooting guide

Incorrect response from RDS	Reason and rectification
Radio does not display programme name	Check that RDS is turned on by pressing the TA button and holding for more than two seconds. The display will confirm 'RDS ON' or 'RDS OFF' if radio does not display programme service name, it is not broadcasting RDS data, or you are in a poor reception area. Try re-tuning to another station with RDS.
Station name is lost and displays frequency only.	Radio has lost reception of the RDS data due to vehicle moving out of transmitter range, or loss of signal in a tunnel, under a garage forecourt canopy or some similar shielding. If the latter is the case, wait until the vehicle is clear of the shielding. There is a short delay before the station name returns.
Upon operating the A-MEM, most or all of the presets display 'NO FM' when pressed.	The radio cannot find nine FM, RDS FM or TP stations dependent upon the mode selected. If this occurs, switch off RDS or TA function and reselect A-MEM.
Upon pressing the TA button the radio re-tunes to another station and displays 'TP SEEK'.	The station selected does not have TP/TA facility, the radio will re-tune to one that does.
Radio sound goes off and the display shows 'PI SEEK'	The RDS radio station selected is unable to confirm that the frequency tuned to has the correct RDS data - programme identification (PI). It will then seek for a frequency that has the correct data.
Radio 'beeps' and the display shows 'NO TP/TA' and turns off 'TA'	The RDS TP radio station selected is unable to receive Traffic Programmes, due to the vehicle moving out of transmitter range, or loss of signal in a tunnel, under a garage forecourt canopy, or similar shielding. If required, re-tune the radio to another station or continue to listen to the station with RDS TA OFF.

2-6 Sound system operation

Radio set up modes

This function allows the radio to be set up to suit the user's operating preferences. By moving into 'Set Up' mode and using the Preset buttons, the owner or Jaguar Dealer can choose whether certain radio facilities are active or switched off.

When in 'Set Up' mode, pressing the relevant Preset button, as detailed below, will show on the display the facility that has been selected and its state. The selected facility can be changed to the user's preference by pressing the Preset button again.

To enter the set up mode: Press the 'Tape Eject' and the 'AM/FM' buttons simultaneously.

The display will show 'SET UP'. The following preferences can then be selected and changed, in any order, as long as no more than 15 seconds elapse between Presets. After 15 seconds the display will clear.

- Preset 1** Press Preset 1 to select the market mode, thereby enabling or disabling RDS, depending upon RDS availability in the user's country.
- Preset 2** This preset controls the 'Tape Clean' reminder facility. To switch off this reminder, press the Preset 2 button until 'TAPE CLN OFF' shows on the display.
- Preset 3** This preset controls the 'Aerial Clean' reminder facility. To switch off this reminder, press the Preset 3 button until 'AER CLN OFF' shows on the display.
- Preset 4** This preset controls the telephone 'Mute' facility. If a Jaguar telephone is installed, turn the telephone 'Mute' on by pressing the Preset 4 button until 'TEL ON' shows on the display.

- Preset 5** 'KEY OFF EJECT' - Sets the cassette tape to automatically eject when the ignition key is turned OFF.
- Preset 6** Blank
- Preset 7** 'DIVERSITY OFF' - Used when Diversity Aerial System is connected to the radio.
- Preset 8** 'AF ON/OFF' - Used when specific RDS problems occur, that may be helped.
- Preset 9** Blank.
- Preset 0** This preset is used to select one of the following regions: Europe, USA, Australia, Japan. Regional settings determine the correct frequency increments required for seeking stations, automatic tuning etc. Note that regions are preset at the factory.

Cassette tape player operation

At all times the display will indicate which function has been selected by using a simple word, figure or abbreviation - for example, SIDE 1 or SIDE 2, or Fast Forward etc.

Insert a cassette into the aperture and it will start to play immediately. After playing one side, it will auto-reverse and play the other side. If a Metal or Chrome, rather than a Ferric tape is used, the equalisation will be automatically adjusted.

Example of cassette tape play display

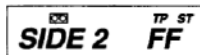

SEEK UP	Search to beginning of next track.
SEEK DOWN	Search to beginning of track being played.
REWIND	Rewind.
FAST FORWARD	Fast forward.
TAPE LOADING	Loading a tape into the mechanism.
TAPE EJECT	Ejecting a tape.
TAPE CLEAN	Tape mechanism requires cleaning.



Eject button and tape-in indicator
Press to eject the cassette.



Tape button

Pressing this button will play any cassette that is in the player. This function is also controlled by a button on the steering wheel (see page 1-3).



Band switches AM/FM

Pressing this button selects radio operation.



Dolby B

If you are using a cassette with a 'Dolby' recording, to select the noise reduction system, press the Dolby on/off button. An indicator is shown on the display.

Dolby noise reduction system is manufactured under license from Dolby Laboratories Licensing Corporation. 'Dolby' and the double-D symbol are trade-marks of Dolby Licensing Corporation.

2-8 Sound system operation

Cassette tape player operation (continued)



Programme change button

While playing a cassette, press this button to change to the other side of the tape. This function is also controlled by a button on the steering wheel - press and hold (see item 'C' on page 1-3).



Forward, rewind control

This control has two functions, seek to track and fast wind in each direction. Momentarily pressing the button will activate tape search to the beginning of the next track. The first press down will activate tape search to the beginning of the current track being played.

Pushing and holding either button for two seconds will activate continuous fast forward or rewind of the cassette. This can be cancelled by pressing the control in either direction.



Priority programme type (United Kingdom and Europe only)

Works in two ways: as an interrupt, or as a 'PTY Following'.

Press and hold the 'PT' button to display the default priority programme type, 'NEWS'. Use the tuning up and down button to cycle through the available programme types.

Press and hold the 'PT' button again to activate the selected priority programme type, 'PTY' will be shown in the display to indicate that it is active. The radio will now wait for RDS information to indicate that a station has changed its programme type, i.e. to 'NEWS'. The radio will interrupt the cassette tape for the duration that it remains on that programme type.

If the current station is already on the selected priority programme type, then when this station is lost, the radio will attempt to find another with the correct programme type.

To cancel priority programme type, press and hold the 'PT' button, the 'PTY' indicator on the display will be cleared.



Traffic announcements (TA) - local radio stations (United Kingdom and Europe only)

To select traffic announcement: Press the 'TA' button, a 'beep' will sound and 'TA' will be shown in the display. When there is a traffic announcement, the radio will interrupt the cassette tape and the display will show 'TRAFFIC INFO'.



CD Button

Pressing this button selects CD play (where fitted).



Phone Mode

Pressing this button selects phone mode (where fitted).

2-10 Sound system operation

Compact disc (CD) player (where fitted)

The radio cassette is used to control the CD autochanger. The CD unit comprises an autochanger which contains a magazine to take six discs, each mounted in a tray. This equipment is installed in the luggage compartment. The CD autochanger is available as an accessory from your Jaguar Dealer.

CD check sequence

When the CD Player is switched on it performs a check sequence. Each disc tray in the magazine is checked in turn and the display will show 'CHECK' and the tray number. When the six trays have been checked the player will return to disc one.

CD changer - loading and unloading discs and magazine

Ejecting the magazine

Slide the magazine door to the right (A). Press the eject button (B), the magazine will then partly eject from the changer.

Pull out the disc tray from the magazine (C) and load your six selected discs into each tray with the labels facing upwards (D), taking care not to touch the playing surface. Push the tray back into the magazine until it clicks.

Disc tray slots are numbered 1 (bottom slot) to 6 (top slot).

Inserting the magazine

Insert the loaded magazine into the changer (E) with the arrow mark facing upwards and pointing towards the CD changer. Ensure that it clicks into position. Close the sliding door.

Keep the sliding door closed to prevent dust entering the playing mechanism.

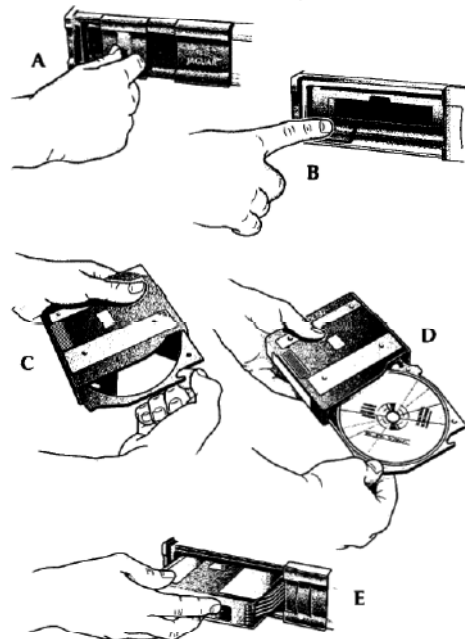

CD operation

The radio display shows which CD function has been selected.
Examples of CD Display, playing track 3 of CD1.

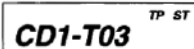

CD1-T03 TP ST

Other messages:

NO DISC - in the selected position.

NO MAGAZINE - in the CD Changer.

CD1 MIX 10 - the player is playing CD1 in MIX mode (track 10)

CD DMIX - all CDs are in MIX mode.

MAG EJECT - the magazine is being ejected.

DISC CHECK - the Autochanger is checking there is a disc.

PAUSE - the Autochanger is paused and ready to play.



CD button

This button can select CD from either tape or radio mode. This function is also controlled by the appropriate button on the steering wheel (see page 1-3).



Band switches AM and FM

Press this button to return to radio.



CD selection

Buttons 1 to 6 directly select the CD in those positions in the autochanger magazine. If there is no disc in the selected position, 'NO DISC' will be displayed. If there is no magazine in the changer, 'NO MAGAZINE' will be displayed.



MIX and disc MIX

Momentarily press this button to select MIX. The player plays the tracks of the selected disc in random order. To cancel, press MIX again or any other button.

Press and hold to select CD Mix. The player plays tracks from any disc in random order. To cancel press MIX again or any other button.

2-12 Sound system operation



Tape button

Pressing this button selects tape play, if a cassette is in the player.



Phone mode

Pressing this button selects phone mode (where fitted).



Forward, reverse control

This control has two functions: seek to track and fast play in each direction. Momentarily press the right-hand button to skip to the next track. Repeated pressing will select further tracks.

The left-hand button returns to the beginning of the current track. Repeated pressing selects previous tracks.

Pushing and holding either button selects continuous fast forward or fast reverse playing of the CD.

The sound level reduces during these cueing and reviewing modes. To cancel this mode, release the button.



Traffic announcement (TA) - local radio station (United Kingdom and Europe only)

To select traffic announcement: Press the 'TA' button momentarily; a 'beep' will sound and 'TA' will be shown in the display. When there is a traffic announcement the radio will interrupt the CD and the display will show 'TRAFFIC INFO'.



Priority programme type (United Kingdom and Europe only)

Works in two ways: as an interrupt, or as a 'PTY following'.

Press and hold the 'PT' button to display the default priority programme type 'NEWS'. Use the tuning up and down buttons to cycle through the available programme types.

Press and hold the 'PT' button again to activate the selected priority programme type. 'PTY' will be shown in the display to indicate that it is active. The radio will now wait for RDS information to indicate that a station has changed its programme type, i.e. to 'NEWS'. The radio will interrupt the CD player for the duration that it remains on that programme type.

If the current station is already on the selected priority programme type, then when this station is lost, the radio will attempt to find another with the correct programme type.

To cancel priority programme type, press and hold the 'PT' button, the 'PTY' indicator on the display will be cleared.

CD player fault diagnosis

If the CD Player does not operate properly, an error message will be displayed. The following table gives a fault diagnosis for each error message displayed.

MESSAGE	CAUSE	SOLUTION
E - 01	Disc-change malfunction.	See your Jaguar Dealer.
E - 02	Disc is in player mechanism.	Press the magazine eject button, insert an empty magazine into the player. Eject the magazine from the player by pressing the eject button. If the magazine fails to eject from the player, see your Jaguar Dealer.
E - 03 E - 04 E - 05	Disc-change malfunction.	If the error message goes out within a few seconds, the unit is working correctly. If the error message stays on, see your Jaguar Dealer.
E - 06	Disc-change malfunction.	Press the magazine eject button and pull out the magazine. Check that the error message goes out, then operate the function again. If the magazine cannot be pulled out, see your Jaguar Dealer.

2-14 Sound system operation

CD player fault diagnosis (continued)

MESSAGE	CAUSE	SOLUTION
E - 07	Magazine ejection impossible.	Press the magazine eject button. If the magazine does not eject, see your Jaguar Dealer.
E - 30	High temperature.	The error message will go out when the temperature returns to within the operating range.
NOT CONNECT	Bad connection or disconnected CD changer.	Check connection between CD changer and control unit. See your Jaguar Dealer.
NO MAGAZINE	No CD magazine in the changer.	Insert the CD magazine.
NO DISC	No CD in tray of magazine.	Insert a CD into the tray of the magazine.

In-car telephone 3-1

Telephone controls

1. ON/OFF switch and volume control.
2. Mode.
3. Phone send and end.
4. Phone memory recall.
5. Phone key pad - buttons 0 to 9.
6. Phone clear.
7. Display.
8. Phone mode.

Display messages

The following is a list of messages that may be displayed:

BLOCKED - SIM card is barred from use.

CALL - There is an incoming call.

CALLING - A call is being established.

CALL ENDED - Current call is terminated.

CARD - SIM card missing or incorrectly installed.

EMPTY - Memory location is empty.

HANDSET - This phone is in handset mode/rear handset operation only.

LOCATION? - Prompt for memory location number.

LOCATION# - Memory location number.

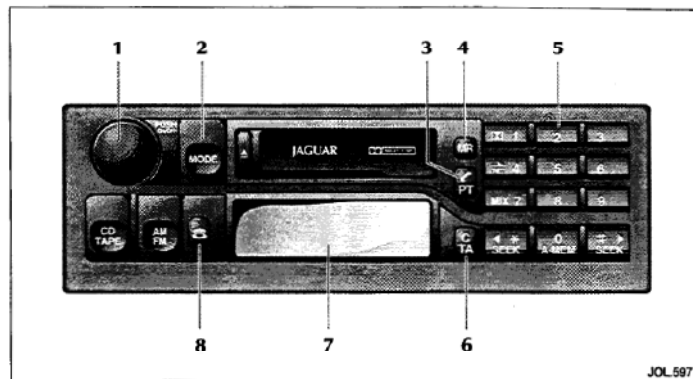

JOL597

LOCKED - The phone is locked - enter the unlock code on the phone keypad.

NO SVC - No cellular service available

PHONE - System is entering phone mode.

PIN - PIN required - enter the PIN on the sound system's keypad.

RESTRICT - Requested memory location or phone number restricted.

ROAM_____ - Phone connected to different network than 'home' system and an indication of signal strength.

SIG_____ - Indication of signal strength.

MESSAGE - A new Short Message Service note has been received.

NO MESSAGE - No new Short Message Service note has been received.

Note: Messages on the radio display may not be in the same language as the messages on the phone display. See Additional Information.

3-2 In-car telephone

Hands-free phone system

For hands-free operation the phone is connected to and installed in a cradle in the centre console storage compartment. The cradle interfaces with a directional microphone on the roof lining and the vehicle's sound system. The phone keypad and phone buttons on the radio, steering wheel switches, control the operation.

Audio system display

Phone related messages are shown on the audio system display when the phone system is active.

Speaker volume

The speaker volume can be adjusted independently for phone operation. To adjust, operate the ON/OFF volume control while the system is in phone mode.

If the sound system is on when the phone becomes active, the sound system source is suppressed for the duration of the call.

Conditions for hands-free operation

For hands-free operation:

- The phone must be connected to a GSM network, be unlocked, and have mute car radio set to ON.
- When you received your phone, your Jaguar Dealer will have checked that the phone is correctly set up for hands-free operation.
- The phone must be connected to and installed in the cradle.
- The radio / cassette / CD can be OFF or ON.
- The vehicle ignition switch must be in position 'I' (auxiliary) or 'II' (ignition).
- The system can only be used with Jaguar supplied and Approved StarTAC portable phones.

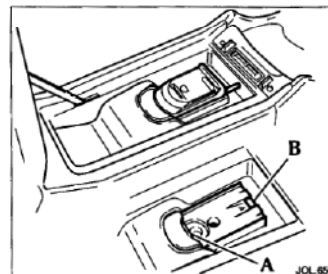

To remove / Install the Portable

To remove the portable from the cradle, slide the portable forwards to disconnect it from the base connector (A). Lift the base of the portable upwards and remove it from the cradle.

To install the portable in the cradle, retract the aerial, locate the top of the portable in the cradle and slide it forwards into the clip (B). Finally position the portable in the cradle by pushing it rearwards until it is engaged fully in the base connector (A).

Caution: Ensure that the portable is folded to the closed position before lowering the armrest.

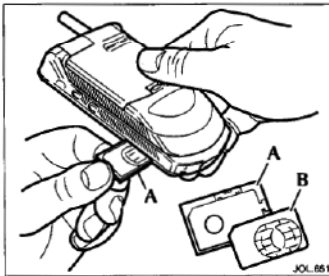

SIM card insertion and removal

The phone is supplied with a Subscriber Identity Module (SIM) card.

Removing the SIM card -

1. Turn the phone off from the power button on the portable.
2. Withdraw the SIM card holder (A) from the side of the portable.
3. Remove the SIM card from holder (B).

Insert the SIM card

1. Ensure that the phone is turned off.
2. Position the SIM card in its holder (B).
3. Insert the holder (A) into the slot.
4. Push the holder into place, so that it is flush with the side of the portable.

Electronic lock feature

For details of the electronic lock feature, see the telephone user guide.

Note: If the electronic lock feature has been selected, the unlock code will be lost whenever the engine is started (unless the safety timer has been enabled) thus making the phone inoperable until the code is entered again.

If the phone is locked, the portable display will show 'LOCKED' on entering phone mode. The sound system display will show 'LOCKED' for five seconds and then show 'CODE' before leaving phone mode and returning to the previous mode.

To unlock the phone, enter the unlock code on the portable keypad.

Operating with a PIN code

Note: If a PIN code number has been entered, it will be lost whenever the vehicle is started (unless the safety time has been enabled) thus making the phone inoperable until the code is entered again.

The PIN code can be entered through the radio's key pad. The display shows the word PIN. Entering the digits displays a series of '*' next to the word PIN. When the full code has been entered (minimum four digits) press the Send/end key to accept the PIN.

3-4 In-car telephone

In-car telephone controls

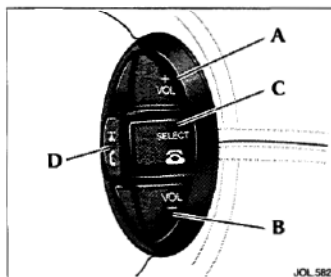

Steering wheel integrated phone buttons (where fitted)

Four control buttons are situated on the left-hand side of the steering wheel. These buttons override the functions of the similar buttons on the radio panel.

- A. Press to increase volume.
- B. Press to decrease volume.
- C. Press and hold to access phone mode.
- D. Press and release to scroll up to next memory location.
Press and hold to send and end a call.

Volume control and fader mode

The phone volume can be adjusted from the radio volume control or the steering wheel switches. The volume set is memorised for the next time phone mode is entered (this will not adjust the other audio volume settings).

To adjust: With the system in phone mode, press the mode button repeatedly until FADE is displayed. Use the ON/OFF volume control to set the fade.

SELECT (steering wheel switch - item 'C') - Press and hold to enter phone mode.

Momentarily press to exit phone mode and return to the previous audio mode (when a call has ended).



Phone mode button

This button will activate the phone mode, ready to make a call and the display will indicate that phone mode has been selected.

This function can also be controlled from the steering wheel (press and hold 'C' on steering wheel switch).



Key pad

Enter the required telephone number, each key press will beep and the digit is displayed on the radio.

Also used in 'Memory Recall', to enter a location number, or to scroll up/down the memory locations.



Clear

Momentarily press this button to clear the last digit from the entered telephone number.

Press and hold this button to clear all of the digits entered.



Send and end

Press this button to send the entered telephone number. Also used to end a call that is in progress.

This function can also be controlled from the steering wheel, (press and hold 'D' on page 3 - 4).



CD / Tape button

Press this button (when a call has ended) to cycle through CD, Tape or inserting a tape functions.



Memory recall

Press to access the phone memory and recall a number. Either a memory location number can be entered from the key pad, or memory locations can be scrolled up and down from the key pad scroll keys.

This function can also be controlled from the steering wheel, (momentarily press 'D' on page 3 - 4).



Band switches AM and FM

Pressing this button selects radio operation (when a call has ended).





3-6 In-car telephone

Receiving and making calls

Receiving

An incoming call automatically switches the sound system into the phone mode. The radio display will show **CALL** and ringing is heard through the sound system.

If automatic answer has been programmed the call will automatically answer after two rings.

1. **To answer:** press and hold the  switch on the steering wheel or press  on the radio.
The display shows **SIG** or **ROAM**.
2. **To end:** press and hold the  switch on the steering wheel or press  on the radio.
3. **To exit:** once the call has ended the radio will automatically leave phone mode after six seconds.
If the radio, cassette or CD was OFF, the system will return to OFF.







Receiving a call with 'Call Line Ident'

If the caller has the 'Call Line Identity' (CLI) feature, **CALL** is shown on the radio display followed by the caller's phone number. In addition, if you have previously stored the caller's name and phone number in your phone's memory, after the word **CALL**, the caller's name will be shown for two seconds. When the two seconds have elapsed, the phone number will be displayed until the call is answered.

Making a call





When making a call, there are four methods of dialling: Keypad, Turbo, memory search and last number redial.

Keypad dialling

1. **To dial:** press and hold the  switch on the steering wheel or press  on the radio.
PHONE is displayed for two seconds followed by **SIG** or **ROAM**.
2. Key in the phone number on the radio keypad. The number is displayed.
3. **To connect:** press and hold the  switch on the steering wheel or press  on the radio.
The display shows **CALLING**.
When the call is connected the display shows **SIG** or **ROAM**.
4. **To end:** press and hold the  switch on the steering wheel or press  on the radio.
5. **To exit:** press the  switch on the steering wheel or press a source button, AM-FM, Tape or CD.
If the radio, cassette or CD was OFF, the system will return to OFF.









Turbo dialling

Note: Turbo dialling is only available from the phone's memory (1-9) not the SIM card memory

1. **To dial:** press and hold the  switch on the steering wheel or press  on the radio.
PHONE is displayed for two seconds followed by SIG or ROAM.
2. On the radio keypad, press and hold the required turbo dialling memory location number 1 to 9.
After three seconds CALLING is displayed.
3. **To end:** press and hold the  switch on the steering wheel or press  on the radio.
4. **To exit:** press the  switch on the steering wheel or press a source button, AM-FM, Tape or CD.
If the radio, cassette or CD was OFF, the system will return to OFF.

Memory recall dialling

(Radio buttons only)









1. **To dial:** Press and hold the  switch on the steering wheel or press  on the radio.
PHONE is displayed for two seconds followed by SIG or ROAM.
2. Press the  button.
LOCATION? is displayed.
3. On the radio keypad, press the required memory number 1 to 255 (depending on SIM card) or:
Press the  button (for memory recall location 1) or the  button (for the highest stored location number), then repeatedly press either button to scroll through until you reach the location number you require.
Note: You can key in any number between 1 and 255 then use the arrow keys to scroll up and down.
The memory location number is displayed followed by the location name and then the location phone number.
4. **To connect:** press and hold the  switch on the steering wheel or press the  switch on the radio.
CALLING is displayed followed by SIG or ROAM when the call is connected.
5. **To end:** press and hold the  switch on the steering wheel or press  on the radio.
6. **To exit:** press a source button, AM-FM, Tape or CD.
If the radio, cassette or CD was OFF, the system will return to OFF.

3-8 In-car telephone

Memory recall dialing







(Steering wheel switches only)

Note: You **cannot** combine memory recall from the radio by pressing the **MR** button and using with steering wheel controls

1. **To dial:** Press and hold the  switch.
PHONE is displayed for two seconds followed by **SIG** or **ROAM**.
2. Press the  switch.
The display shows the lowest occupied location name followed by the number.
3. If you require a higher location number, repeatedly press the  switch until you get the required number.
The display shows the next occupied location number each time the switch is pressed.
Shortly after the last press, the display shows the location name followed by the number.
4. **To connect:** press and hold the  switch on the steering wheel or press the  switch on the radio.
CALLING is displayed followed by **SIG** or **ROAM** when the call is connected.
5. **To end:** press and hold the  switch on the steering wheel or press  on the radio.
6. **To exit:** press the  switch on the steering wheel or press a source button, AM-FM, Tape or CD.
If the radio, cassette or CD was OFF, the system will return to OFF.

Last number redial

Note: Last number redial recalls the phone number of the last hands-free call made since the ignition was switched on. When the ignition is switched off, the last number called is lost from the system's memory. The last call made on the handset cannot be recalled during hands-free operation.

1. **To dial:** press and hold the  switch on the steering wheel or press  on the radio.
PHONE is displayed for two seconds followed by **SIG** or **ROAM**.
2. On the radio press the **MR** button twice. The display shows the last number called.
Note: If the last number was dialed using keypad dialing, you can change the number by pressing the clear button. If the last number was dialed using memory recall dialing, you can only scroll through the memory recall numbers, but not change them.
3. **To connect:** press and hold the  switch on the steering wheel or press the  switch on the radio.
CALLING is displayed followed by **SIG** or **ROAM** when the call is connected.
4. **To end:** press and hold the  switch on the steering wheel or press  on the radio.
5. **To exit:** press the  switch on the steering wheel or press a source button, AM-FM, Tape or CD.
If the radio, cassette or CD was OFF, the system will return to OFF.

Short message service (SMS)

If an incoming message is received 'MESSAGE' is displayed on the screen. To access the message press **MR** and **0** on the radio.

The message number will be displayed followed by the text of the message.

Multiple messages can be scrolled through using the **◀ ▶** buttons.

Messages can only be read, they cannot be sent.

3-10 In-car telephone

Additional Information

Handset Mode

The handset mode is when the phone is removed from the cradle and used as a portable. Calls can be made or received in the handset mode using the keypad and control button on the phone. The radio sound system will return to its previous mode once the portable is removed from the cradle.

Continuity of calls

With a call in progress in hands-free mode, the call remains connected if the vehicle's ignition switch is turned to position 'O' (OFF). When the call ends, another call cannot be made or received unless the ignition switch is turned to position 'I' (auxiliary) or 'II' (ignition).

Should you be using the phone as a portable when a call is in progress and wish to plug the phone into the cradle for hands-free operation, first ensure that the ignition switch is turned to position 'I' or 'II'. Install the portable into the cradle with its flip cover remaining in the open position. The radio sound system will switch to phone mode and the call timer will continue from when you began the call. If you wish to close the flip cover, first press the '↑' followed by '6', otherwise the call will be terminated.

Caution: Before lowering the armrest ensure that the portable is folded into the closed position.

Battery charging

While the phone is connected to and installed in the cradle, the phone's battery is automatically charged whenever the ignition is ON.

DTMF Tones

While in a call you can transmit a DTMF (Dual Tone Multi Frequency) tone, to control remotely equipment such as an answering machine, by keying in the appropriate numbers on the radio keypad. The numbers entered will show on the radio display until the call ends. This feature can be keyed by using either the radio keypad or the phone keypad.

Changing a Phone Number

When making a call, you can change the phone number shown on the radio display using the C button on the radio.

A momentary press erases any single digit; a long press erases the complete number.

Care of the audio system

Do not use petrol, solvents or abrasive cleaners on the radio. Wipe the surface of the radio with a lint-free cloth to remove dust. Slightly moisten the cloth with clean water to remove any finger marks from the outside surface of the radio.

Cassettes

Always use good quality cassettes. Low cost tapes can cause jamming, the sound quality will be inferior, and they can create a fast build-up of deposits on the play-back head.

Before playing, check the cassettes to ensure that the tape is not loose on the spools. If necessary, take up the slack by gently turning the spools with the end of a pencil. A jammed or sticking tape will cause the auto-reverse mechanism to operate continuously.

It is best not to use a tape longer than 45 minutes playing time each side (C90). Cassettes should be stored in their library cases away from direct sunlight. Do not store cassettes in door pockets where they could be affected by the magnets in loud-speakers which might impair the sound quality.

Never insert a cassette that has a torn or loose label, it may cause the mechanism to jam.

After approximately 15 hours playing time, the display on the radio will show 'CLEAN TAPE'. Clean the tape mechanism itself using a mechanical type cleaner with a wetting agent in an approved kit available from your Jaguar Dealer. Do not use abrasive type cleaners as they can cause excessive wear on the play-back head.

Compact Discs (CDs)

When handling CDs, do not touch the playing surface. When they are not being used they should always be stored in their cases away from direct sunlight, heat and dust. Scratches, finger-marks or dust on the surface of a disc can cause the optical pick-up to skip tracks. If the surface is dirty, use an appropriate CD cleaner.

Do not attempt to play damaged, warped, cracked or oversized discs. They could seriously damage the play-back mechanism.

Aerial

The aerial care procedure should be carried out when cleaning the exterior of the vehicle, to ensure smooth and reliable operation of the aerial.

When cleaning the aerial, always wipe it in an upwards direction. Occasionally use an aerial maintenance wipe cloth to lubricate the aerial.

In freezing conditions check that no ice has formed over the top of the aerial, this could prevent it from being raised, causing damage to the lift motor.

A special aerial cleaner is available from your Jaguar Dealer.

4-2 System care



Index

Aerial operation	1-4	CD player fault diagnosis	2-13
Care of the audio system	4-1	Compact disc (CD) player	2-10
– Aerial	4-1	– CD check sequence	2-10
– Cassettes	4-1	FM and AM reception	1-4
– Compact discs (CDs)	4-1	General Information	1-1
Cassette tape operation	2-7	In-car telephone	3-10
– Band switches AM/FM	2-7	– Additional Information	3-9
– CD Button	2-9	– Short message service (SMS)	3-6
– Dolby B	2-7	In-car telephone - making calls	3-6
– Eject button and tape-in indicator	2-7	– Last number redial	3-8
– Forward, rewind control	2-8	– Making a call	3-6
– Phone mode	2-9	– Memory recall dialling (radio buttons)	3-7
– Priority programme type	2-8	– Memory recall dialling (steering wheel)	3-8
– Programme change button	2-8	– Receiving	3-6
– Tape button	2-7	– Turbo dialling	3-7
– Traffic announcements - local radio stations	2-9	In-car telephone controls	3-1, 3-4
CD changer	2-10	– Band switches AM and FM	3-5
– Ejecting the magazine	2-10	– CD button	3-5
– Inserting the magazine	2-10	– Clear	3-5
CD operation	2-11	– Display messages	3-1
– Band switches AM and FM	2-11	– Memory recall	3-5
– CD button	2-11	– Phone mode button	3-4
– CD selection	2-11	– Send and end	3-5
– Forward, reverse control	2-12	– Steering wheel integrated phone buttons	3-4
– MIX and disc MIX	2-11	– Volume control and fader mode	3-4
– Phone mode	2-12		
– Priority programme type	2-12		
– Tape button	2-12		
– Traffic announcement - local radio station	2-12		

Index

In-car telephone hands-free phone system	3-2	Radio set up modes	2-6
– Audio system display	3-2	– To enter the set up mode	2-6
– Conditions for hands-free operation	3-2	Receiving and making calls	
– electronic lock	3-3	– Receiving a call with 'Call Line Ident'	3-6
– Operating with a PIN code	3-3	Security code number	1-1
– SIM card insertion and removal	3-3	Sound quality	
– Speaker volume	3-2	– Mode button	1-5
– To remove / install the portable	3-2	– Optimising sound	1-5
In-car telephone operation		– Source tone memory	1-5
– Key pad	3-4	Sound system display	1-3
– SELECT (steering wheel switch - item 'C')	3-4	Steering wheel audio system controls	1-3
Radio cassette	1-2	Tuning control	
Radio data system and traffic announcements	2-2	– Preset buttons	1-6
– Priority programme type	2-4	– Seek and manual tuning	1-6
– Programme type - PT	2-4	Volume control	
– RDS and TA operation	2-3	– automatic	1-4
– RDS trouble-shooting guide	2-5	– ON/OFF	1-4
– TA and priority PTY interrupt skip	2-4		
– TA preset minimum volume	2-3		
– Traffic announcements	2-3		
Radio operation	2-1		
– A-MEM with RDS selected	2-1		
– Auto memory (A-MEM)	2-1		
– Band switch AM/FM	2-1		
– Phone mode	2-4		