

A/T - Squawk/Chirp Noise On Shifts

NUMBER: JTB00070

VERSION 1

MODEL: S-TYPE, XJ, XK

DATE: DECEMBER 5, 2007

THIS BULLETIN, ALONG WITH JTB00071, REPLACES JTB00040 VERSION 2, DATED 31 JULY 2007.

SECTION: 307-01

Transmission Noise During Gear Shifts - Repair Procedure

<b>S-TYPE (X200)</b>	<b>VIN:</b>	<b>M45255 to N52047</b>
	<b>Model Year:</b>	<b>2003 - 2005</b>
<b>XJ (X350)</b>	<b>VIN:</b>	<b>G00442 to G49700</b>
	<b>Model Year:</b>	<b>2004 - 2005</b>
<b>XK8 (X100)</b>	<b>VIN:</b>	<b>A30645 to A48684</b>
	<b>Model Year:</b>	<b>2003 - 2005</b>

AFFECTED VEHICLE RANGE

CONDITION SUMMARY:

SQUAWK/CHIRP NOISE DURING TRANSMISSION GEAR SHIFTS

Situation:

The customer may complain of a squawk noise from the automatic transmission when changing into third gear. The noise may also occur on kick-down from fourth to third and sixth to third gears. A squawk or chirp noise can also be heard when changing from third to fourth gear at 50% throttle. The likely cause is that the 'E' [clutch](#) sticks and releases when engaging and disengaging gear.

Action:

Should a customer express concern about noise during gear shifts, follow the Repair Procedure below to remedy it using the additive.

**C2C 37157    TRANSMISSION FLUID ADDITIVE    QTY 1** \_

## PARTS

**NOTE:** The additive must only be used in the following cases:

- ^ To fix a transmission noise during gearshifts (squawk).
- ^ It must only be used once in a transmission. The exception to the "use once" rule is if the transmission has had a complete fluid change, where a second application may be used on a customer complaint of transmission squawk.

**NOTE:** The additive must not be used in the following circumstances:

- ^ It must not be used in an attempt to fix any other transmission concerns, for example noises other than squawk, harsh transmission shifts, or Diagnostic Trouble Codes (DTC) logged in the transmission control module.
- ^ The additive must not be used on any cars from 2006 MY onwards starting with VINS S-TYPE: N52048, XJ Range: H00332, New XK: ALL vehicles.
- ^ The additive must not be used more than once in a transmission apart from the exception described in the second bullet of the NOTE above.
- ^ Do not use the additive as a preventative measure. It must not be used unless there is transmission noise during gearshifts (squawk) present.
- ^ Do not add the fluid during initial oil fill when a new or remanufactured transmission is installed.
- ^ The effects of using the additive incorrectly as outlined above may be reduced friction of the clutches leading to poor shift quality, logged DTCs, and it can also induce flare.

<i>Description</i>	<i>SRO</i>	<i>Time (Hours)</i>	<i>Condition Code</i>	<i>Causal Part</i>
Transmission noise service procedure - XJ	44.91.35	0.9	42	C2C 37157
Transmission noise service procedure – S-TYPE, XK	44.91.35	1.0		

*Normal warranty policy and procedures apply.*

## WARRANTY

**NOTE:** Repair procedures are under constant review, and therefore times are subject to change; those quoted here must be taken as guidance only. Always refer to DDW to obtain the latest repair time.

DDW requires the use of causal part numbers. Labor only claims must show the causal part number with a quantity of zero.

## REPAIR PROCEDURE

### TRANSMISSION NOISE SERVICE

**CAUTION:** If the service fix label is already attached to the transmission oil pan, the Repair Procedure in this bulletin should NOT be carried out. Performing the procedure a second time can cause severe damage to the transmission.

1. Raise vehicle on a four-post ramp.

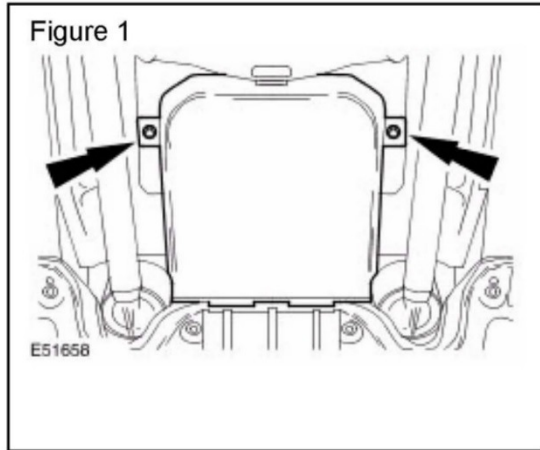

2. If an S-TYPE vehicle is being repaired, remove the engine undertray. (Figure 1)

3. Place clean drain container under the transmission.

**CAUTION:** The transmission must be cold before removing the fluid drain plug. The drain plug must not be fully removed as only one liter of fluid is to be collected.

**NOTE:** Illustrations show XJ Range. S-TYPE and XK are similar.

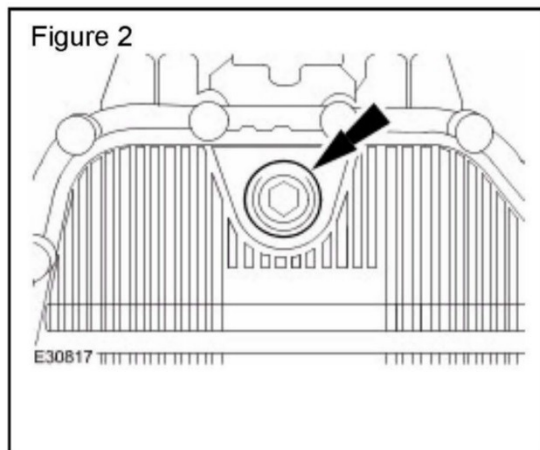

4. Undo and partially remove the transmission fluid drain plug. (Figure 2)
5. Collect one liter (33.8 oz) of fluid from the transmission into a clean measuring jug.
6. Reinstall and tighten the transmission fluid drain plug to 8 Nm (5.9 lbf-ft).
7. Ensure the selector lever is in 'P' and the handbrake is applied.
8. Start the engine and allow to idle.
9. Unscrew transmission filler plug and fill with one liter of the additive (C2C 37157) using a clean syringe.
10. Install filler plug.

11. Pull the service fix label off the bottle and apply it to the transmission oil pan near the filler plug. (Figure 3)
12. If an S-TYPE vehicle is being repaired, install the engine undertray. (Figure 1)

**NOTE:**

Global Technical Reference (GTR) lookup sequence is as follows:

GTR Home> NAS > (select vehicle and year) / Service Information > Workshop Manuals>  
Bookmarks Powertrain/[Automatic Transmission/Transaxle](#)/307-01 Automatic  
Transmission/Transaxle "LINK Fluid Level Check"

13. Refer to GTR Workshop Manual, section: 307-01 and check / top-up the transmission fluid level.