

## Transmission Range (TR) Sensor

### Removal

1. Open the driver's door, or both doors if necessary, to allow the side glass to drop. Ensure that the doors remain open until after the battery has been disconnected.

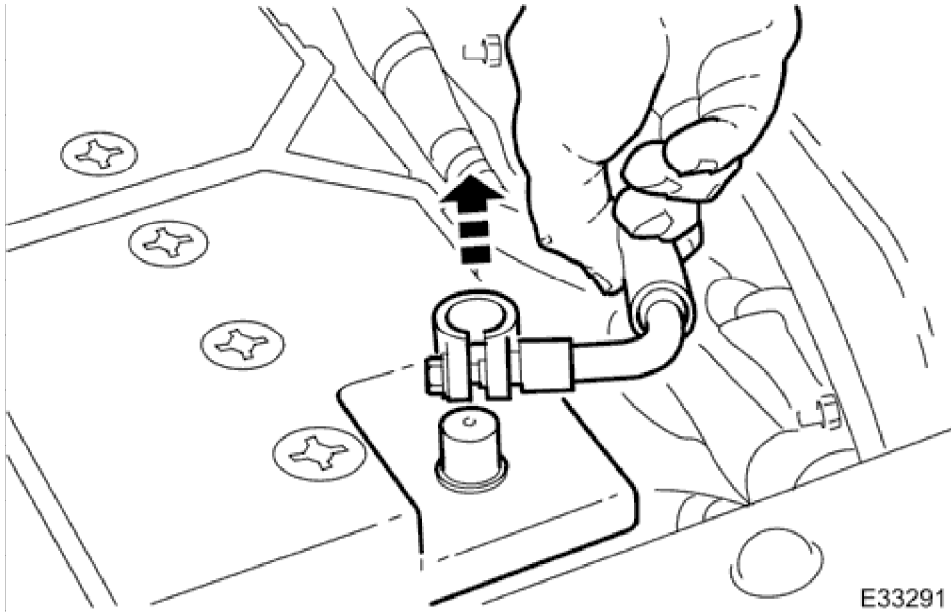

2. Disconnect battery ground cable.
  - Remove the battery cover.

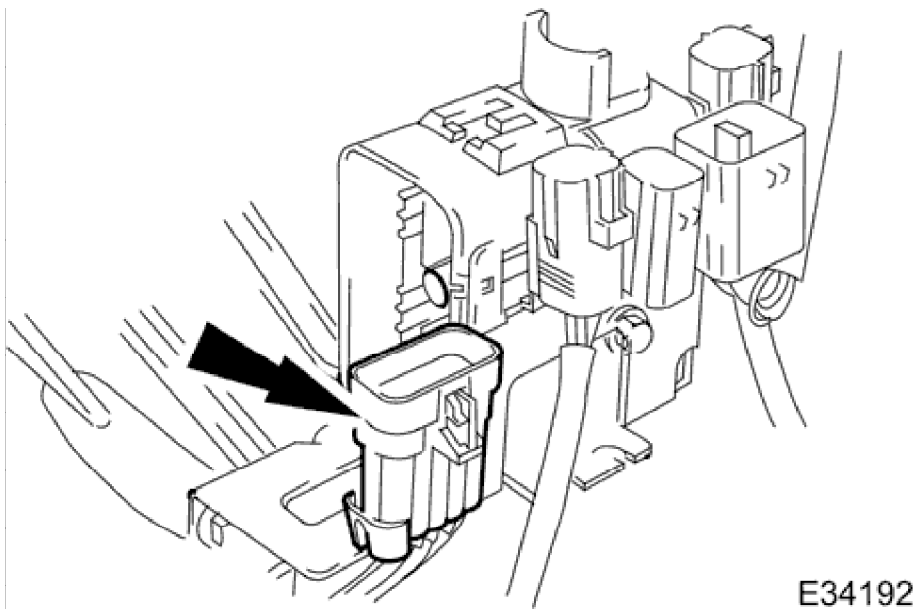

3. From above, disconnect the rotary switch harness multiplug.

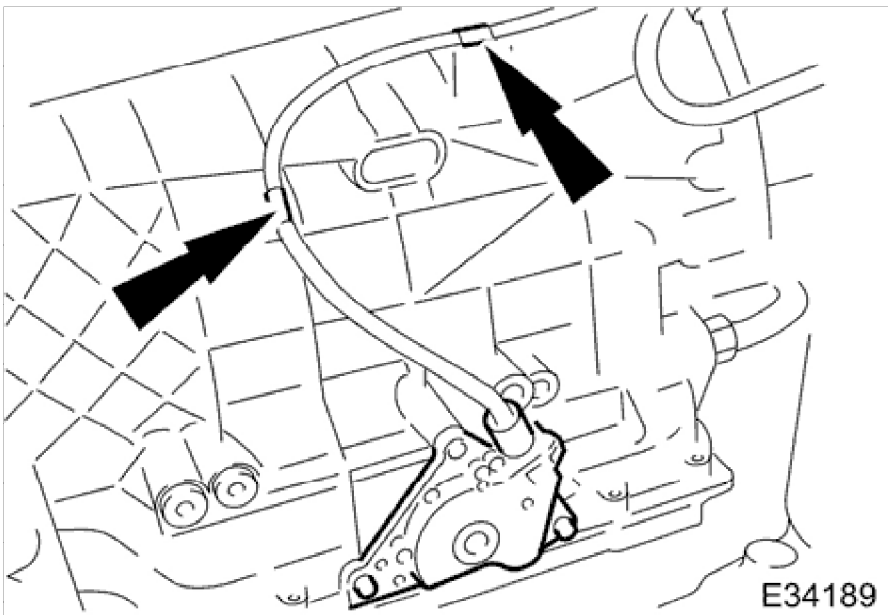

4. From below, release the harness from the retaining clips.

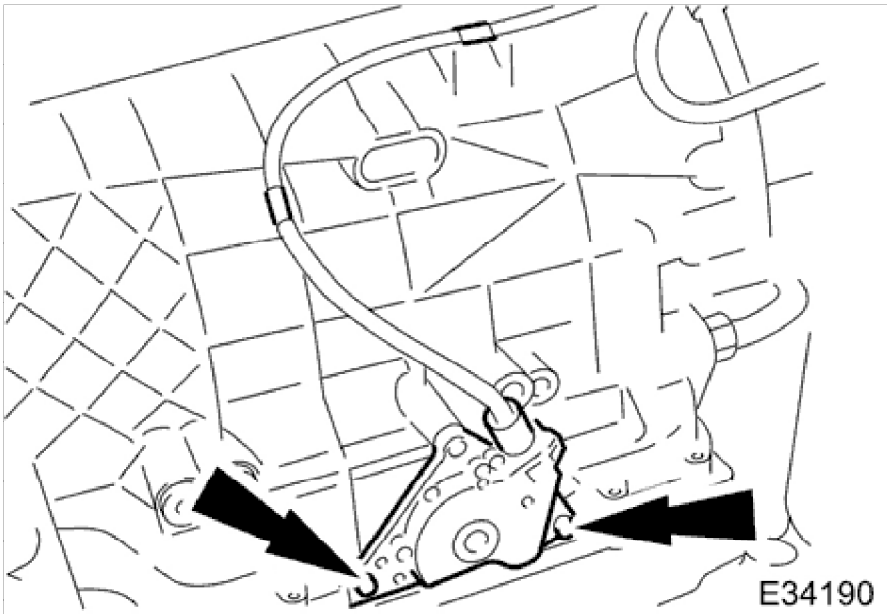

5. Remove the rotary switch retaining fixings.

**Installation**

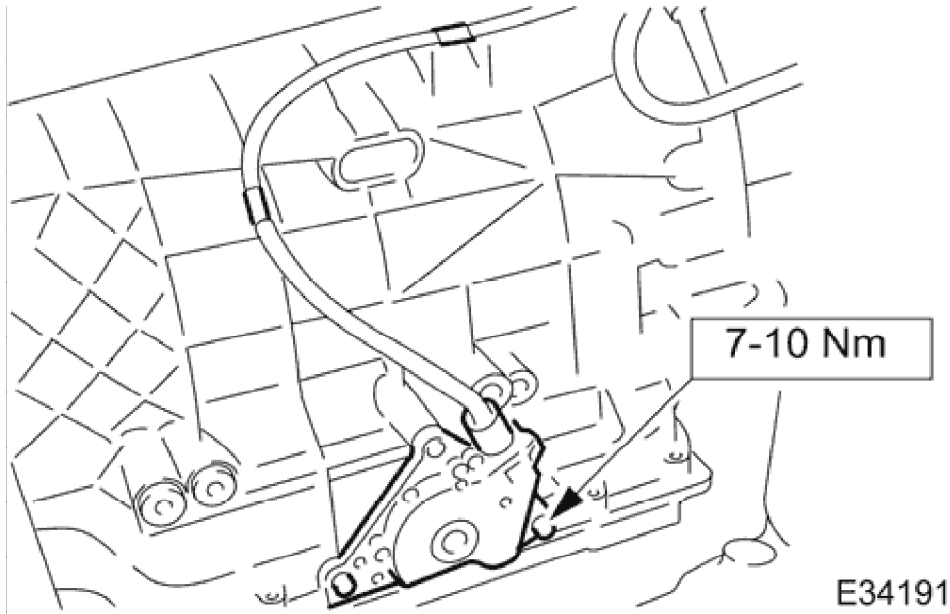

1. Fitting a new rotary switch is the reverse of the removal procedure noting that the fixings must be tightened to the specified torque figure.
2. Perform the Battery Reconnection Procedure described in Operation <<86.15.15>>.