

Shock Absorber and Spring Assembly 60.30.02

Removal

-  **CAUTION:**
Replacement of nuts and bolts: Various thread-locking devices are used on nuts and bolts throughout the vehicle. These devices restrict the number of times a nut or bolt can be used. See section <<100-00>> for information.

Open engine compartment and fit paintwork protection covers to fenders.

- Raise front of vehicle and support on stands. Refer to section <<100-02>>.

- Remove front wheel. Refer to section <<204-04>>.

-  **CAUTION:**
The suspension must remain supported by the jack throughout this operation, to prevent damage to the upper and lower ball-joints.

Place a jack under the lower wishbone, raise the jack until the weight of the suspension is supported.

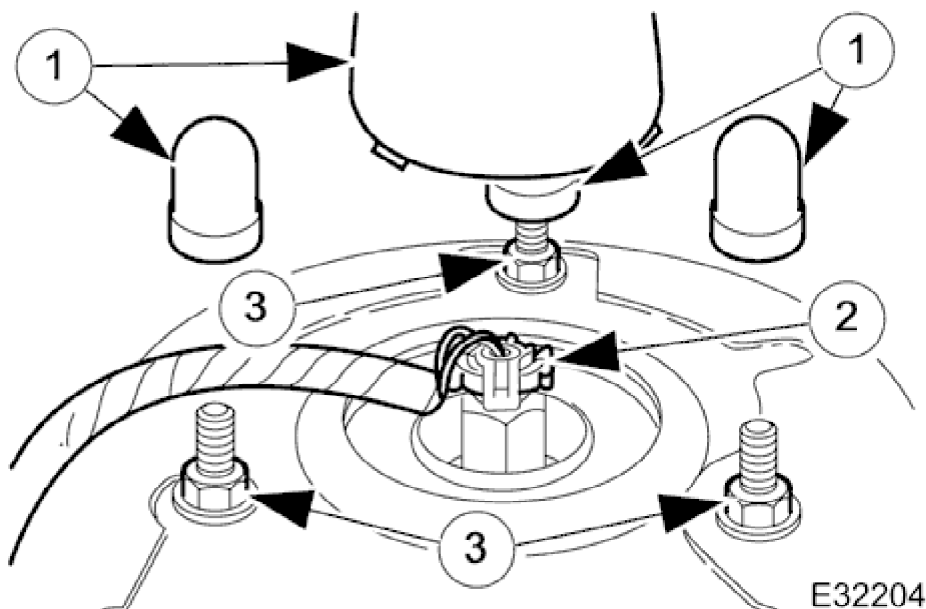

- Remove shock absorber upper-mounting nuts.
 - Remove covers.
 - Vehicles fitted with adaptive damping: disconnect connector.
 - Remove nuts.

2004 XK RANGE - Front Suspension - 204-01

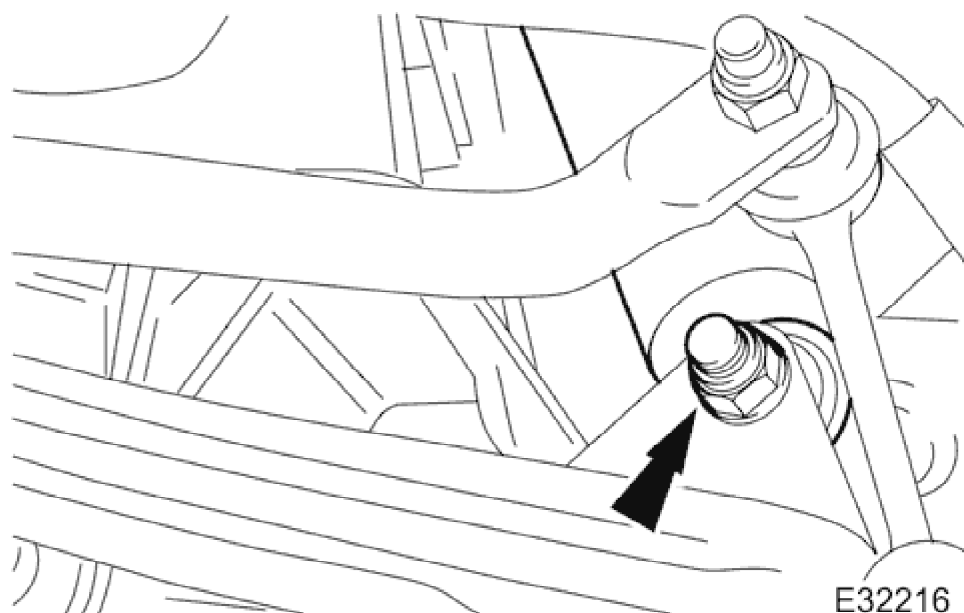

6. Remove nut securing shock absorber to lower mounting, DO NOT remove bolt at this stage.

7. Carefully lower the jack supporting the suspension, while guiding the shock absorber, upper mounting studs through the body. Stop lowering the jack when the studs have passed through the body.

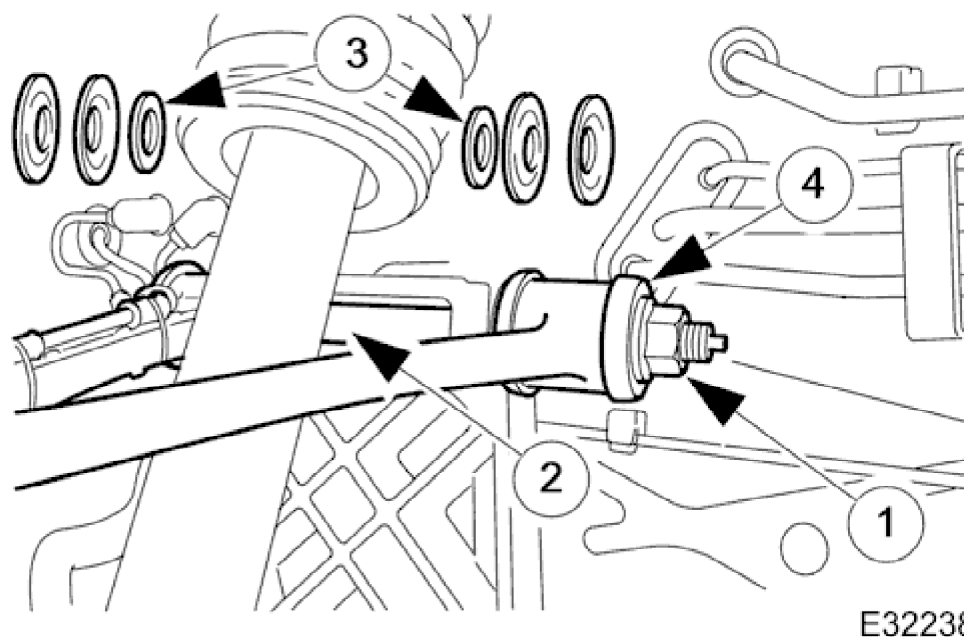

8.  **CAUTION:**
For installation reference, note position of washers and shims before removing fulcrum shaft.

Release upper wishbone from crossbeam, to provide access for the removal of the shock absorber and spring assembly.

1. Remove nut.

2004 XK RANGE - Front Suspension - 204-01

2. Remove fulcrum shaft.
3. Collect washers and shims.
4. Release upper wishbone from crossbeam.

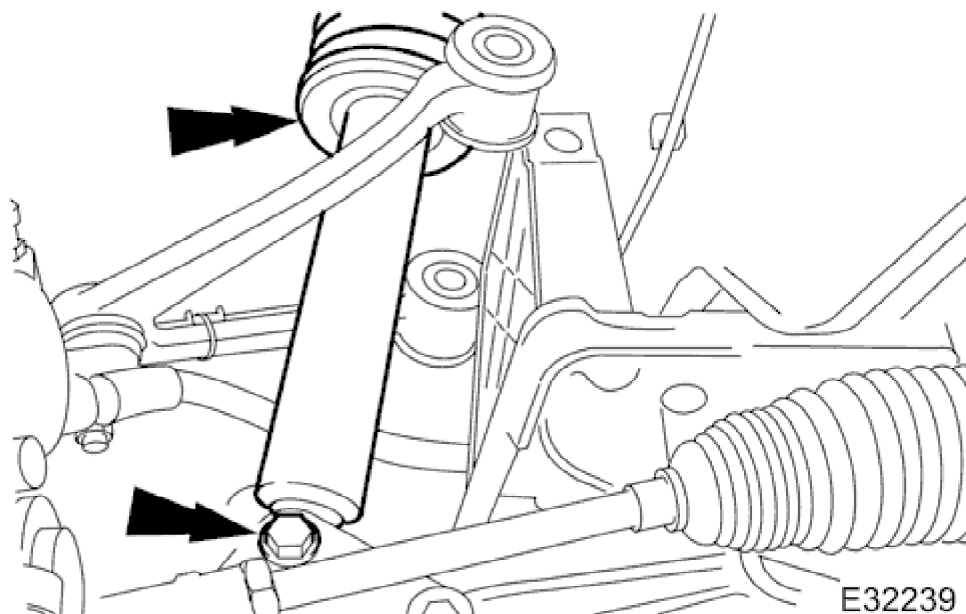

9. **CAUTION:**
Do not stretch the brake hose when removing shock absorber and spring assembly.

With assistance, remove shock absorber and spring assembly.

- Remove bolt from shock absorber lower mounting.
- Remove shock absorber and spring assembly from vehicle.

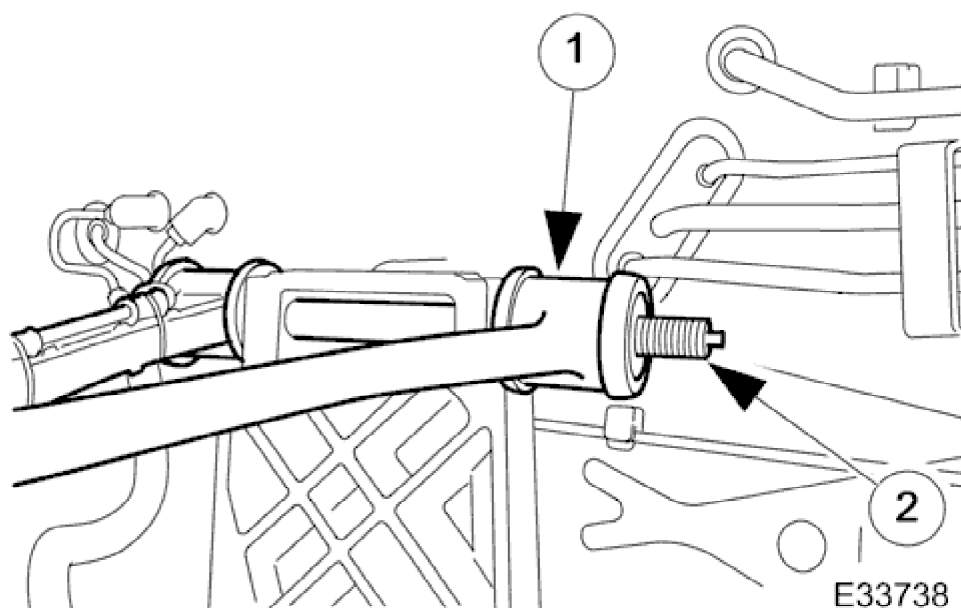

10. Reposition upper wishbone.
1. Align upper wishbone to crossbeam.
 2. Temporarily fit fulcrum shaft.

11. Clean relevant parts.

Installation

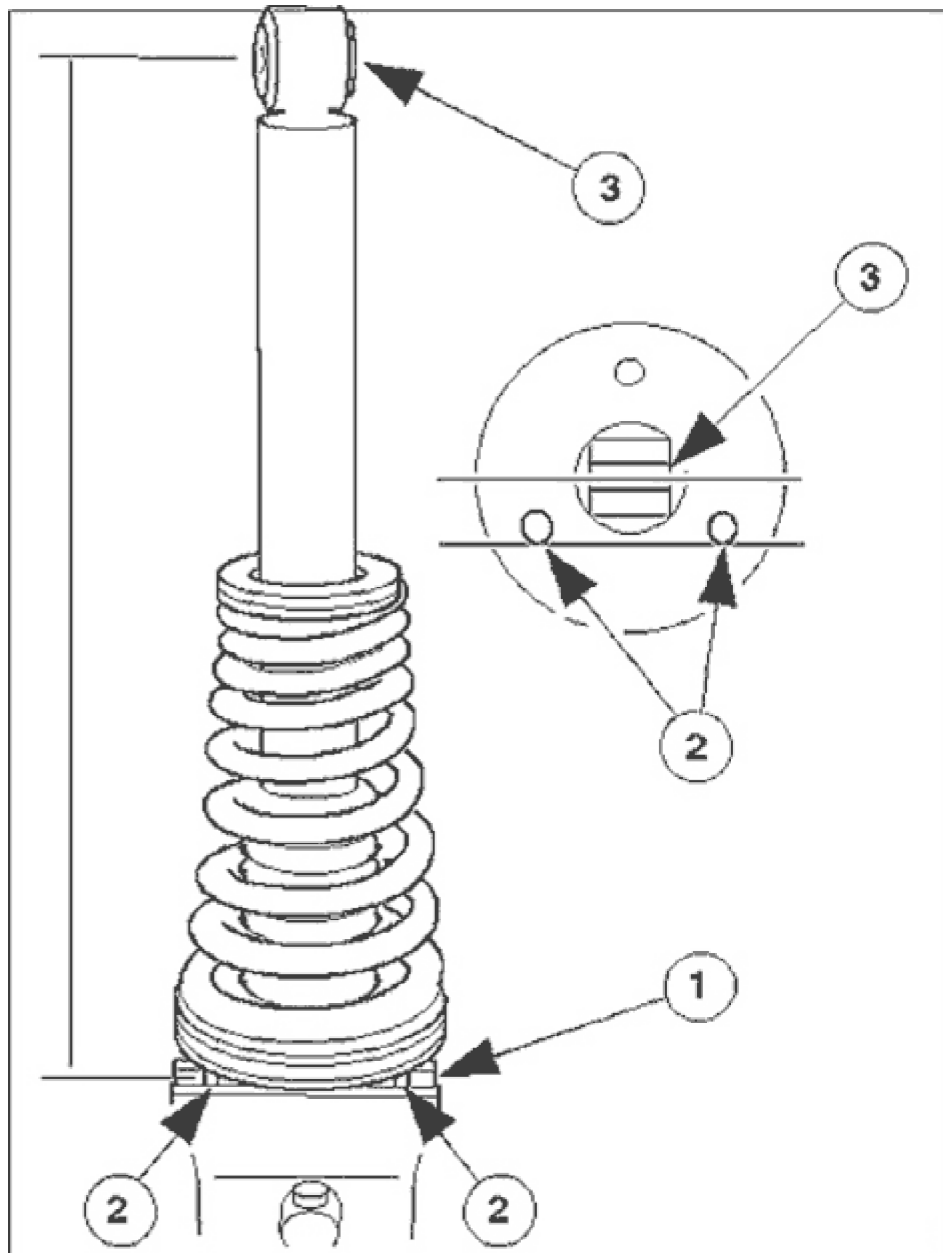

E32247

1. Final alignment of shock absorber with upper mounting studs.
 1. Fit jaw protectors to vice.
 2. Secure assembly in the vice by clamping across two of the upper mounting studs.
 3. Align the lower bush bore so that it is parallel with two of the upper mounting studs.
- Remove assembly from vice.

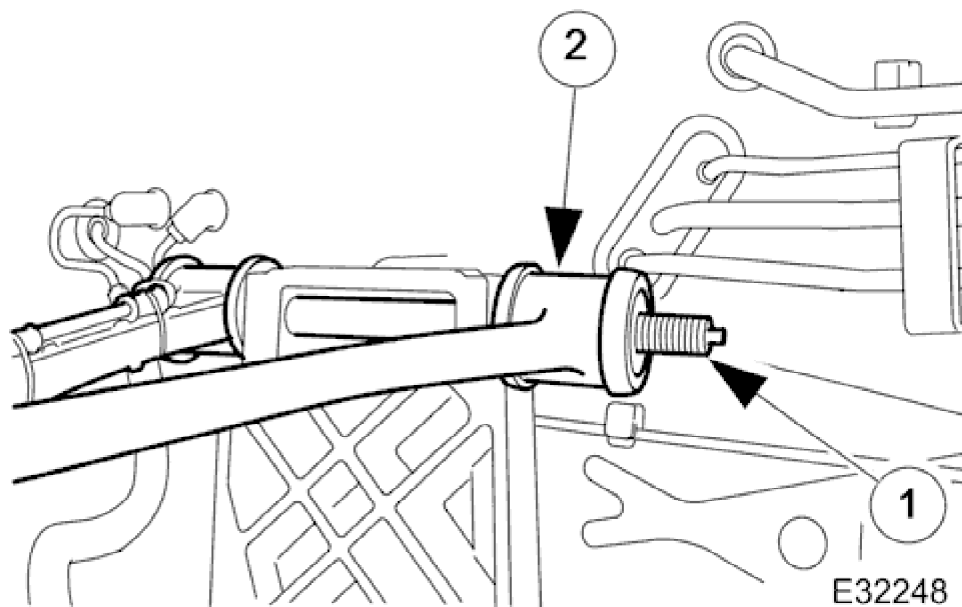

2. Release upper wishbone to provide access for the fitting of the shock absorber and spring assembly.
- 1. Remove fulcrum shaft.
 - 2. Release upper wishbone.

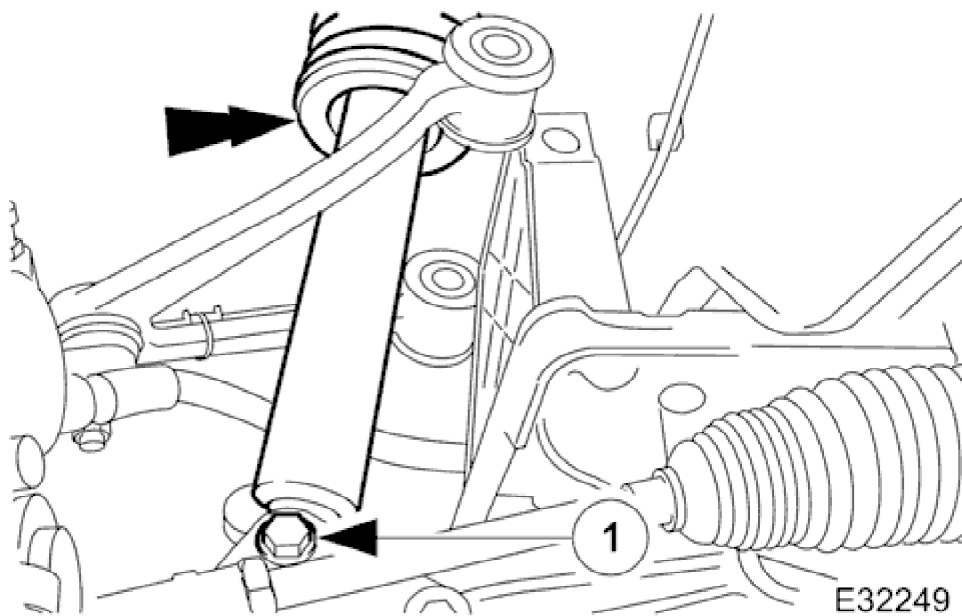

3.  **CAUTION:**
Do not stretch brake-hose when fitting shock absorber and spring assembly.

With assistance, fit shock absorber and spring assembly.

- Position shock absorber to lower mounting.
 - 1. Fit bolt to lower mounting, DO NOT fit nut at this stage.

2004 XK RANGE - Front Suspension - 204-01

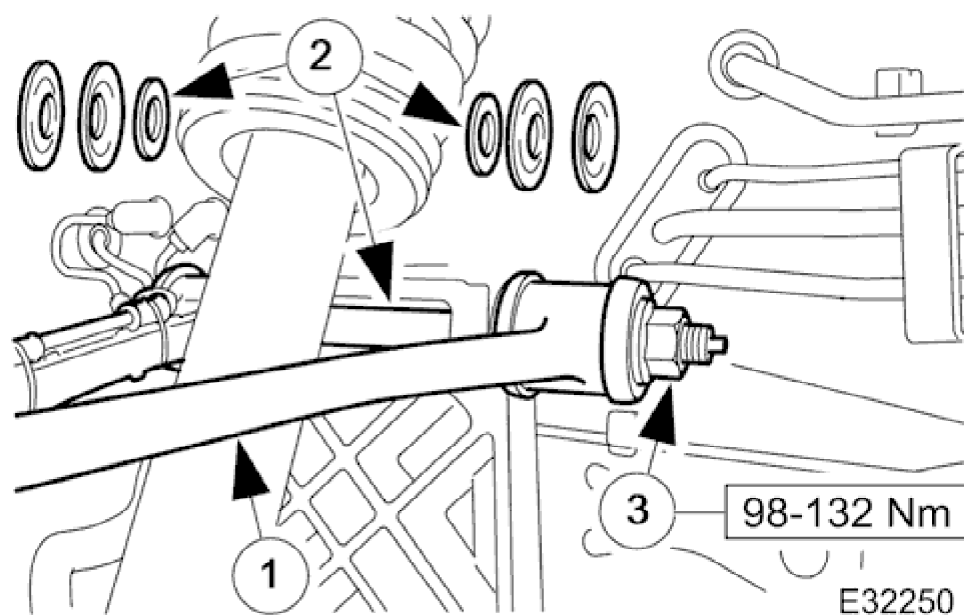

4. Fit upper wishbone.

1. Position wishbone to crossbeam.
2. Fit fulcrum shaft; washers and shims in the positions noted in removal.
3. Fit and tighten nut.

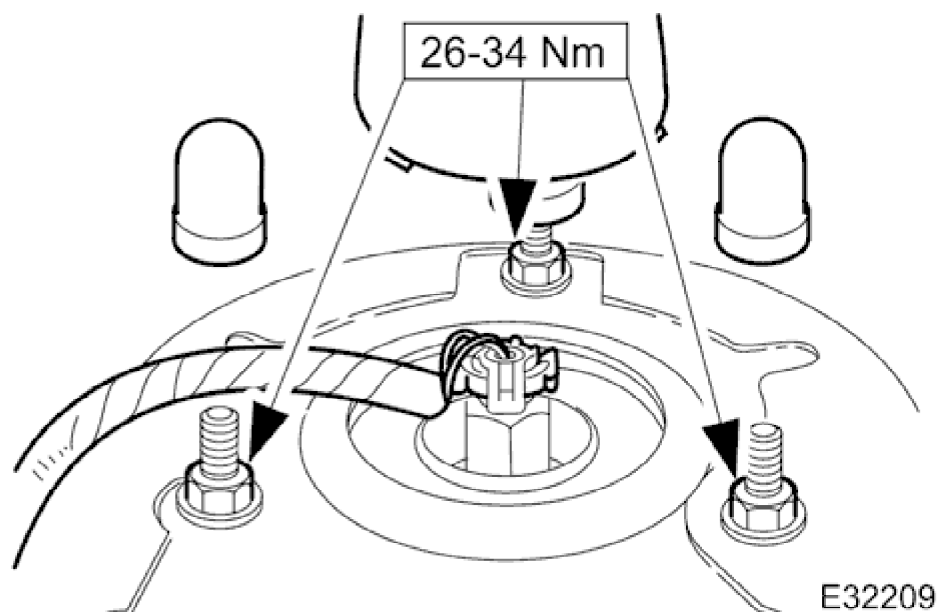

5. CAUTION:

Make sure the adaptive damping electrical connector is correctly aligned. Failure to follow these instructions may cause damage to the electrical connector.

Fit shock absorber and spring assembly upper-mounting to body.

- Raise suspension carefully on jack, and guide upper mounting studs into body stud-holes.
- Fit and tighten nuts.
- Vehicles fitted with adaptive damping: connect connector.

2004 XK RANGE - Front Suspension - 204-01

- Fit covers.

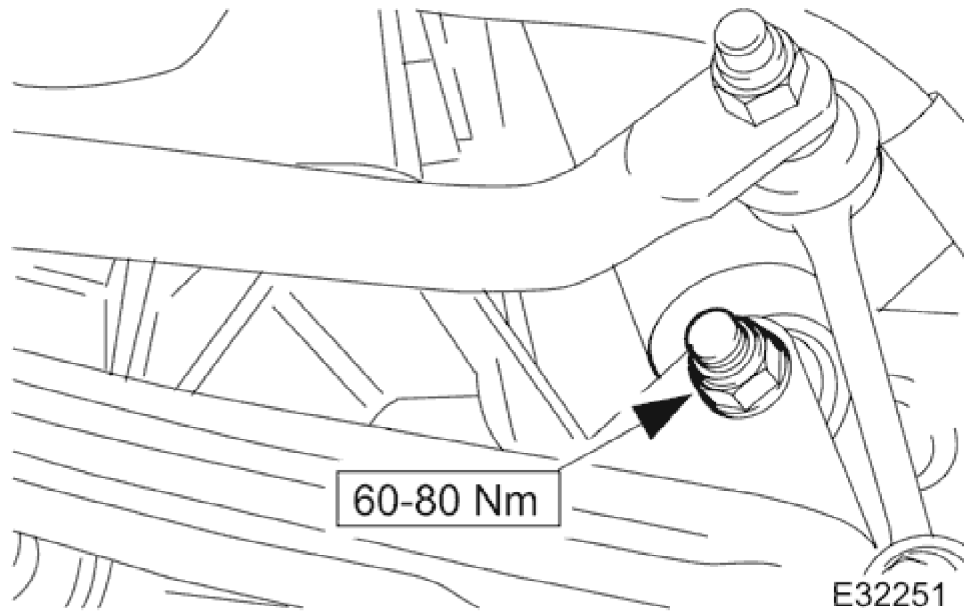

6. Fit nut to shock absorber lower mounting.
 - Fit and tighten nut.

7. Lower and remove jack supporting suspension.

8. Fit wheel. Refer to section <<204-04>>.

9. Remove stands and lower vehicle.

10. Remove paintwork protection covers.