

Shock Absorber and Spring Assembly 60.30.21

Special Service tools

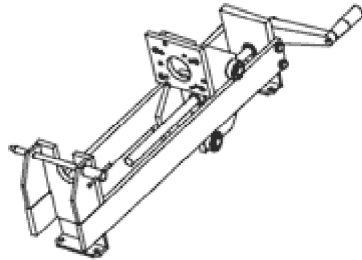

204-476

Compressor, Coil Spring
204-476

Disassembly

1.  **CAUTION:**
Replacement of nuts and bolts: Various thread-locking devices are used on nuts and bolts throughout the vehicle. These devices restrict the number of times a nut or bolt can be used. <<100-00>>

Remove the front shock absorber and spring assembly.

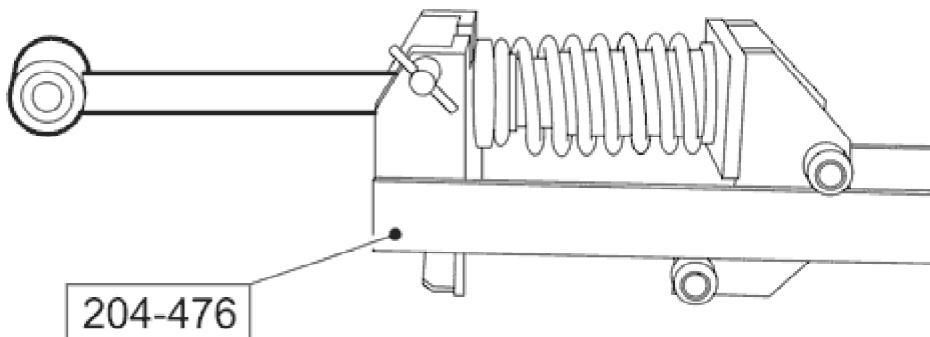

E31044

2.  **WARNING:**
MAKE SURE THE SHOCK ABSORBER IS SECURED BY FULLY INSERTING THE LOCKING PIN IN TO THE SPECIAL TOOL. FAILURE TO FOLLOW THESE INSTRUCTIONS MAY RESULT IN PERSONAL INJURY.

Install the shock absorber and spring assembly to the special tool as shown.

2004 XK RANGE - Front Suspension - 204-01

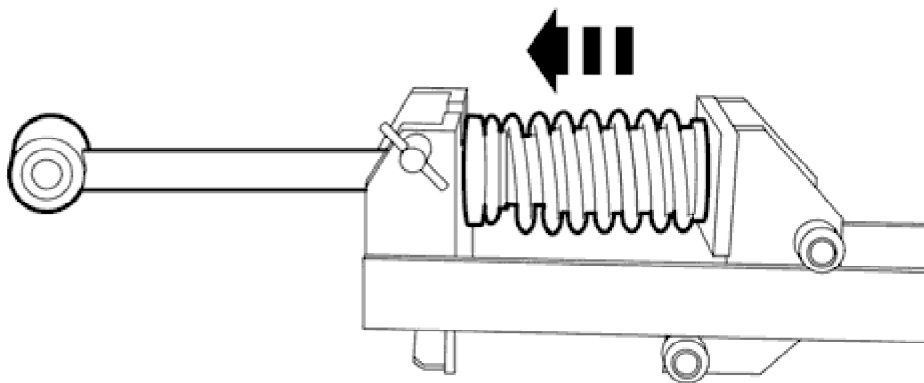

E31046



WARNING:

AS THE SPRING IS UNDER EXTREME TENSION CARE MUST BE TAKEN AT ALL TIMES. FAILURE TO FOLLOW THESE INSTRUCTIONS MAY RESULT IN PERSONAL INJURY.

Clamp the road spring.

- Rotate the handle until spring pressure is released.

NOTATION GIF

ENTITY SYSTEM "..\GRAPHIC\E43415.GIF"

4. Remove the shock absorber retaining nut.

- Remove and discard the retaining nut.

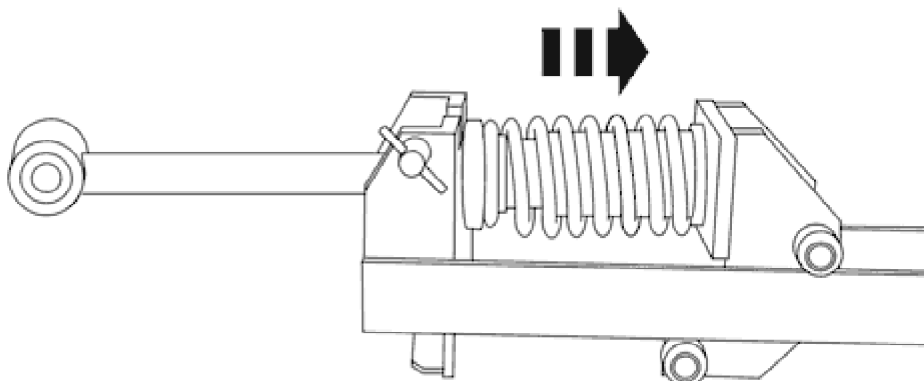

E31045

5. Release the road spring.

2004 XK RANGE - Front Suspension - 204-01

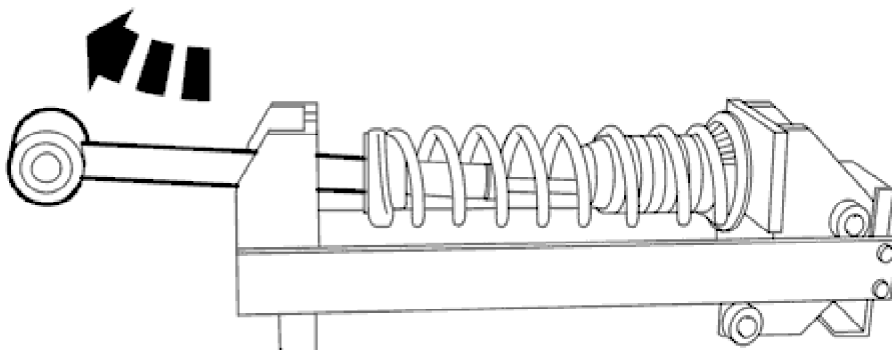

E31047

6. Remove the shock absorber.

NOTATION GIF
ENTITY SYSTEM "..\GRAPHIC\E33739.GIF"

7. Remove the gaiter assembly from the upper mounting.
 1. Disengage the gaiter from the upper mounting.
 2. Remove the spring assister from the gaiter.

8. Clean the relevant parts.

Assembly

NOTATION GIF
ENTITY SYSTEM "..\GRAPHIC\E32295.GIF"

1. **NOTE:**
To ease fitting apply a suitable lubricant to the spring assister and gaiter.

NOTE:
Make sure the gaiter assembly is seated securely and squarely into the upper mounting.

Assemble the upper mounting.

1. Insert the spring assister fully into the gaiter.
2. Insert the gaiter into upper mounting location.

2004 XK RANGE - Front Suspension - 204-01

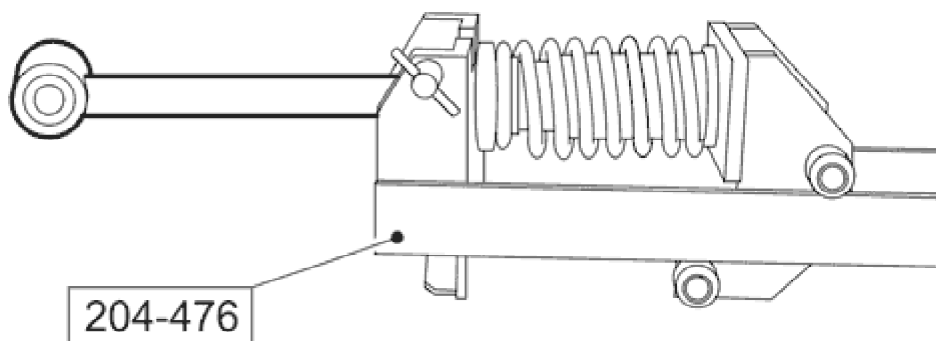

E31044

2.  **CAUTION:**
Make sure circlip on the shock absorber abuts with the lower spring pan.

-  **CAUTION:**
Make sure the spring ends butt correctly against the spring seats.

Install the shock absorber and spring assembly to the special tool.

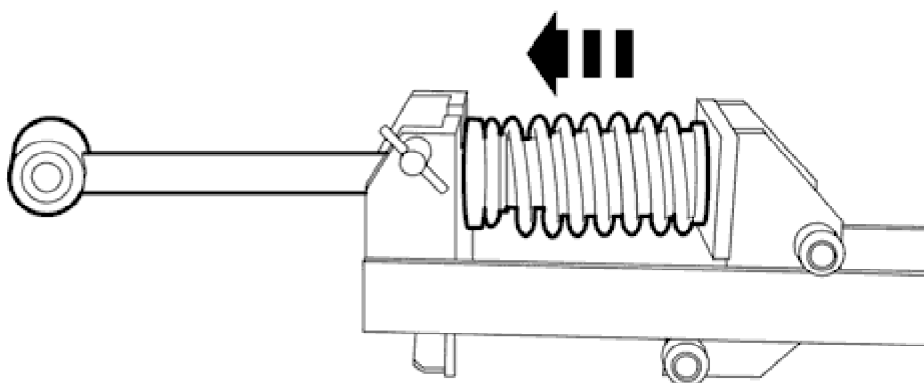

E31046

3.  **WARNING:**
AS THE SPRING IS UNDER EXTREME TENSION CARE MUST BE TAKEN AT ALL TIMES. FAILURE TO FOLLOW THESE INSTRUCTIONS MAY RESULT IN PERSONAL INJURY.

Clamp the road spring.

NOTATION GIF
ENTITY_SYSTEM "..\GRAPHIC\E43415.GIF"

4. Vehicles without adaptive damping.
- Install a new retaining nut.
 - Tighten to 40 Nm.

2004 XK RANGE - Front Suspension - 204-01

NOTATION GIF
ENTITY SYSTEM "..\GRAPHIC\E43415.GIF"

5. Vehicles with adaptive damping.

- Install a new retaining nut.
- Tighten to 18 Nm.

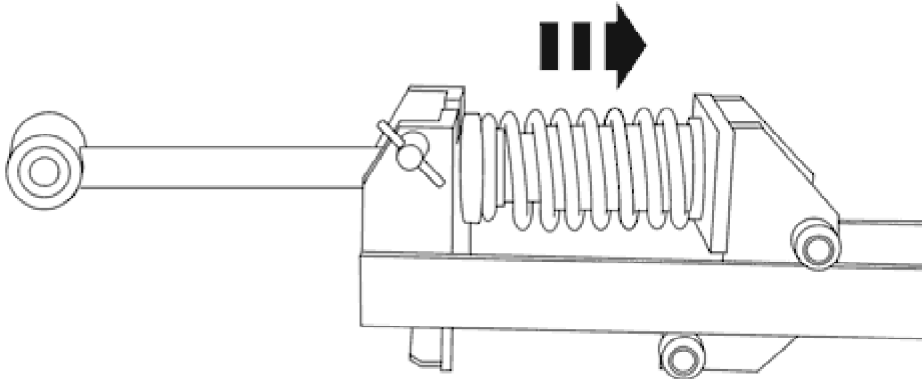

E31045

6. Release the road spring.

7. Remove the shock absorber and spring assembly from the special tool.

8. Install the front shock absorber and spring assembly.