

## Radiator 26.40.01

### Removal

1. Open the driver's door, or both doors if necessary, to allow the side windows to drop. Ensure that the doors remain open until after the battery has been disconnected.
2. Open the engine compartment and fit paintwork protection sheets.

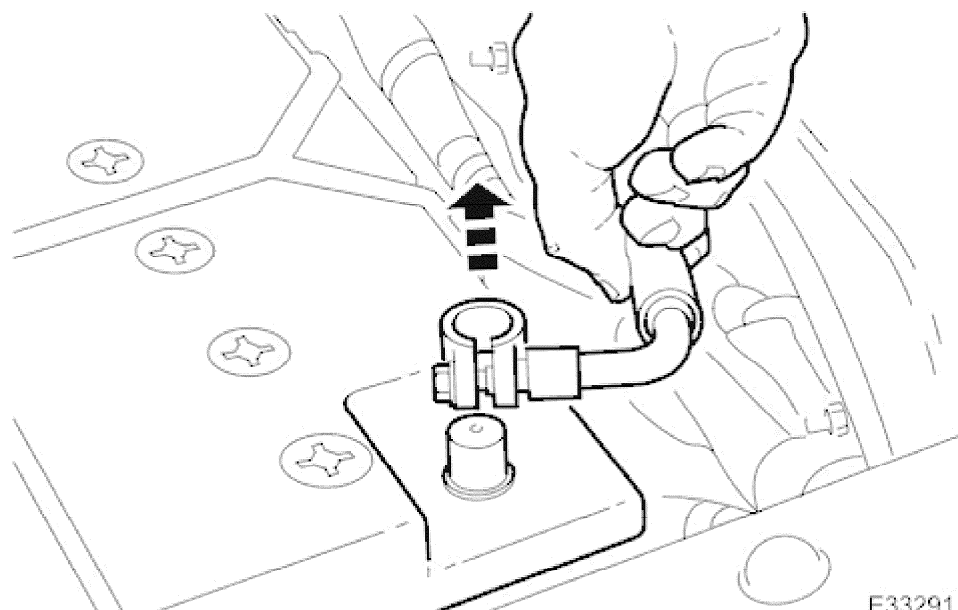

3. Disconnect the battery ground cable.
  - Remove the battery cover.
4. Drain the coolant from the radiator.
5. Depressurise the climate control system. Refer to Operation <<82.30.30>>. Observe all safety warnings and precautions stated in that section.
6. Remove the air cleaner assembly; refer to Operation <<19.10.05>>.

## 1997 XK RANGE - Engine Cooling - 303-03

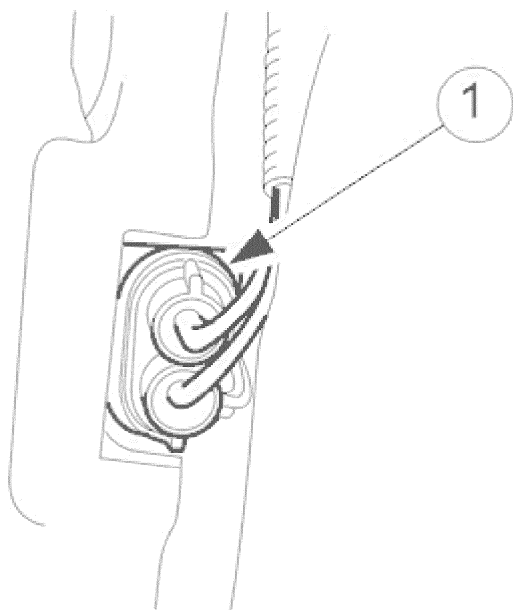

E35305

7. Disconnect harness multiplug from the cooling fan (working from under the vehicle).
1. Disconnect the multiplug from the high speed fan and reposition the harness from the retaining clip.

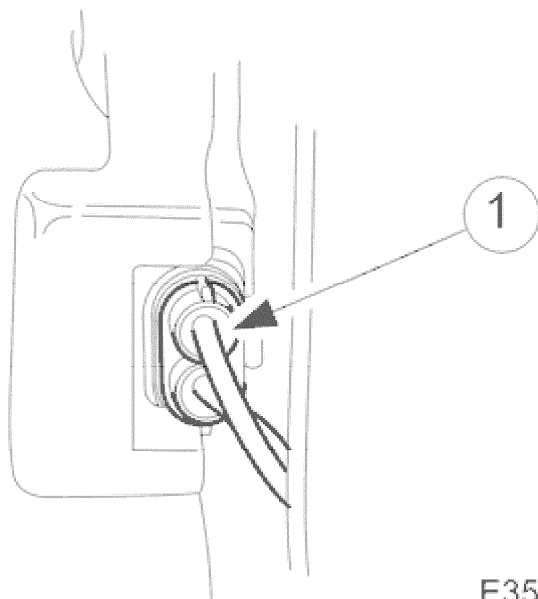

E35319

8. Disconnect harness multiplug from the cooling fan (working from under the vehicle).
1. Disconnect the multiplug from the low speed fan and reposition the harness from the retaining clip.

## 1997 XK RANGE - Engine Cooling - 303-03

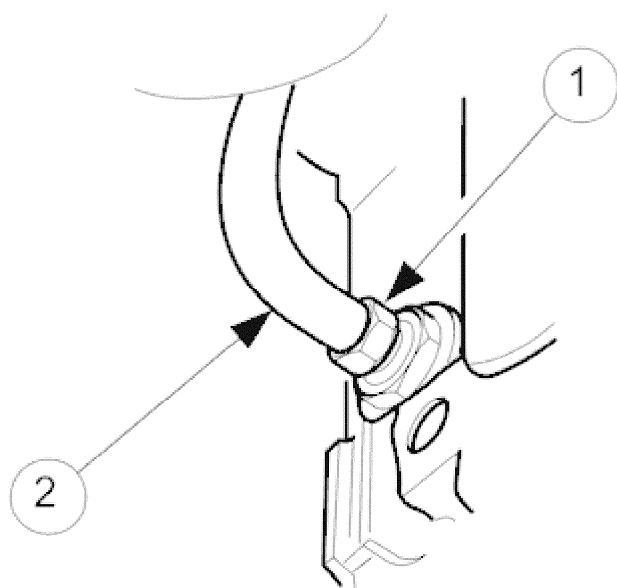

E35306

9. Disconnect the transmission oil cooler lower pipe.
  1. Disconnect and reposition the union nut, lower cooler pipe to radiator. Disconnect the pipe.
  2. Remove and discard the O-ring seal from the pipe and install blanking plugs to the pipe and to the union on the radiator.
  3. Reposition the climate control pipe from the clip on the fan cowl.

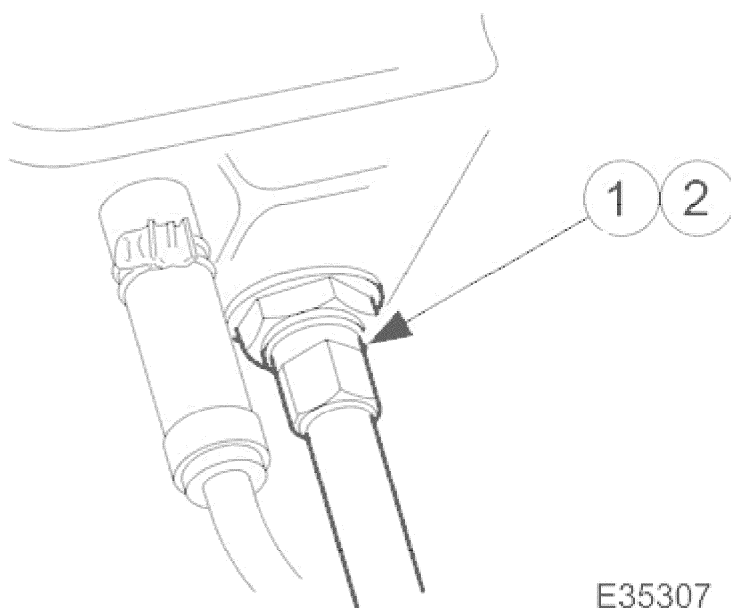

E35307

10. From above the vehicle, disconnect the transmission oil cooler upper pipe.
  1. Disconnect and reposition the union nut, upper cooler pipe to radiator. Disconnect the pipe.
  2. Remove and discard the O-ring seal from the pipe and install blanking plugs to the pipe and to the union on the radiator.

## 1997 XK RANGE - Engine Cooling - 303-03

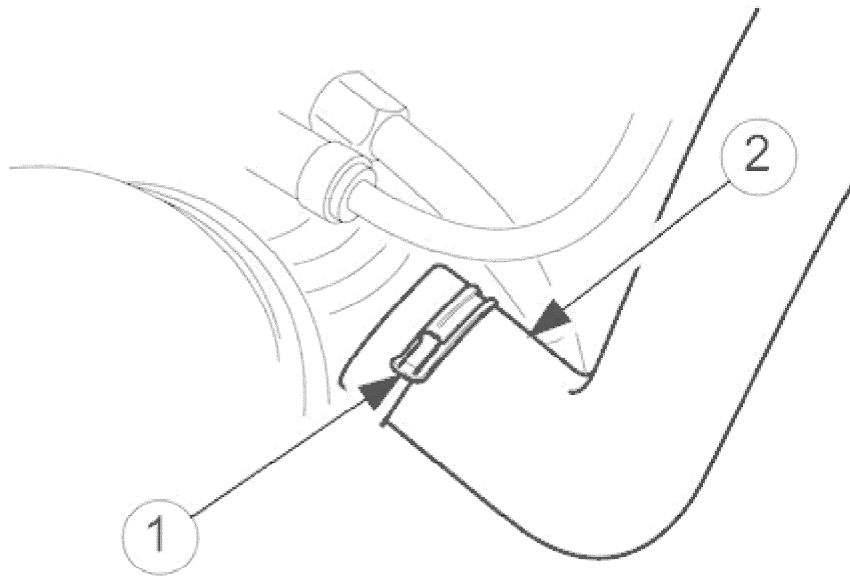

E35308

11. Disconnect the radiator bottom hose.
  1. Slacken the hose retaining clip and reposition the clip along the hose.
  2. Disconnect the hose from the radiator.

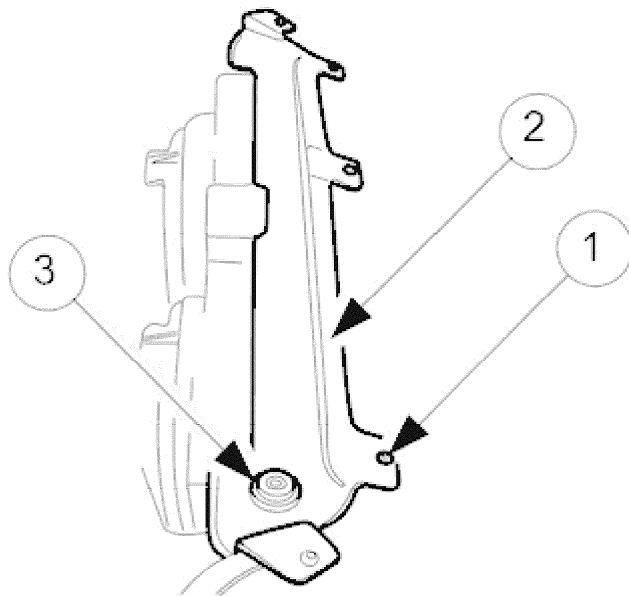

E35309

12. Remove the radiator top retaining panel.
  1. Remove the five bolts which secure the panel.
  2. Remove the panel.
  3. Remove the radiator top mounting rubbers.

## 1997 XK RANGE - Engine Cooling - 303-03

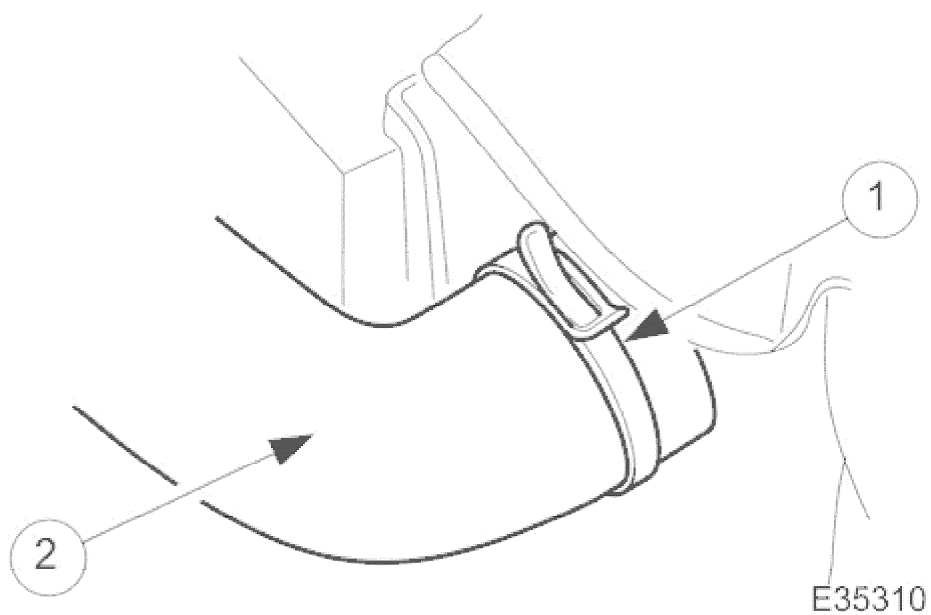

13. Disconnect the radiator top hose.
1. Slacken the hose retaining clip and reposition the clip along the hose.
  2. Disconnect the hose from the radiator.

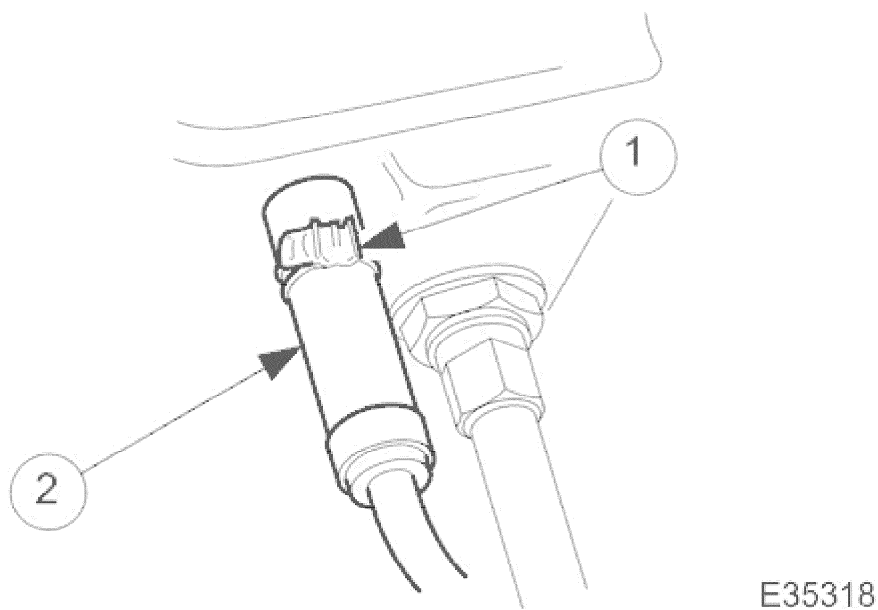

14. Disconnect the radiator breather hose.
1. Slacken the hose (radiator to expansion tank) retaining clip and reposition the clip along the hose.
  2. Disconnect the hose from the radiator.

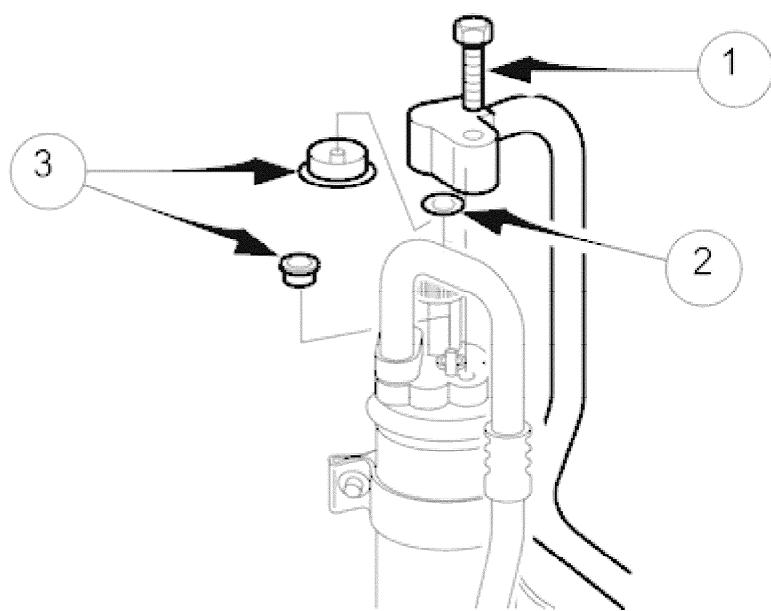

15. Disconnect the pipe from the climate control receiver / drier.
1. Remove the bolt which secures the pipe to the receiver / drier and disconnect the pipe.
  2. Remove and discard the O-ring.
  3. Install blanking plugs to the pipe and the receiver drier.

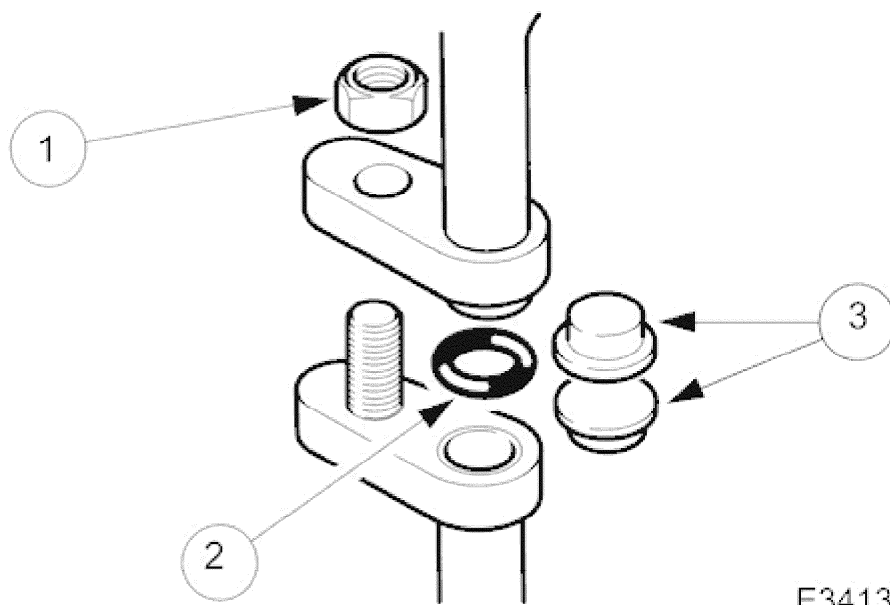

16. Disconnect the pipe from the climate control condenser joint (condenser to compressor).
1. Remove the nut which secures the pipe to the condenser and disconnect the pipe.
  2. Remove and discard the O-ring.
  3. Install blanking plugs to the pipe and the condenser.

## 1997 XK RANGE - Engine Cooling - 303-03

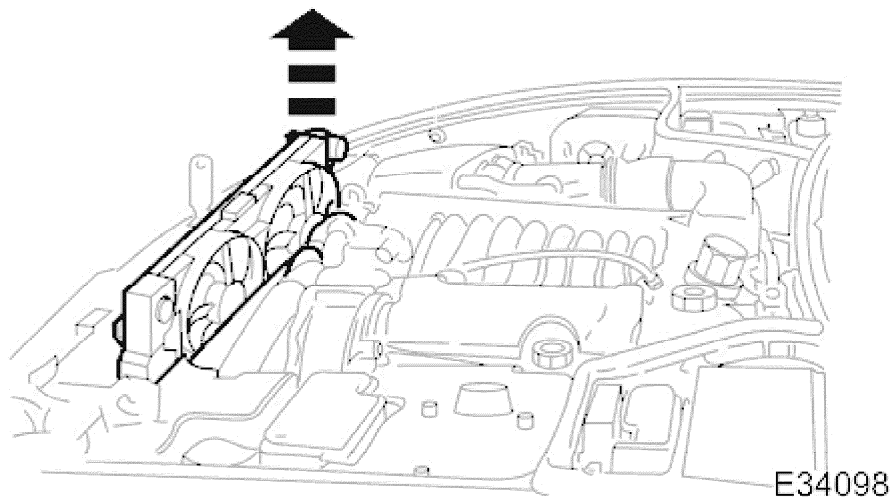

17. Remove the radiator.
  1. With assistance, remove the radiator assembly.
    - Clean coolant spillage from the radiator lower carrier panel.

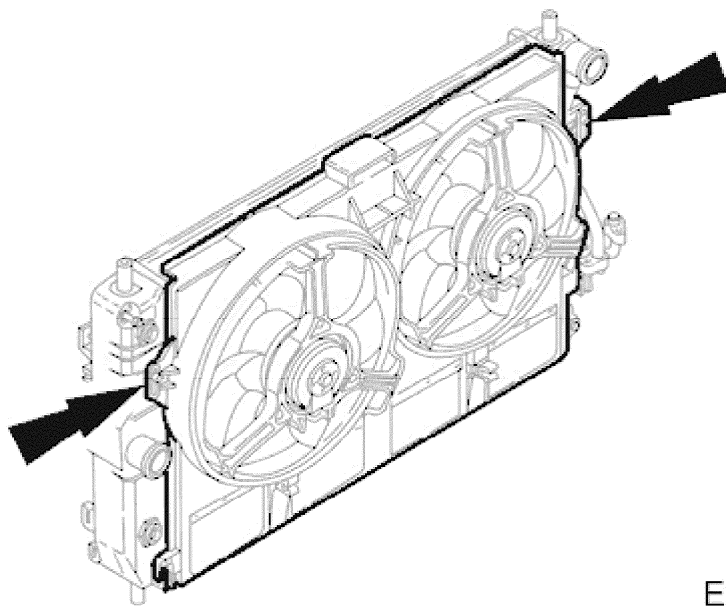

18. Remove the fan cowl from the radiator assembly.
  1. Remove the two nuts which secure the cowl to the radiator.
  2. Remove the cowl from the radiator.

## 1997 XK RANGE - Engine Cooling - 303-03

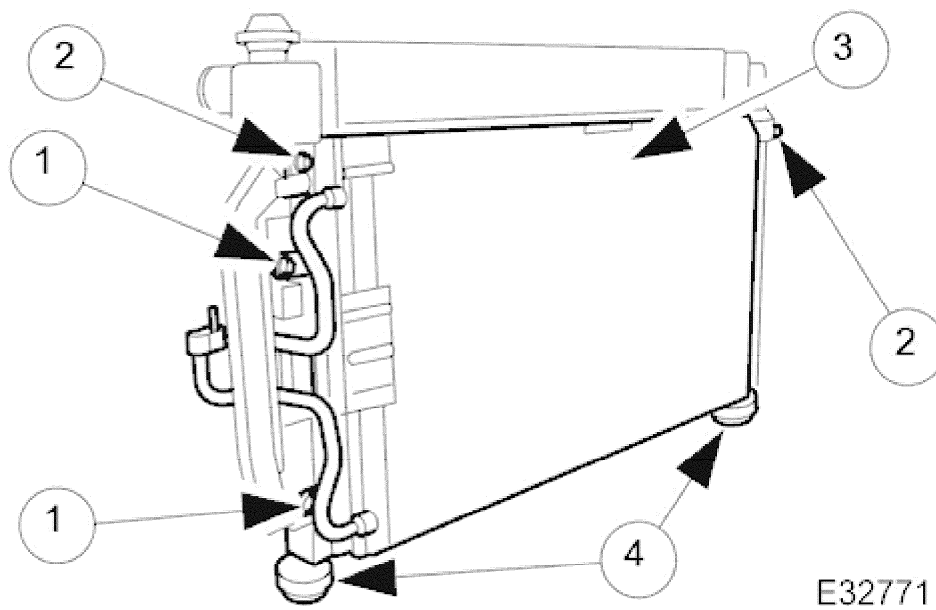

19. Remove the condenser from the radiator.

1. Remove the two bolts which secure the condenser pipe protective bracket and remove the bracket.
2. Remove the two bolts which secure the condenser to the radiator.
3. Remove the condenser.
4. Remove the radiator lower mounting rubbers.

### Installation

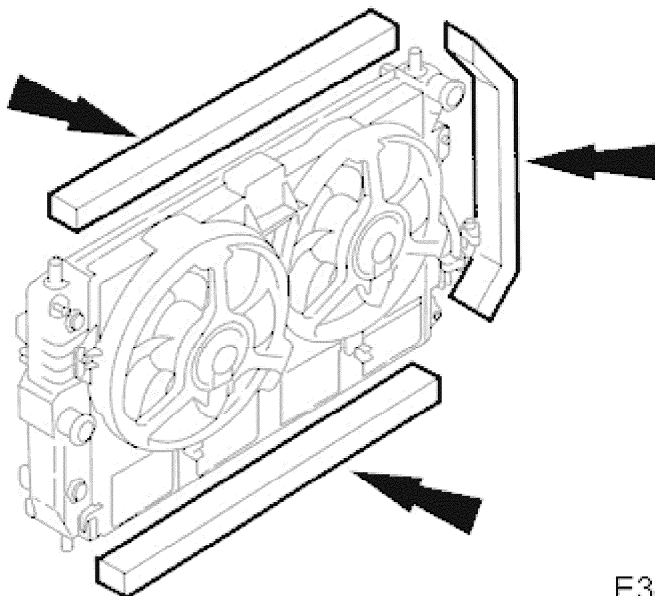

1. Install new foam sealing strips to the radiator top, bottom and left side.



## 1997 XK RANGE - Engine Cooling - 303-03

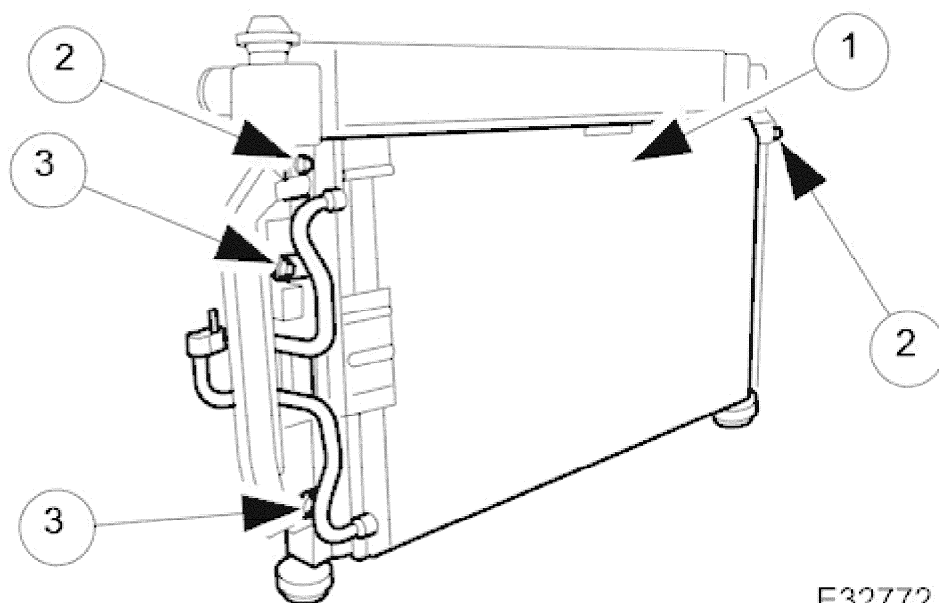

E32772

2. Install the condenser to the radiator.
  1. Position the condenser.
  2. Install the two bolts which secure the condenser to the radiator.
  3. Position the condenser pipe protective bracket and install the two securing bolts.

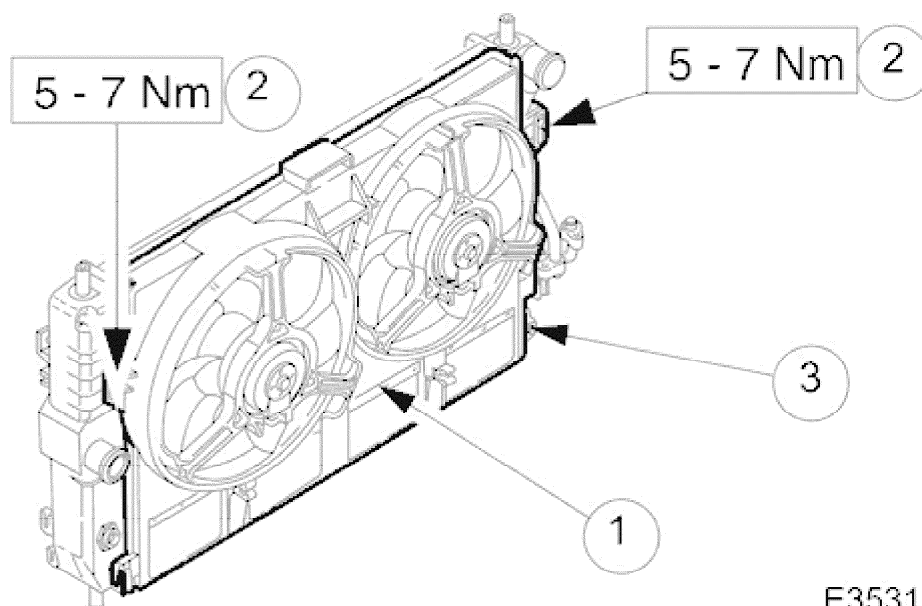

E35312

3. Install the fan cowl to the radiator assembly.
  1. Position the cowl to the radiator.
  2. Install the two nuts which secure the cowl to the radiator. Tighten to 5-7 Nm.
  3. Install the radiator lower mounting rubbers.

4. With assistance, reposition the radiator to the vehicle. Check that the lower mounting rubbers are located correctly.

## 1997 XK RANGE - Engine Cooling - 303-03

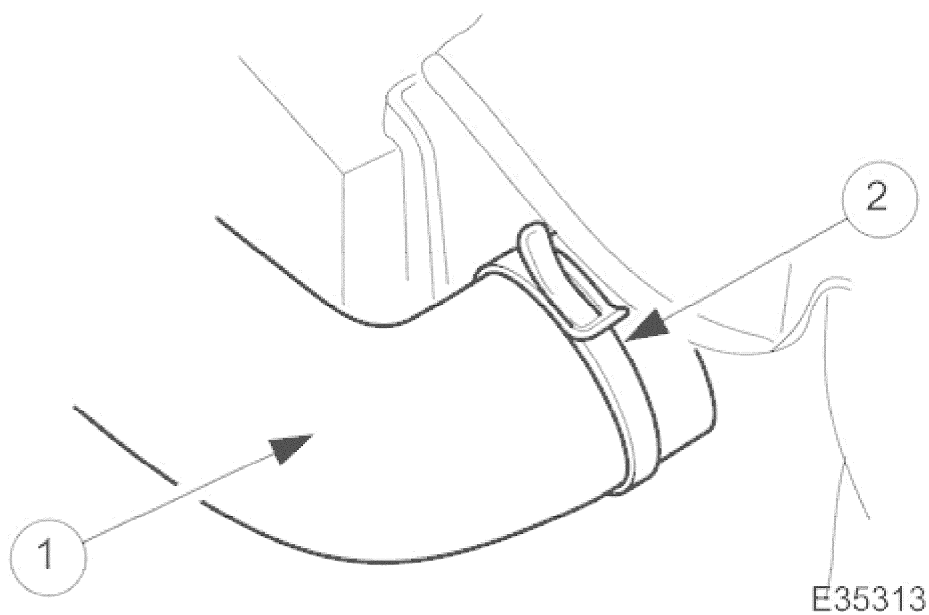

5. Connect the radiator coolant top hose.
1. Reposition and connect the top hose to the radiator.
  2. Install and tighten the hose clip.

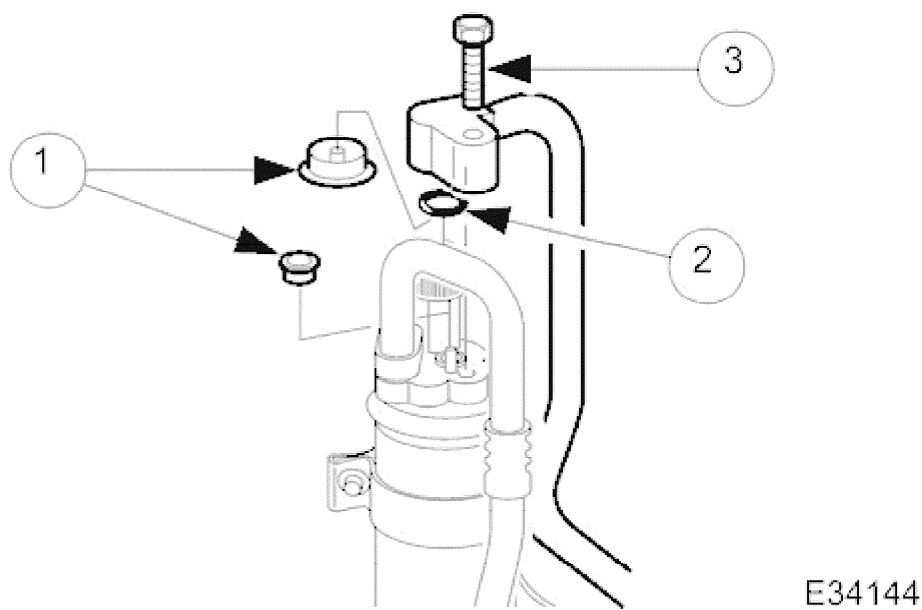

6. Connect the pipe to the receiver / drier.
1. Remove the blanking plugs from the pipe and from the receiver / drier.
  2. Install a new O-ring seal to the pipe.
  3. Reconnect the pipe to the receiver / drier and install the securing bolt. Tighten to 7-10 Nm.

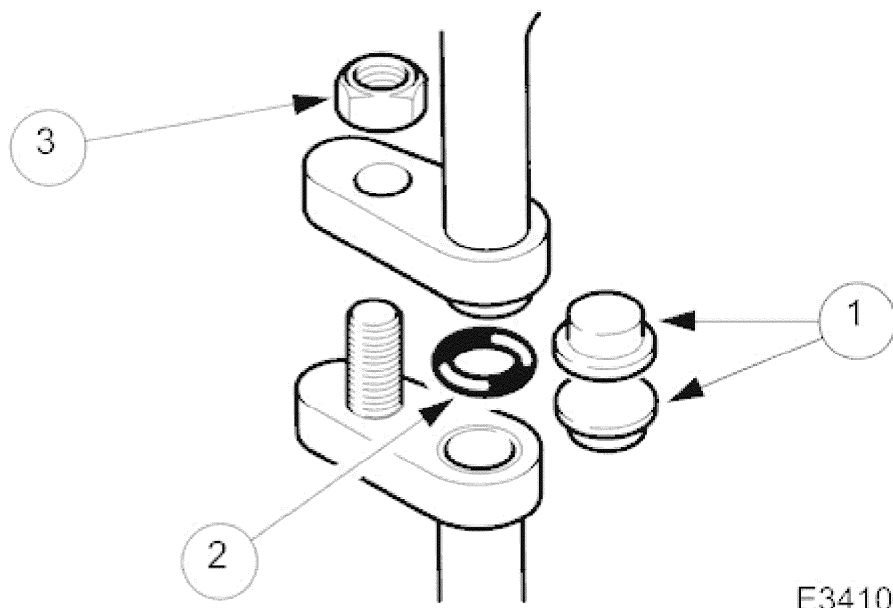

7. Connect the pipe to the compressor.
1. Remove the blanking plugs from the pipe.
  2. Install a new O-ring seal to the pipe.
  3. Reconnect the pipe to the compressor / condenser joint and install the securing nut. Tighten to 7-10 Nm.

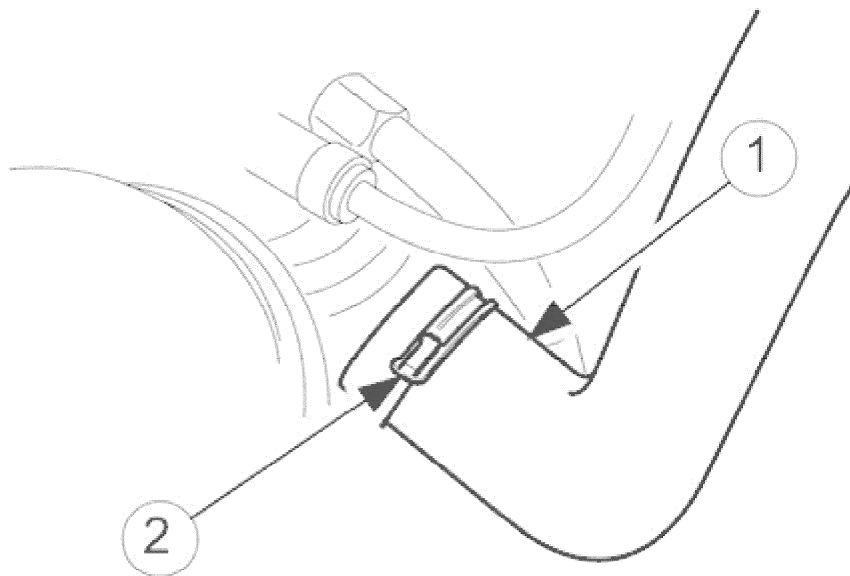

8. Connect the radiator coolant bottom hose.
1. Reposition and connect the bottom hose to the radiator.
  2. Install and tighten the hose clip.

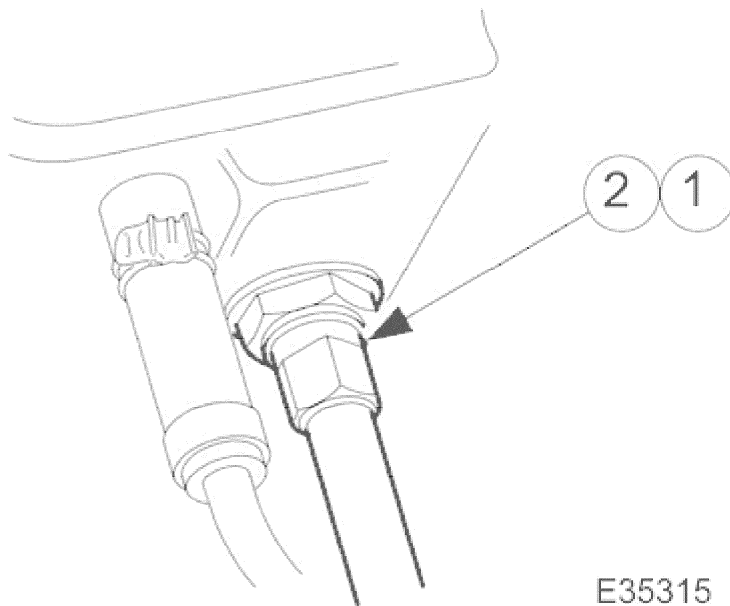

9. Connect the transmission oil cooler upper pipe.

1. Remove the blanking plugs and install a new O-ring seal to the pipe. Reposition the pipe and the union nut to the radiator.
2. Connect and tighten the union nut.

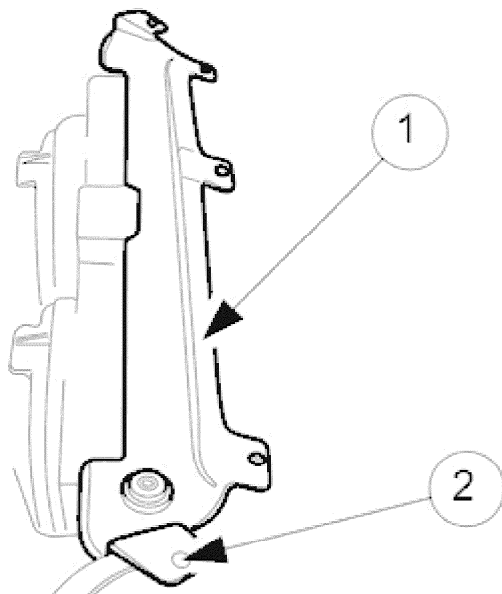

10. Install the radiator top securing panel.

1. Position and align the top securing panel.
2. Install the five securing bolts to the panel. Tighten to 7-10 Nm.

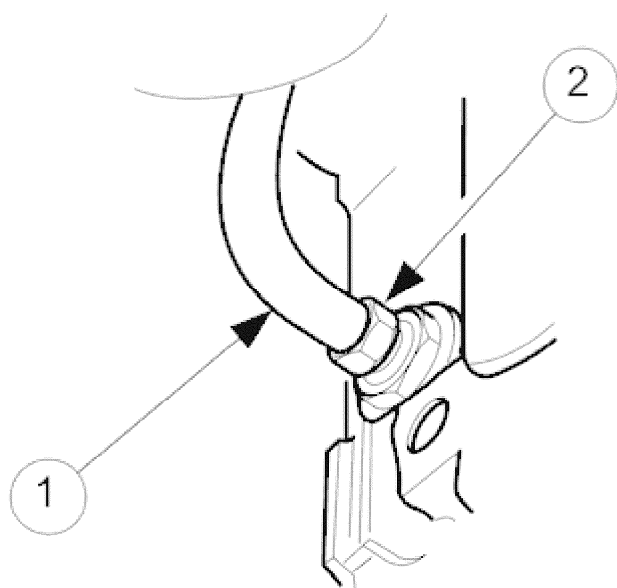

E35317

11. From below the vehicle, connect the transmission lower cooler pipe to the radiator.
  1. Remove the blanking plugs and install a new O-ring seal to the cooler pipe.
  2. Reposition the pipe and the union nut to the radiator.
  3. Connect and tighten the union nut.
  4. Reposition and install the climate control pipe to the clips on the fan cowl.

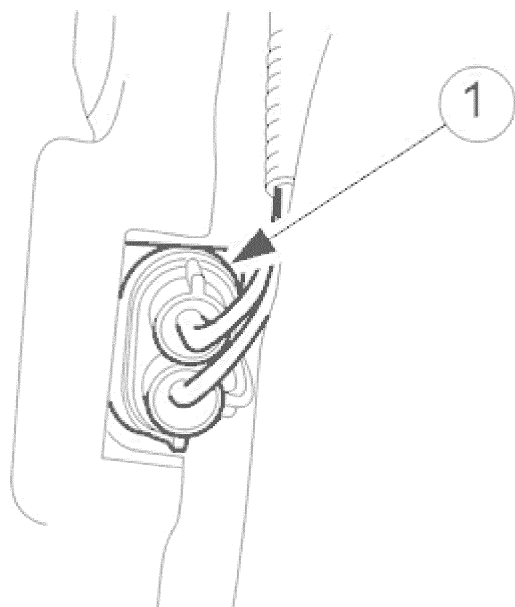

E35305

12. Connect the harness multiplug to the cooling fans.
  1. Connect the multiplug to the high speed fan and reposition the harness into the retaining clip.

## 1997 XK RANGE - Engine Cooling - 303-03

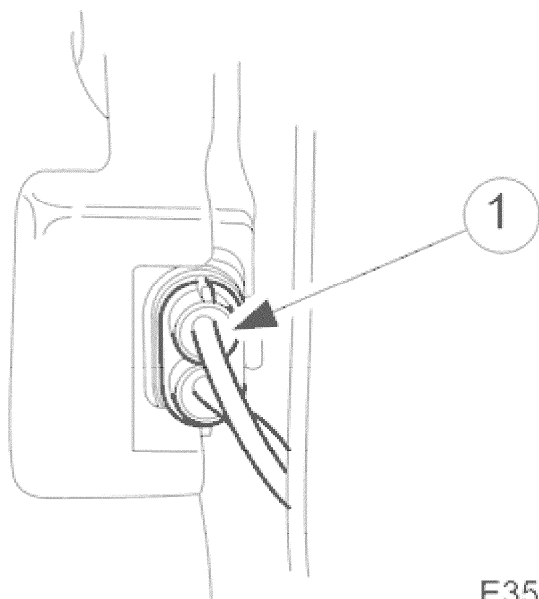

E35319

13. Connect the harness multiplug to the cooling fans.
  1. Connect the multiplug to the low speed fan and reposition the harness into the retaining clip.
14. Check the level and replenish the transmission fluid as necessary.
15. From above the vehicle, install the air cleaner assembly; refer to Operation <<19.10.05>>.
16. Refill the cooling system. Refer to the Refill Procedure 26.10.01.
17. Repressurise the climate control system. Refer to Operation <<82.30.30>>. Observe all safety warnings and precautions stated in that section.
18. Connect the battery and install the battery cover.
  - Reset the side glass memory. Refer to the Battery Reconnection Procedure <<86.15.15>>.